

REPAIR MANUAL



250

255

Publication No. 49903
April, 2005

THOMAS

THOMAS EQUIPMENT LIABILITY WARRANTY

THE WARRANTY IS THE ONLY OBLIGATION OF THOMAS OR A THOMAS DEALER TO THE PURCHASER OR ANYONE ELSE CONCERNING A PRODUCT, ITS SERVICE, ITS USE OR PERFORMANCE OR ITS LOSS OF USE OR FAILURE TO PERFORM. NEITHER THOMAS NOR A THOMAS DEALER HAVE MADE AND NEITHER WILL MAKE ANY OTHER EXPRESSED OR IMPLIED REPRESENTATION, WARRANTY OR AGREEMENT CONCERNING A PRODUCT. NEITHER THOMAS NOR A THOMAS DEALER HAVE MADE OR WILL MAKE ANY REPRESENTATION, WARRANTY OR AGREEMENT CONCERNING A PRODUCTS MERCHANTABILITY OR OTHER QUALITY, ITS SUITABILITY FOR PURCHASER'S PURPOSE (EVEN IF A PURCHASER HAS INFORMED THOMAS OR A THOMAS DEALER OF THAT PURPOSE), ITS DURABILITY, PERFORMANCE OR OTHER CONDITION.

EVEN IF THOMAS OR A THOMAS DEALER WAS ADVISED OF THE POSSIBILITY OF SUCH LOSS, NEITHER THOMAS NOR A THOMAS DEALER WILL BE LIABLE TO PURCHASER OR ANYONE ELSE FOR ANY INDIRECT, INCIDENTAL CONSEQUENTIAL, PUNITIVE, ECONOMIC, COMMERCIAL, OR SPECIAL LOSS WHICH IS IN ANY WAY ASSOCIATED WITH A PRODUCT. THIS INCLUDES ANY LOSS OF USE OR NON-PERFORMANCE OF A PRODUCT, ANY REPLACEMENT RENTAL OR ACQUISITION COST, ANY LOSS OF REVENUE OR PROFITS, ANY FAILURE TO REALIZE EXPECTED SAVINGS, ANY INTEREST COSTS, ANY IMPAIRMENT OF OTHER GOODS, ANY INCONVENIENCE OR ANY LIABILITY OF PURCHASER TO ANY OTHER PERSON.

PURCHASER MAY NOT ATTEMPT TO ENLARGE ITS RIGHTS UNDER THE WARRANTY BY MAKING A CLAIM FOR INDEMNITY, FOR BREACH OF CONTRACT, FOR BREACH OF COLLATERAL WARRANTY, FOR A TORT (INCLUDING NEGLIGENCE, MISREPRESENTATION OR STRICT LIABILITY) OR BY CLAIMING ANY OTHER CAUSE OF ACTION.

THE WARRANTY IS A CONDITION OF SALE OF THE PRODUCT TO PURCHASER AND WILL THEREFORE APPLY EVEN IF PURCHASER ALLEGES THAT THERE IS A TOTAL FAILURE OF THE PRODUCT.

*N.B. Read and practice your **Thomas** operating and servicing instructions. Failure to do this may void your warranty.*

Publication Number 49903

TABLE OF CONTENTS

Forword

Serial Numbers	5
Safety Precautions	6 ~ 10

Section 1

Hydraulic System

Hydraulic Circuit	1.1
Gear Pump	1.2
Control Valve	1.3
Hydraulic Cylinders	1.4
Oil Filter	1.5
Oil Cooler	1.6
Oil Reservoir	1.7
Trouble Shooting	1.8
Torque Chart	1.9
Conversion Chart	1.10

Section 2

Hydrostatic Drive System

Hydrostatic Drive Circuit	2.1
Specifications	2.2
General Information	2.3
Trouble Shooting	2.4
Pressure Tests	2.5
Towing Procedure	2.6
Flushing The Hydraulic System	2.7
Start - up Procedure	2.8
Gear Pump Replacement	2.9
Tandem Pump Replacement	2.10
Tandem Pump Parts Diagram	2.11
Drive Motor	2.12
Torque Specifications	2.13

Section 3

Final Drive

Specifications and Maintenance	3.1
Lubrication	3.2
Drive Chain	3.3
Drive Motor Sprocket	3.4
Axle Assembly	3.5
Trouble Shooting	3.6

Section 4

Controls

Steering	4.1
Foot Pedals	4.2
Hand Controls	4.3
Throttle	4.4
Restraint Bar	4.5
Seat Belt	4.6
Parking Brake	4.7
Trouble Shooting	4.8

TABLE OF CONTENTS

Section 5	Electrical
Specifications	5.1
Wiring Schematics	5.2
Instrumentation	5.3
Ignition Switch	5.4
Engine Glow Plugs	5.5
Battery	5.6
Electrical Panel	5.7
Starter Circuit	5.8
Charging Circuit	5.9
Safety Circuit	5.10
Auxiliary Circuit	5.11
2 Speed Option	5.12
Trouble Shooting	5.13
Section 6	Main Frame
Quick - Tach.....	6.1
Boom Arms	6.2
Boom Support.....	6.3
ROPS	6.4
Rear Door.....	6.5
Section 7	Engine
Maintenance.....	7.1
Cylinder Head.....	7.2
Replacement.....	7.3
Specifications.....	7.4
Trouble Shooting	7.5
Section 8	Maintenance & Specifications
Maintenance.....	8.1
Trouble Shooting	8.2
Special Tools.....	8.3
Specifications.....	8.4
Decals.....	8.5

SECTION 4 CONTROLS

Steering	4.1
Steering Control System Illustrations	pg. 4-2
Neutral Adjustment	pg. 4-3, 4-5
Tracking Adjustment (Speed)	pg. 4-6
Control Lever Replacement	pg. 4-7
Foot Pedals	4.2
Foot Pedal System Illustration	pg. 4-8
Angle Adjustment	pg. 4-9
Pedal Replacement	pg. 4-10
Control Cross Shaft Replacement	pg. 4-11
Hand Controls	4.3
Hand Control System Illustration	pg. 4-12
Cable Replacement	pg. 4-13
Angle Adjustment	pg. 4-14
Control Lever Replacement	pg. 4-15
Throttle	4.4
Throttle System Illustration	pg. 4-16
Adjustment	pg. 4-17
Throttle Cable Replacement	pg. 4-18
Restraint Bar	4.5
Restraint Bar System Illustration	pg. 4-19
Gas Spring Replacement	pg. 4-20
Restraint Bar Replacement	pg. 4-21
Seat belt	4.6
Inspection	pg. 4-22
Replacement	pg. 4-23
Parking Brake	4.7
General Information	pg. 4-24
Trouble Shooting	4.8
Steering Controls	pg. 4-25
Foot Pedals	pg. 4-25
Hand Controls	pg. 4-25
Restraint Bar	pg. 4-25



STEERING 4.1

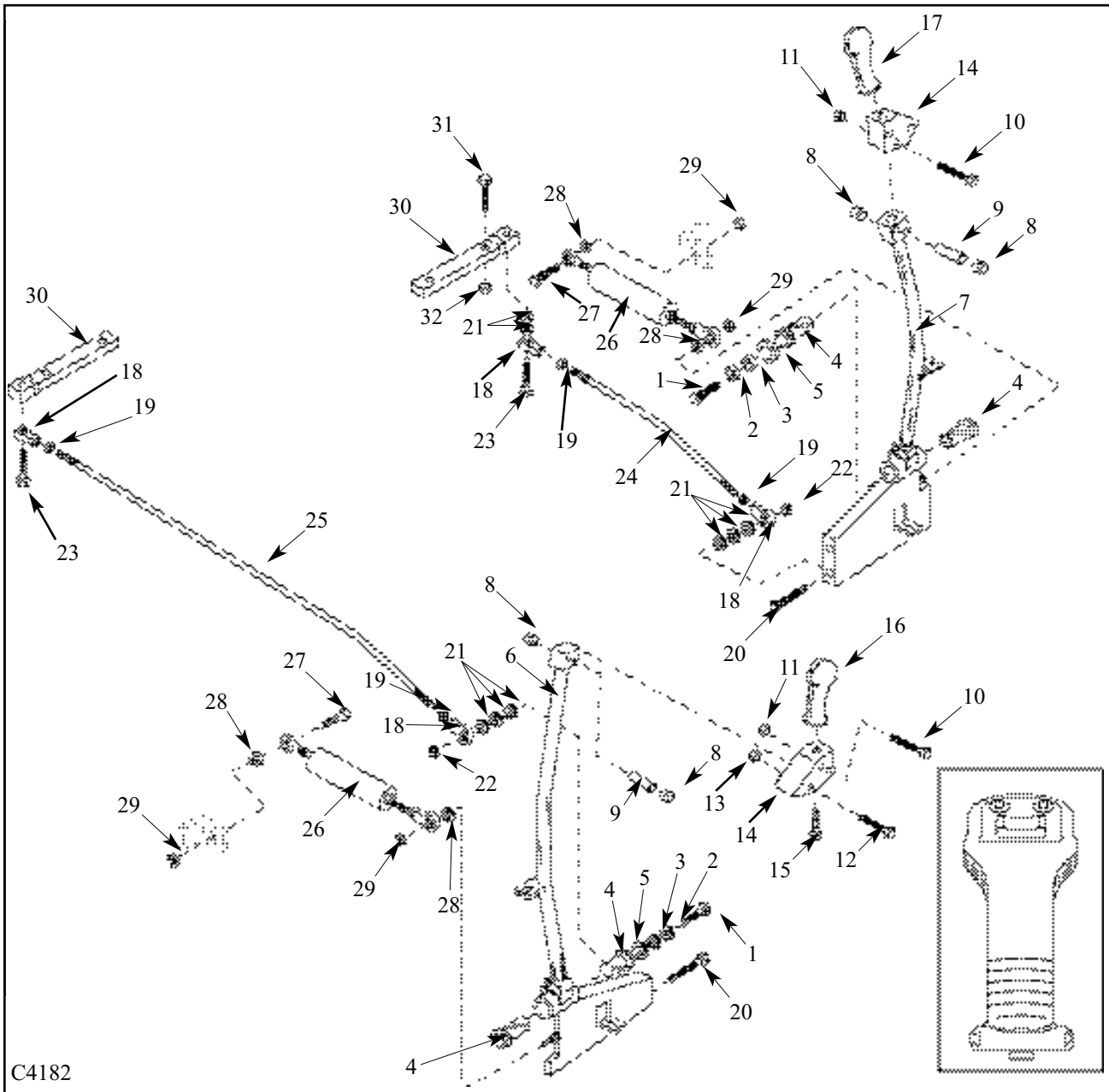

C4182

- | | | |
|---------------------------------|------------------------------------|--------------------------|
| 1 Bolt, Hex 3/8 x 3/4 | 13 Nut, Nylok Hex 5/16 | 23 Hex, Bolt 7/16 x 2 |
| 2 Washer, Flat 3/8 | 14 Lever Base Welded Assy | 24 Bar, CF RD Linkage LH |
| 3 Washer, Lock 3/8 | 15 Bolt, Ergonomic Handle w / hole | 25 Bar, CF RD Linkage RH |
| 4 Bushing, Flange 1" ID Nylon | 16 Handle, Ergonomic Plain | 26 Hydroback Assy |
| 5 Washer, Fender 3/8 | 17 Handle, Ergonomic w/Rocker & 2 | 27 Bolt, Hex 3/8 x 1 1/2 |
| 6 Lever, RH Control Welded Assy | 18 Rod End Assy | 28 Washer, 3/8 x 5/8 |
| 7 Lever, LH Control Welded Assy | 19 Nut, Hex 7/16 | 29 Nut, Nylok 3/8 |
| 8 Bushing, Flange 7/16 x 9/16 | 20 Bolt, Hex 7/16 x 1 1/4 | 30 Pintle Lever Assy |
| 9 Tube, Handle Spacer | 21 Washer, Lock 7/16 | 31 Bolt, Hex 5/16 x 2 |
| 10 Bolt, Hex 1/4 x 1 3/4 | 22 Nut, Nylok 7/16 | 32 Nut, Nylok Hex 5/16 |
| 11 Nut, Jam Locking 1/4 | | |
| 12 Bolt, Hex 5/16 x 2 | | |

STEERING 4.1

Neutral Adjustment

IMPORTANT

If you are unfamiliar with the control operations of the loader, read the Owner's / Operator's Manual beforehand.

The steering levers are equipped with a spring centering device called a hydroback. The hydroback returns the steering lever to neutral position when the steering levers are not being operated.

This feature automatically keeps the loader in neutral whenever the engine is started, or when the control levers are released.

If the loader creeps, or is not in neutral, when the engine is started or the steering lever is released from forward or reverse position, the hydroback device may need to be adjusted, repaired or replaced.

- 1 Raise the boom arms, engage the boom support pins and shut off the engine. Raise and block the loader securely off the ground.
- 2 Remove the seat and hydrostatic shield.(fig. C3557) Note the location of the hydroback. (fig. C4655)
- 3 Cycle the control lever while watching the hydroback action. The hydroback should return the lever to a neutral position.
- 4 Check the rod ends on each end of the hydroback. They must be free of any play. Replace the rod ends if any play or slack is noticed. (fig. C4656)
- 5 If the control lever is able to move slightly without spring tension returning it to neutral, the hydroback needs adjusted.



WARNING

Never work under the boom arms without the boom supports engaged.

IMPORTANT

Repairs or adjustment to the control lever system may change the loader neutral position. Make sure the loader is raised securely off the ground before restarting the engine.

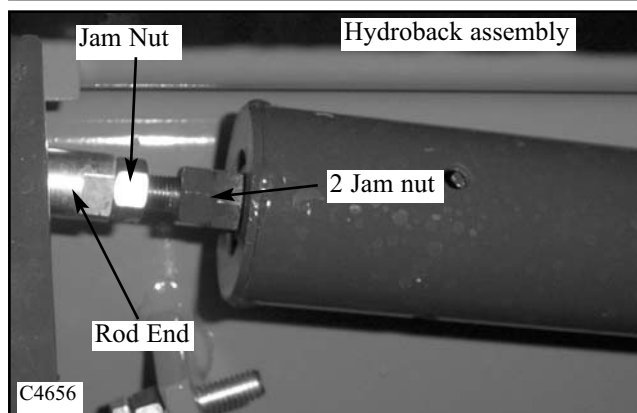
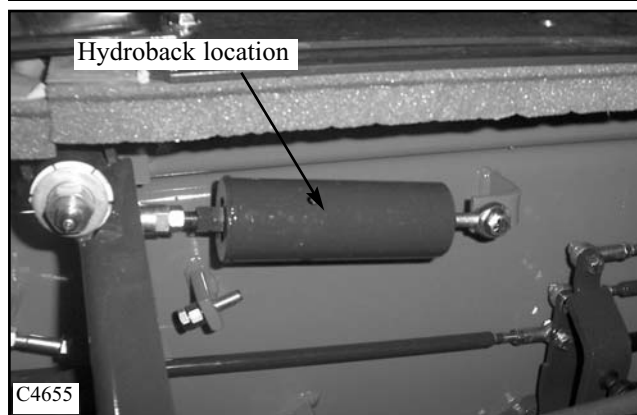

STEERING 4.1

Neutral Adjustment (con't.)

- 6 Loosen the 2 jam nuts next to the main body. (fig. C4655)
- 7 Turn the 2 nuts away from the main body of the hydroback.
- 8 Cycle the control lever several times.
- 9 Push the control lever rearward until you feel resistance. Stop.
- 10 Turn the 2 jam nuts back toward the main body of the hydroback until the nut just touches the flat washer.
- 11 Cycle the control lever again checking for a neutral position. If the lever returns to neutral, tighten the 2 jam nuts together. If the hydroback still does not center, the hydroback has internal damage or wear. Replace the hydroback assembly with a new one.

4

IMPORTANT

Repairs or adjustment to the control lever system may change the loader neutral position. Make sure the loader is raised securely off the ground before restarting the engine.

Hydro Back Replacement

Replacing the hydro back changes the steering control lever angle. To correctly set the angle after the hydro back has been installed:

- 1 Replace the hydro back by removing the 2 bolts located at either end of the hydro back assembly.
- 2 Install the hydro back in the reverse order. Check the steering control rod ends and replace them now if they are worn.
- 3 Use an angle finder to check the base measurement angle. (fig. C3552) Note the angle the loader is sitting at. This measurement will have to be added or subtracted to the next measurement to give the most accurate adjustment.
- 4 Attach an angle finder to the most vertical part of the control lever. (fig. C3553)
- 5 Turn the hydro back threaded rod (fig. C4656) in or out of the female rod end to move the control lever to a reading of 5° . Be sure to allow for the base angle measurement. Jam the nut against the rod end when completed.

Make sure there is a minimum of $3/8''$ (6mm) of thread holding the female rod end to the threaded rod.

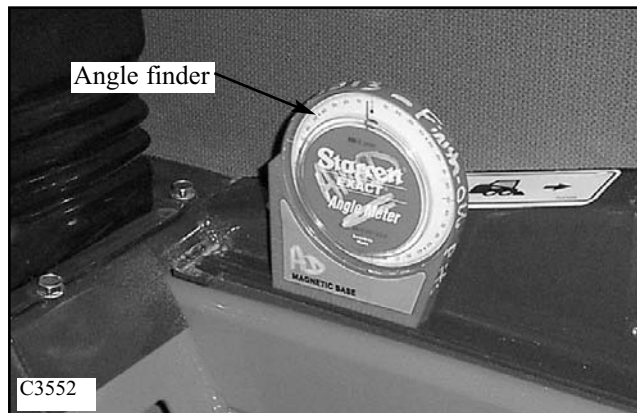
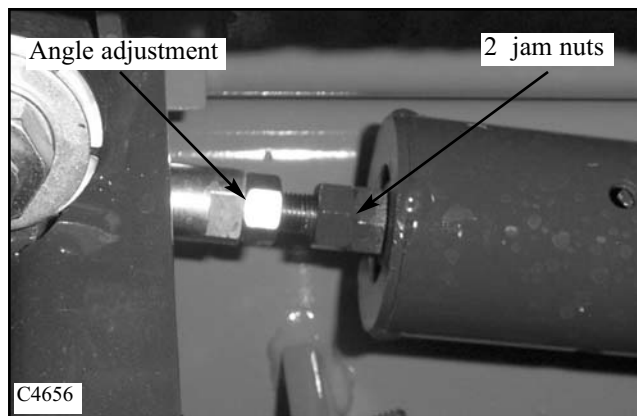
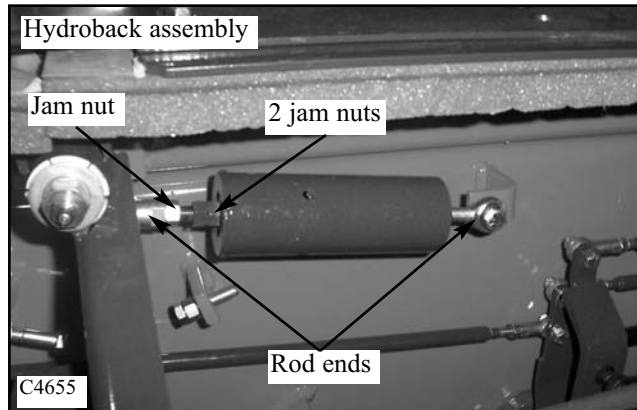

STEERING 4.1

Neutral Adjustment

Before performing the neutral adjustment make sure the hydro back is functioning and adjusted properly. Refer to page 4-3.

IMPORTANT

If you are unfamiliar with the control operations of the loader, read the Owner's / Operator's Manual beforehand.

- 1 Raise the boom arms, engage the boom support pins and shut off the engine. Raise and block the loader securely off the ground.



WARNING

Never work under the boom arms without the boom supports engaged.

- 2 Remove the seat and hydrostatic shield. Note the location of the steering control linkage. (fig. C4631)
- 3 Check the control rod end bushings for wear. If any play is present between the bushings and the bolts replace the rod ends.
- 4 Check the pintle lever for tightness on the manual displacement levers on the pump. Tighten the mounting bolt or replace the pintle lever if required. (fig. C4631b)
- 5 If and when all rod bushings and pivot points have been checked for wear or binding, proceed with the neutral adjustment.
- 6 Loosen the jam nuts on the control rod linkage. (fig. C4657) One end of the control rod is RH threads, the opposite end has LH threads.
- 7 Start the engine and release the parking brake.
- 8 Turn the control rod linkage and visually watch the wheels as they turn. Stop turning the control rod linkage when the wheels are in neutral. Tighten the jam nuts against the rod ends and recheck the neutral adjustment.
- 9 Very fine adjustment can be made at the hydro back threaded rod. Adjustment here affects the control lever angle. **Only make minor adjustments using this method.**
- 10 Replace the seat and hydrostatic shield.



WARNING

Repairs or adjustment to the control lever system may change the loader neutral position. Make sure the loader is raised securely off the ground before restarting the engine.

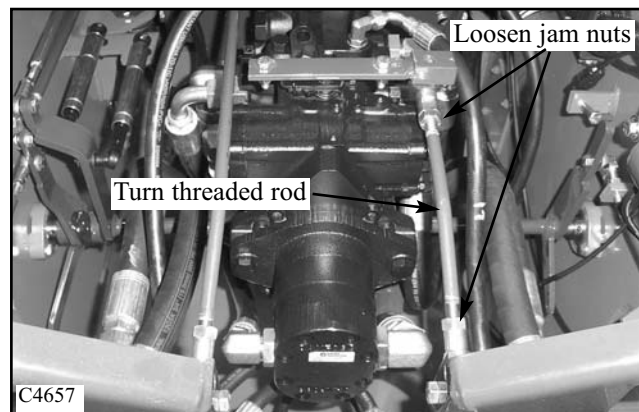
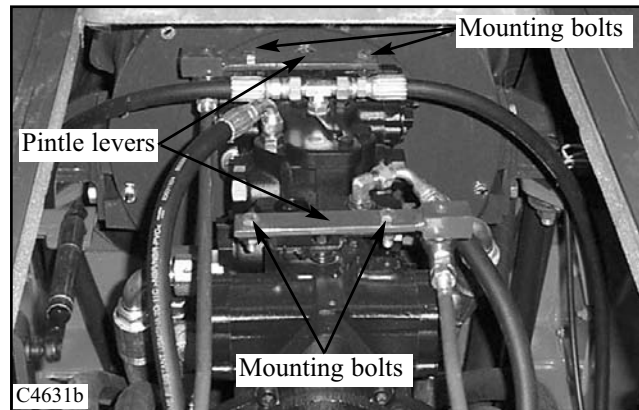
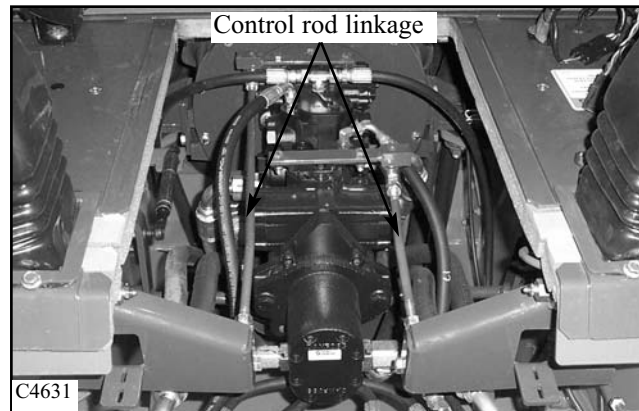

STEERING 4.1

Tracking Adjustment (Speed)

Tracking adjustment, or wheel speed, is set individually for LH and RH sides. If the operator complains the loader does not go in a straight line when the levers are pushed clear forward the limiter stops may need adjustment.

1 Raise the boom arms, engage the boom support pins and shut off the engine. Raise and block the loader securely off the ground.



WARNING

Never work under the boom arms without the boom supports engaged.

2 Remove the seat and hydrostatic shield. Note the location of the steering control limiter bolts located front and rear of each steering control lever, just below the pivot point.. (fig. C3559)

3 Make sure the neutral adjustments are adjusted correctly. Refer to pages 4- 4 ~ 4-6.

4 If and when all rod bushings and pivot points have been check for wear or binding, proceed with the wheel speed adjustment.

5 Start the engine and release the parking brake. Adjust the engine rpm to the full high idle position. Refer to Section 7 to verify engine rpm.



WARNING

Raise the loader securely off the ground before starting the engine.

6 Using an rpm surface speed measuring tool (Thomas P/N 43981) check each wheel speed in the forward and reverse direction. Repeat for opposite side. (fig. C3560)

7 Correct wheel speed is set evenly at 73 rpm (255) or 81rpm (250) forward and reverse for both sides.

8 If adjustment is necessary, loosen the jam nut (fig. C3559) and turn the limiter bolt in to increase wheel speed or out to slow it down.

9 Tighten the jam nut and retest the speed adjustment. Repeat if necessary.

10 Replace the seat and hydrostatic shield.

Note: If the wheel speed does not meet the above specification, check the engine rpm. Refer to Section 7.

If the engine rpm checks out good you may need to check for hydrostatic problems such as drive motor seal leakage etc. Refer to Section 2 for testing procedures.

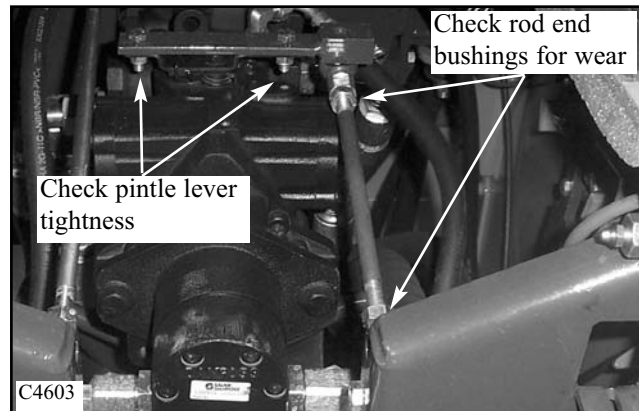
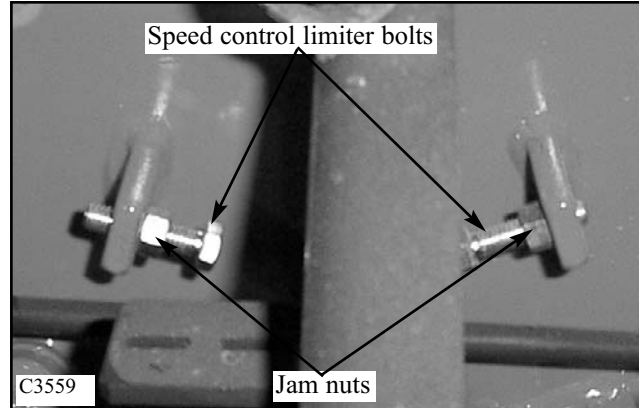

4

STEERING 4.1

Control Lever Replacement

1 Raise the boom arms, engage the boom supports and shut off the engine. Raise the loader securely off the ground to prevent accidental engagement of the drive functions upon restarting the engine.



WARNING

Never work under the boom arms without the boom supports engaged.

- 2 Remove the seat and hydrostatic shield.
- 3 Remove the screws holding the bellows to the control lever cover. (fig. C3561) Slide the bellows over the control handle and remove from the loader.
- 4 Remove the two bolts from the lever base.
- 5 Remove the control handle by loosening the bolt in the lever base.
- 6 Remove the bolt going through the control rod and hydro back linkage. (fig. C3562)
- 7 Remove the retaining bolt and washers mounting the control lever to it's pivot point. (fig.C4658) The control lever is now free to be removed.
- 8 Replace the control lever in the reverse order. Lightly lubricate the control lever pivot shaft with NLGI grade 00 grease through the grease fitting on control lever mount.
- 9 If necessary, make adjustments to the neutral centering and wheel speed as required. Refer to pages 4 - 4 ~ 4 - 6.

Note: If the loader is equipped with optional electrical accessories operated by control handle mounted switches, the control handle switch wiring will need to be disconnected and transferred to the new steering lever.



WARNING

Repairs or adjustment to the control lever system may change the loader neutral position. Make sure the loader is raised securely off the ground before restarting the engine.

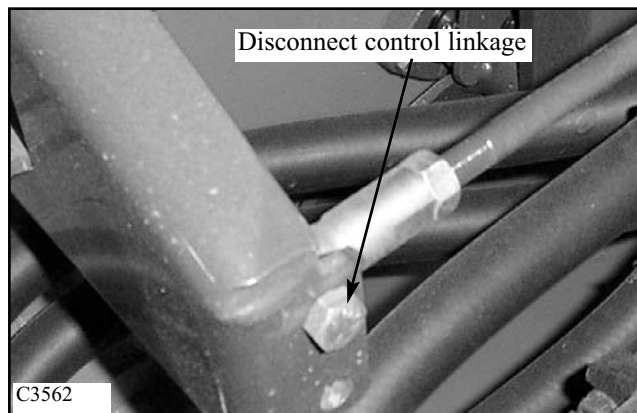
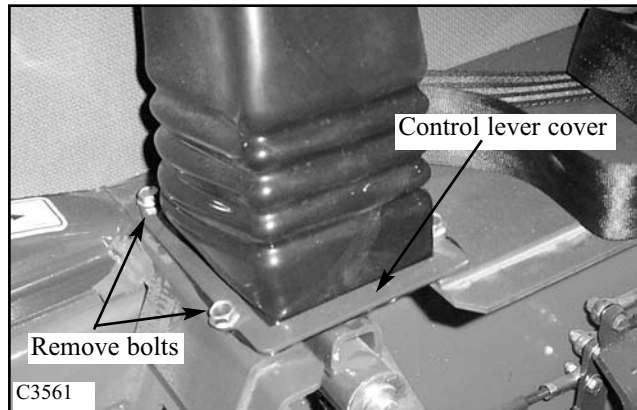

4

FOOT PEDALS 4.2

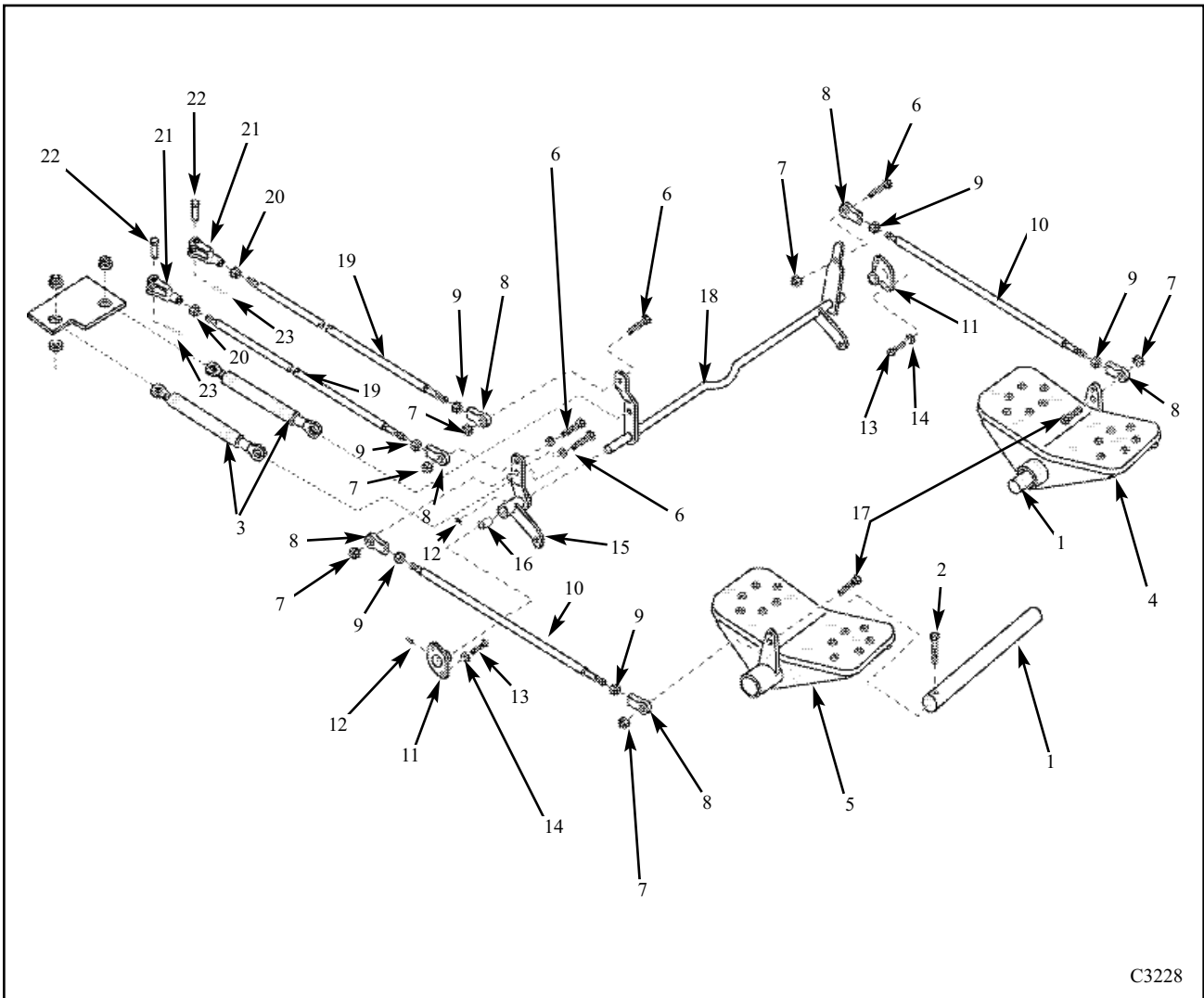

C3228

- | | |
|---|-------------------------------|
| 1. Bar, Foot Pedal Shaft | 13. Bolt, Hex |
| 2. Screw, Cap, Hex Socket head, Stainless | 14. Washer, Lock |
| 3. Dampener, Self-Centering, 9 lbs. | 15. Activator, R.H. Ass'y |
| 4. Pedal, Lift Ass'y (L.H.) | 16. Bearing |
| 5. Pedal, Lift Ass'y (R.H.) | 17. Bolt, Carriage |
| 6. Bolt, Hex | 18. Control Cross Shaft Ass'y |
| 7. Nut, Nylok, Hex | 19. Bar, Valve Control, Rear |
| 8. Rod End Ass'y | 20. Nut, Hex |
| 9. Nut, Hex | 21. Clevis |
| 10. Bar, Valve Control Front | 22. Clevis Pin |
| 11. Bearing, Flanged, 2-Bolt | 23. Cotter Pin |
| 12. Grease Fitting | |

FOOT PEDALS 4.2

Angle Adjustment

The foot pedal angle can be verified and / or adjusted to provide operator comfort and proper pedal travel clearance.

Note: If the operator feels discomfort due to current pedal angles, they may be adjusted to their preference. Be sure to check for pedal travel clearance afterward. Always maintain a minimum of 3/8" (6mm) of thread into the cable clevis and eyelet cable ends. (fig. C3563)

- 1 Make sure the cable ends are screwed onto the cable threads a minimum of 3/8" (6mm). (fig. C3563)
- 2 Place an angle finder on the inner ROPS frame bottom of the loader to find the base measurement. Note the reading. (fig. C3564)

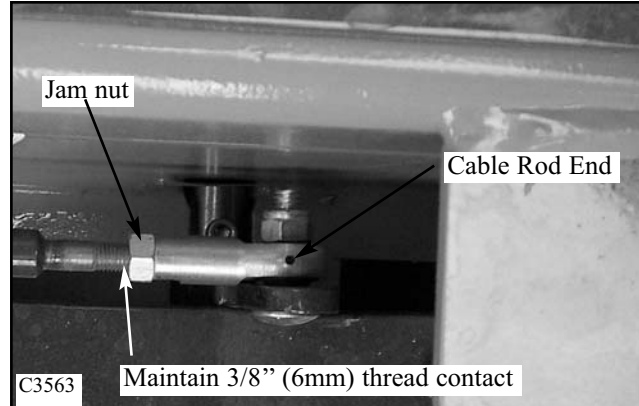

- 3 Place the angle finder on the heel of the pedal to be checked or adjusted. (fig. C3565) Note the reading.

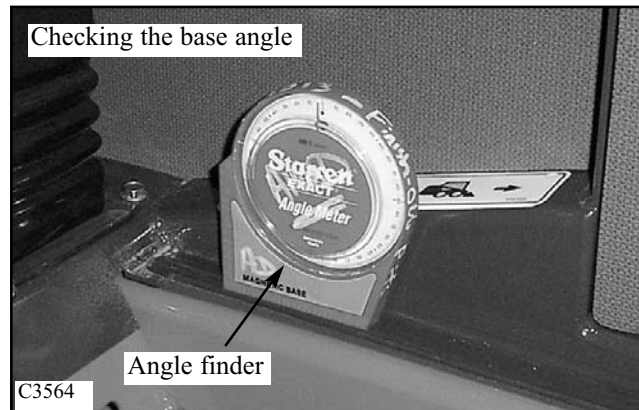

- 4 Adjust the pedal angles by turning the rod ends on the end of the linkage attached to the pedals. Adjust the lift and tilt pedal angle to 20°. Be sure to allow for the base angle measurement taken previously. Example: If the base angle measured 3°, add or subtract that angle from the angle measured on the pedal.

- 5 Check the operation of the foot pedal. Make sure the control valve locking system is functioning properly.

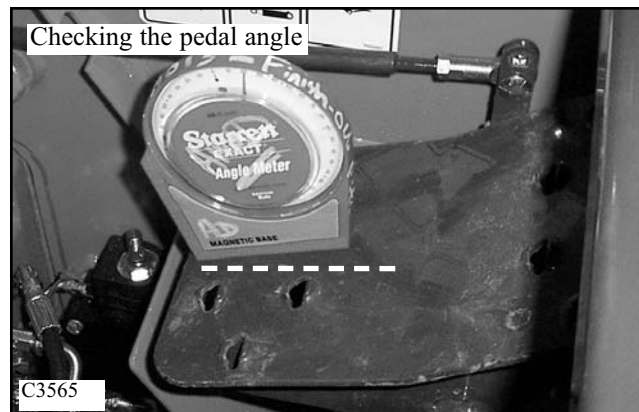

4

FOOT PEDALS 4.2

Foot Pedal Replacement

If the foot pedals or shaft need replacement due to damage or wear. Each pedal has its own shaft.

1 Raise the boom arms, engage the boom supports and shut off the engine.



WARNING

Never work under the boom arms without the boom supports engaged.

- 4**
- 2 Remove the seat and hydrostatic shield.
 - 3 Remove the bolt holding the linkage rod end to the pedal. (fig. C3563)
 - 4 Remove bolts holding the center plate in place and remove the plate. (fig. C3565)
 - 5 Remove the cap screw bolt retaining the foot pedal shaft to the side mount.
 - 6 Remove and save any spacer washer if present.
 - 7 Tip the inside end of the shaft up and remove the complete pedal and shaft assembly together. Keep count of the spacer washer used if present.
 - 8 Replace worn parts as required. The foot pedals are equipped with bronze oillite bushings that are pressed into place and machined to size afterward. They are not serviceable separately. The complete pedal must be replaced.
 - 9 Reinstall pedals in the reverse order. Total pedal movement side to side, end play, should not exceed 1/8".
 - 10 Check the operation of the foot pedal. Make sure the foot pedal does not bind or drag. Make sure the control valve locking system is functioning properly.

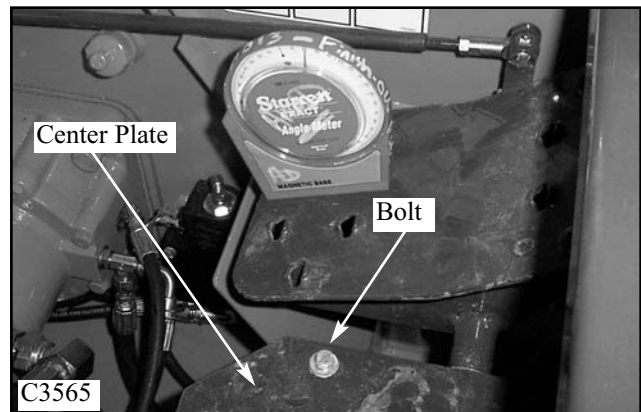
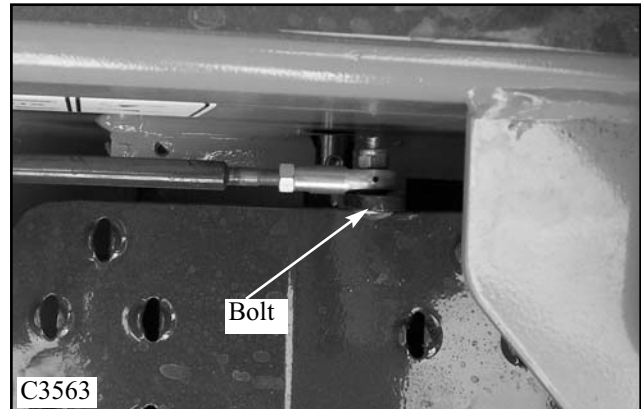

FOOT PEDALS 4.2

Control Cross Shaft

The 250/255 loader uses a control cross shaft to transfer a footpedal or a handcontrol movement to the control valve. The hydraulic control valve is a series type which allows simultaneous use of both lift and tilt circuits. The linkage has a self centering damper that smoothes the movement of the foot pedal.

The control cross shaft has a grease fitting located on the RH activator assy. We recommend that this is greased with NLGI grade 00 grease every 150 hours.

If the control cross shaft or footpedal is binding or has excessive movement, you may need to service this part at your local dealer.

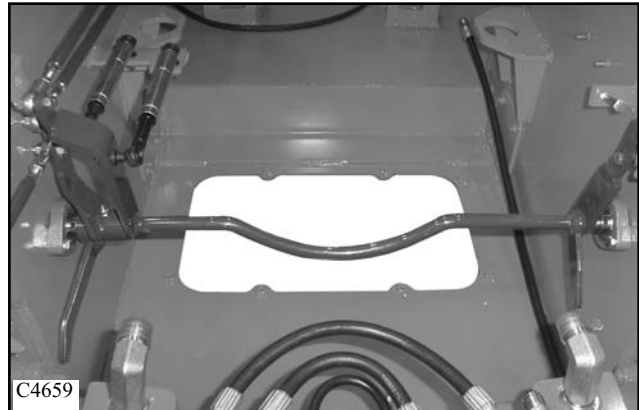

Control Cross Shaft Replacement

Begin the control cross shaft replacement by removing any attachments, raise the boom arms and engage the boom supports. Shut off the engine.

	WARNING
Never work under the boom arms without the boom supports engaged.	

1. Remove the seat and hydrostatic shield.
2. Remove all control linkages from the control cross shaft. Note the location of the lift and tilt control linkages so these do not get reversed. (fig. C4659)
3. Remove the self centering dampers from their mounting location.
4. Remove the bolts in the 2 flange bearing. Use teflon tape on the replacement of these bolt. These are threaded directly into the transmission and need to be sealed correctly.
5. Remove the shaft from the loader.
6. Set the control cross shaft on a work bench and loosen the set screws in the flange bearings. Remove the flange bearings from the assembly and replace if required.
7. Remove the RH activator from the assembly. Inspect the bushing in the activator and replace the assembly if worn. (fig. C4660) Inspect the ends of the shaft, check the shaft for burrs or abnormal wear.
8. Reverse the steps provided for reassembly.
9. Adjust the limiting bolts on the LH pedal or lift pedal. The proper adjustment must be made, the control valve can be damaged by over extending the spool. The control cross shaft provides a small mechanical advantage and needs to limit the stroke. (fig. C4661)
10. Check the angle on the foot pedals. See page 4-9
11. Check the operation of the foot pedal. Make sure the control valve locking system is functioning properly.

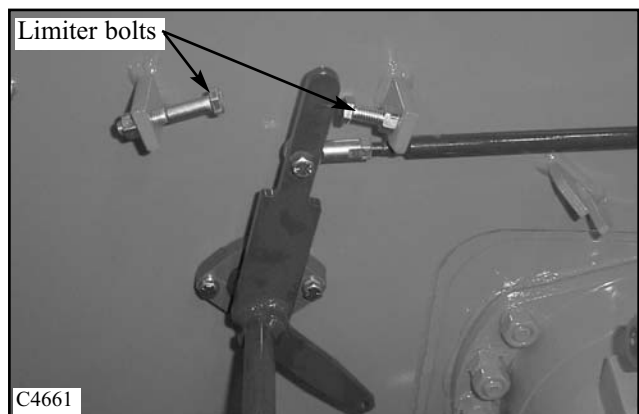
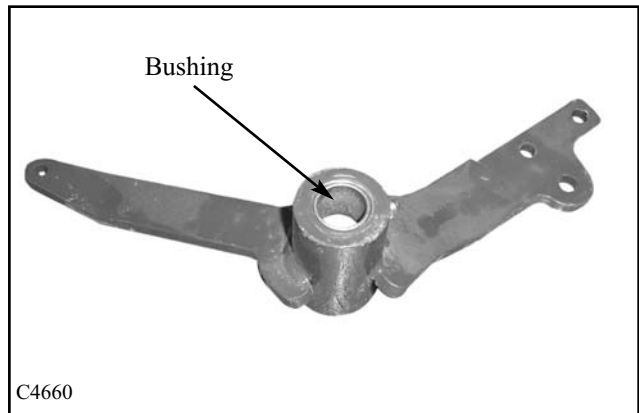

4

HAND CONTROLS 4.3

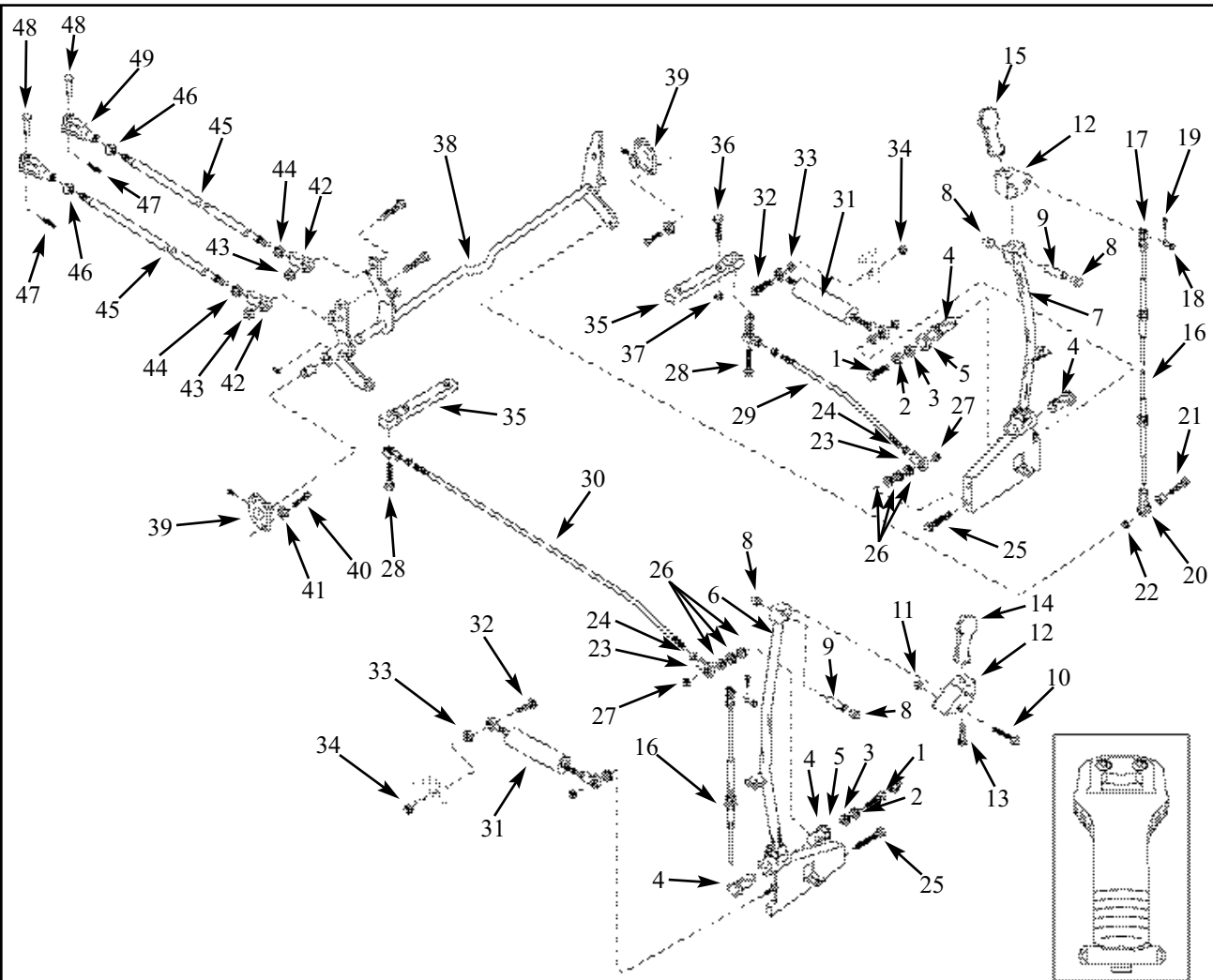

C4167

- | | | |
|--|-----------------------------|------------------------------|
| 1. Bolt, Hex 3/8 x3/4 | 16. Cable, Push/Pull 31" | 33. Washer, 3/8 x 5/8 |
| 2. Washer, Flat 3/8 | 17. Clevis, 1/4" Pin | 34. Nut, Nylok 3/8 |
| 3. Washer, Lock 3/8 | 18. Pin, Clevis 1/4"x3/4" | 35. Pintle Lever Assy |
| 4. Bushing, Flange 1" ID Nylon | 19. Pin, Cotter 1/16"x3/4" | 36. Bolt, Hex 5/16 x 2 |
| 5. Washer, Fender 3/8 | 20. Rod End Assy | 37. Nut, Nylok Hex 5/16 |
| 6. Lever, RH Control Welded Assy | 21. Bolt, Hex 1/4"x1" RH | 38. Control Cross Shaft Assy |
| 7. Lever, LH Control Welded Assy | 22. Nut, Nylok 1/4" | 39. Bearing, Flanged 2-Bolt |
| 8. Bushing, Flange 7/16 x 9/16 | 23. Rod End Assy | 40. Bolt, Hex 5/16 x 1 1/4" |
| 9. Tube, Handle Spacer | 24. Nut, Hex 7/16" | 41. Washer, Lock 5/16" |
| 10. Bolt, Hex 1/4 x 2 | 25. Bolt, Hex 7/16"x 1 1/4" | 42. Rod End Assy |
| 11. Nut, Nylok Jam Hex 1/4 | 26. Washer, Lock 7/16" | 43. Nut, Nylok, Hex 5/16 |
| 12. Lever Base Welded Assy | 27. Nut, Nylok 7/16" | 44. Nut, Hex 5/16 |
| 13. Bolt, Ergonomic Handle w/Hole
Bolt, Hex (No Hole) | 28. Bolt, Hex 7/16 x 2 | 45. Bar, Valve Control Rear |
| 14. Handle, Ergonomic Plain | 29. Bar, CF RD Linkage LH | 46. Nut, Hex 1/4" |
| 15. Handle, Ergonomic w/Rocker &
2 PB Switches | 30. Bar, CF RD Linkage RH | 47. Pin, Cotter |
| | 31. Hydroback Assy | 48. Clevis |
| | 32. Bolt, Hex 3/8 x 1 1/2 | 49. Pin, Clevis |

4

HAND CONTROLS 4.3

Cable Replacement

Check cable ends, eyelets or rod ends, and mounting pins for wear before removing the cable. Replace worn parts when replacing new cables. Cable ends should be inspected every 150 hours of operation.

1 Raise the boom arms, engage the boom supports and shut off the engine.



WARNING

Never work under the boom arms without the boom supports engaged.

2 Remove the seat and hydrostatic shield. Unfasten control lever plates and disconnect the throttle. Slide boots over the handles so that the control levers are easily accessible. (fig. C4631 & C3848)

3 Loosen jam nuts on the cable rod end and eyelet end. (fig. C3847 and fig. C3849)

4 Loosen the cable nuts on the control lever and the transmission plate. (fig. C3849 and fig. C3848)

5 Remove cotter pins from lever base assembly end of the cable and remove the clevis pins. (fig. C3848)

6 Unbolt eyelet end of the cable, then remove the cable.

7 Remove the clevis and eyelet ends of the cable and reuse them if still serviceable.

8 Install the new cable in the reverse order above. There must be a minimum of 3/8" (6mm) of thread engagement into the cable rod end and eyelet ends.

9 Check the operation of the hand controls. Make sure the control valve locking system is functioning properly.

Note: After installation of a new cable, the control lever angle will need to be verified and adjusted if necessary. Refer to page 4-14.

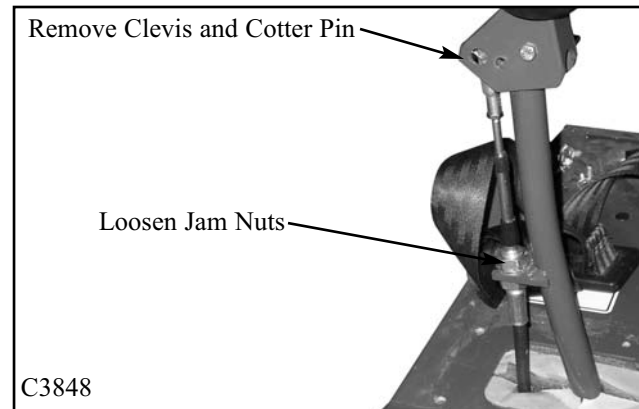
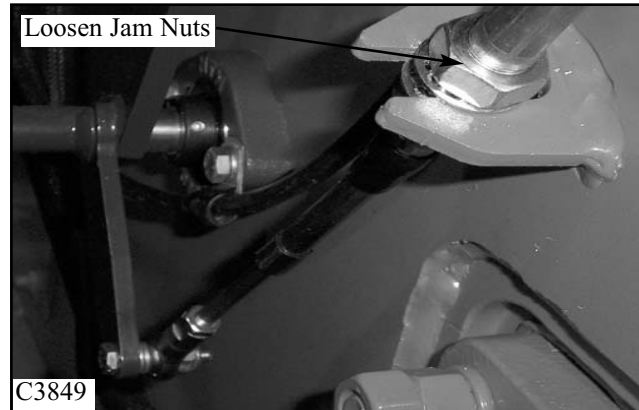
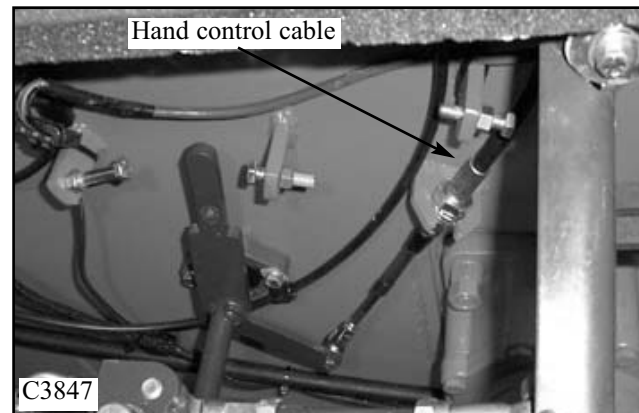
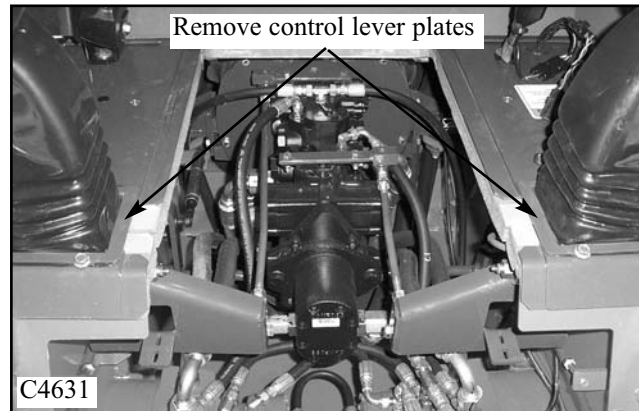

4

HAND CONTROLS 4.3

Angle Adjustment

After changing the control cable, the control lever angle will need to be verified to provide operator comfort and proper pedal travel clearance. Ensure the loader is parked on a level surface.

- 1 Raise the boom arms, engage the boom supports and shut off the engine.
- 2 Unfasten control lever plates and disconnect the throttle. Slide boots over the handles so that the control levers are easily accessible.
- 3 Make sure the cable ends are screwed onto the cable threads a minimum of 3/8" (6mm).
- 4 Place an angle finder on the top of the main tubing to find the base measurement. Take note of the reading.
- 5 Place the angle finder on the control lever as shown (fig. C3877). Note the reading. The correct angle is $8^{\circ} + / - 1^{\circ}$.
- 6 Adjust the angle by moving the cable ends up or down on their mount. Adjustment may be made at the front or the rear of the cable. (fig. C3848 and fig. C3847)
- 7 Tighten all cable nuts and jam nuts on the cable ends. (fig. C3848)
- 8 Cycle the control levers to check for travel clearance.
- 9 Reconnect the throttle to the control lever plate. Fasten the control lever boots to the cab. Replace seat and hydrostatic shield. (fig. C4631)
- 10 Check the operation of the hand controls. Make sure the control valve locking system is functioning properly.

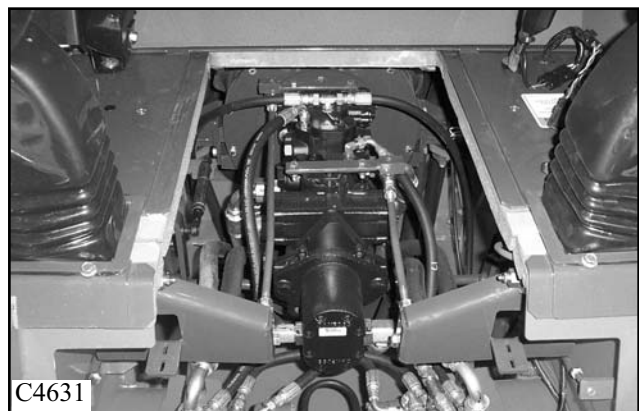
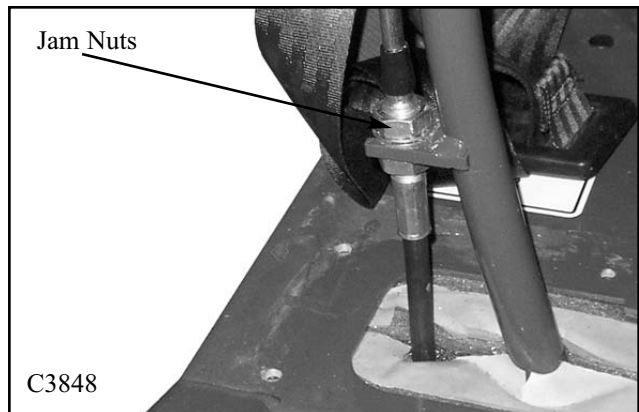
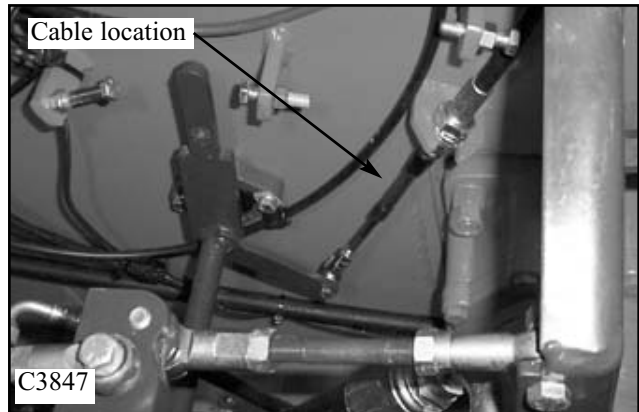

4

HAND CONTROLS 4.3

Control Lever Replacement

1 Raise the boom arms, engage the boom supports and shut off the engine.



WARNING

Never work under the boom arms without the boom supports engaged.

- 2 Remove the seat and hydrostatic shield.
- 3 Remove control lever plates and boots. Disconnect throttle if necessary. (fig. C4631, C3832)
- 4 Remove cotter pins from the lever base assy and cable and remove the clevis pin.
- 5 Loosen the cable nuts and remove cable from mount on control lever. (fig. C3848)
- 6 Remove bolts from control rod.
- 7 Remove mounting bolts for control lever. (fig. C3847)
- 8 Remove control lever saving the plastic sleeve. Replace if necessary.
- 9 Replace all parts in reverse order. Cycle the control lever after installation to check for binding and travel clearance. Check control angles to ensure optimum performance.

10 Check the operation of the hand controls. Make sure the control valve locking system is functioning properly.

NOTE: If the loader is equipped with optional electronic accessories operated by control handle mounted switches, the control handle switch wiring will need to be disconnected and transferred to the new steering lever.

If the control lever functions are sloppy due to excessive wearing of the swivel bushing, the swivel assembly may need replaced.

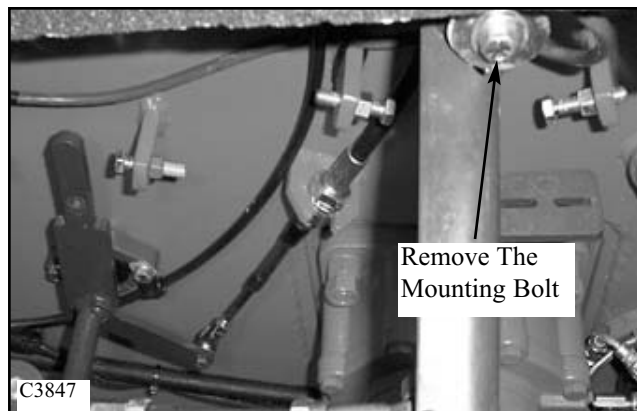
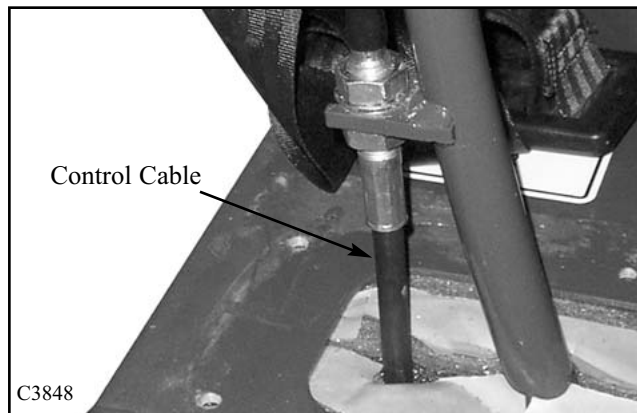
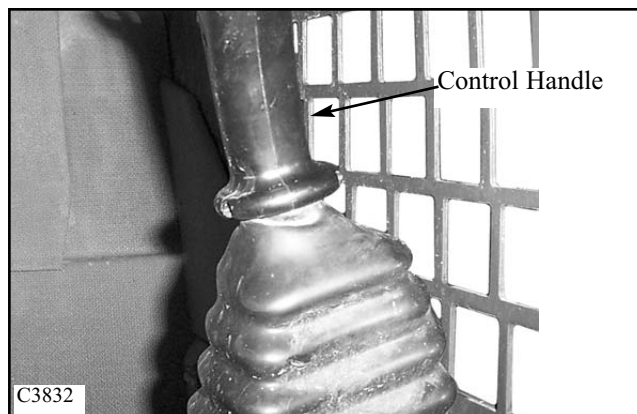
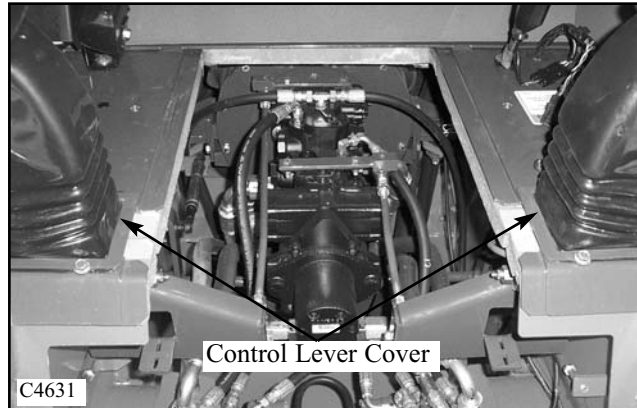

4

THROTTLE 4.4

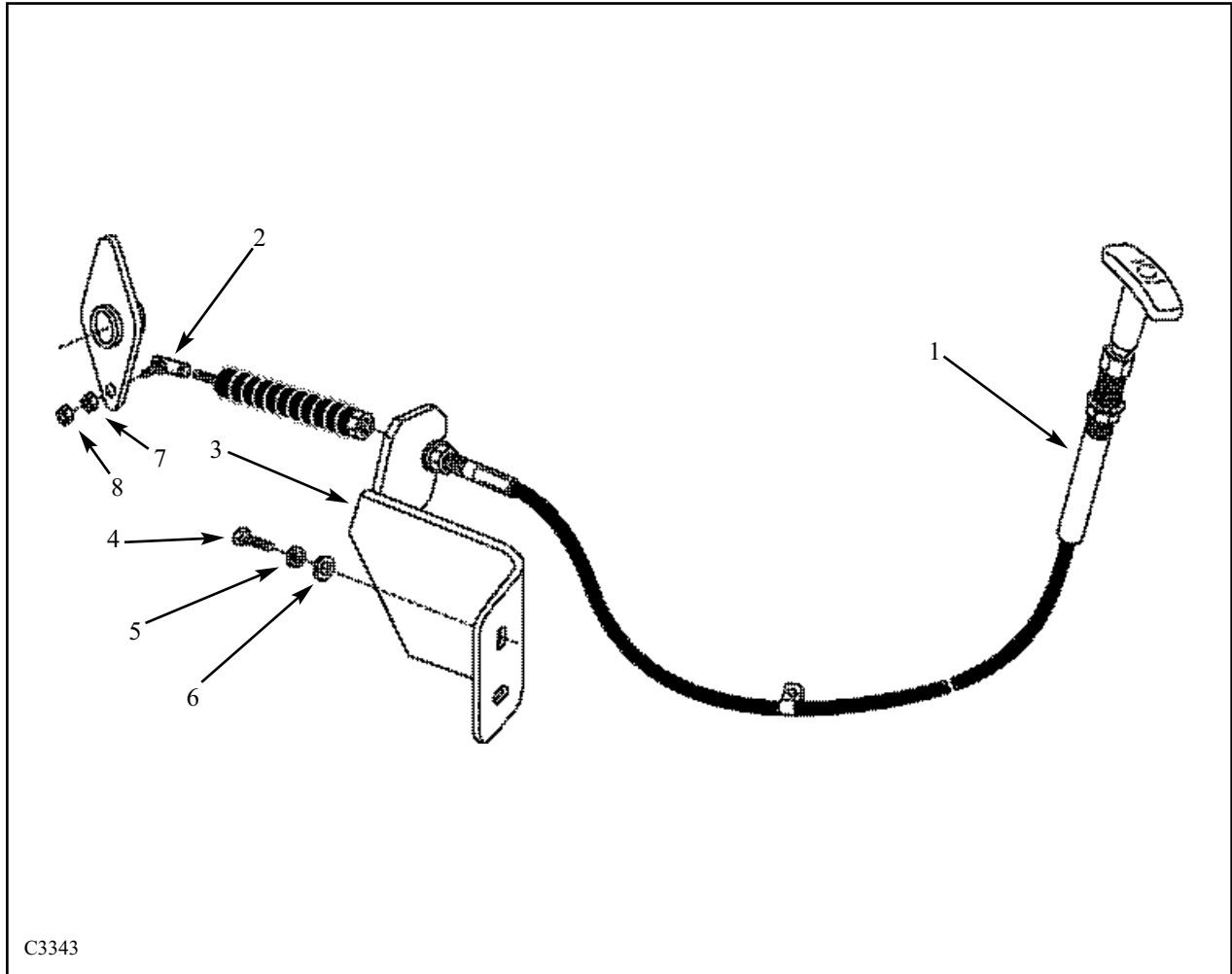

C3343

1. 68" Cable, Turn To Lock
2. Joint, Ball Socket
3. Throttle Bracket Assy
4. Bolt, Hex
5. Washer, Lock
6. Washer, Flat
7. Nut
8. Nut, Jam

4

THROTTLE 4.4

Adjustments

The throttle system can be adjusted for total travel (stroke).

The throttle cable can be set and locked in the full throttle position.



WARNING

Never work under the boom arms without the boom supports engaged.

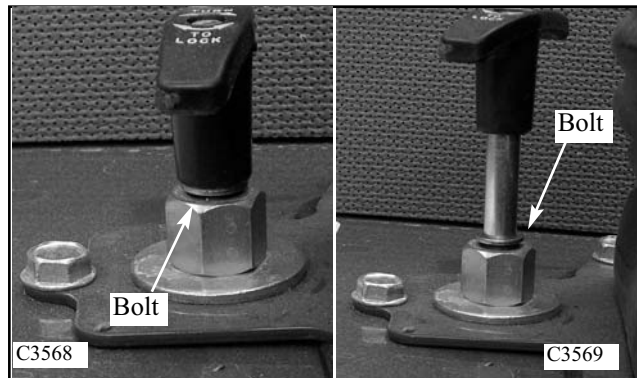

TO CHECK THE THROTTLE TRAVEL:

- 1 Raise the boom arms, engage the boom supports and shut off the engine.
- 2 Open the rear door and locate the engine lever and throttle cable.
- 3 Stroke the throttle lever in the full forward position (pull upwards). (fig. C3569) The throttle cable must touch the limiter bolt stops to acquire full engine speed (internal on the V 3300-TB for the high idle setting).
- 4 Stroke the throttle lever to the idle position (push downward) until it stops. (fig. C3568) The engine lever should touch the limiter bolt to acquire the engines proper low idle speed.
- 5 If adjustment can not be achieved to get the full range of travel, adjust the cable end on the engine lever or the jam nuts on the cable and bracket.

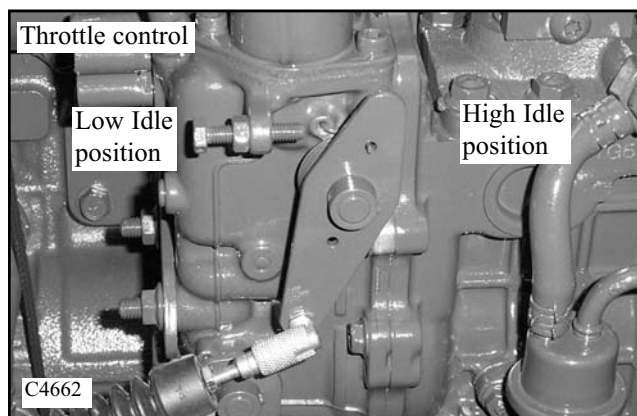

4

THROTTLE 4.4

Throttle Cable Replacement

1 Raise the boom arms, engage the boom supports and shut off the engine.



WARNING

Never work under the boom arms without the boom supports engaged.

- 2 Remove the seat and hydrostatic shield.(fig. C3557)
- 3 Remove the tee handle, nut and washer holding the assembly in place.(fig. C3878)
- 4 Open the rear door, pull ahead on the throttle pivot end and turn to unhook the ball from the socket on the pivot assembly. (fig. C4662)
- 5 Loosen the 2 jam nut on the throttle mounting bracket. (fig. C4663)
- 5 Pull the throttle cable out toward the front of the loader.
- 6 Remove the rod end on the old throttle control cable and transfer it to the new control cable.
- 7 Replace the throttle control cable in the reverse order of above. Adjust the lock nut and tighten against the LH seat support on the underside of the deck.
- 8 Adjust the 2 jam nuts on the throttle mounting bracket to obtain full travel on the cable.(fig. C4663)

NOTE: The throttle cable may need to be adjusted to ensure contact of the engine lever and the limiter bolts for speed settings (up and down). (fig. C4662)

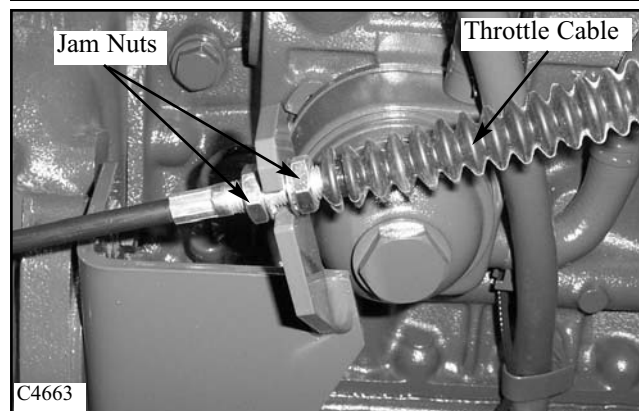
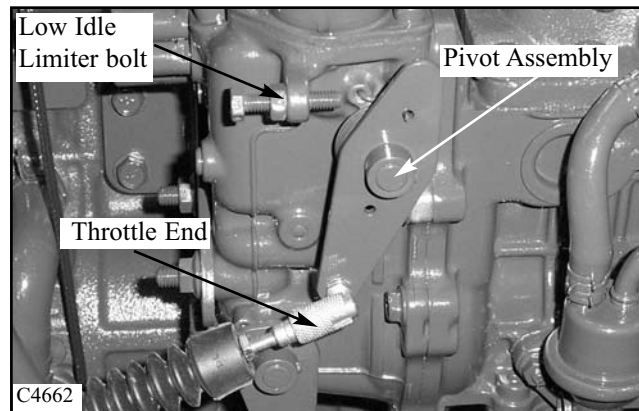
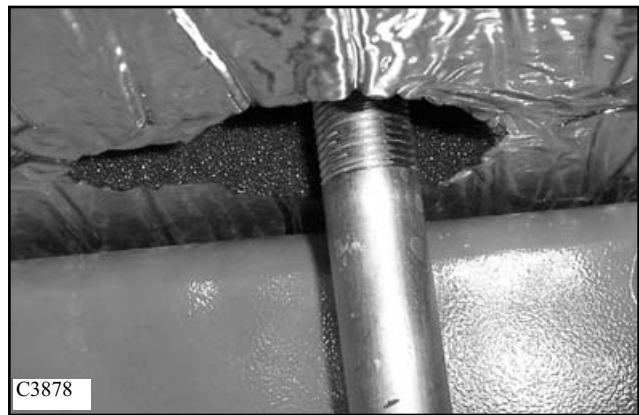
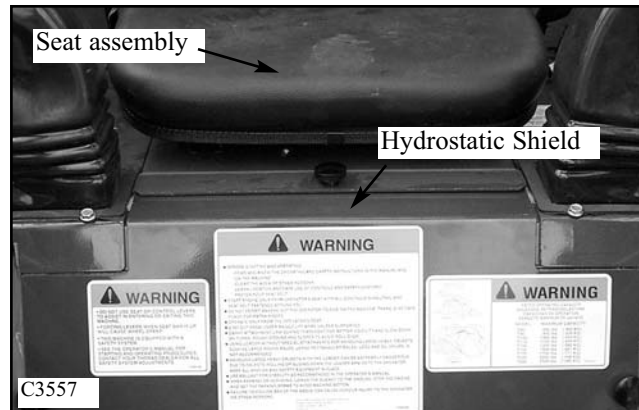

4

RESTRAINT BAR 4.5

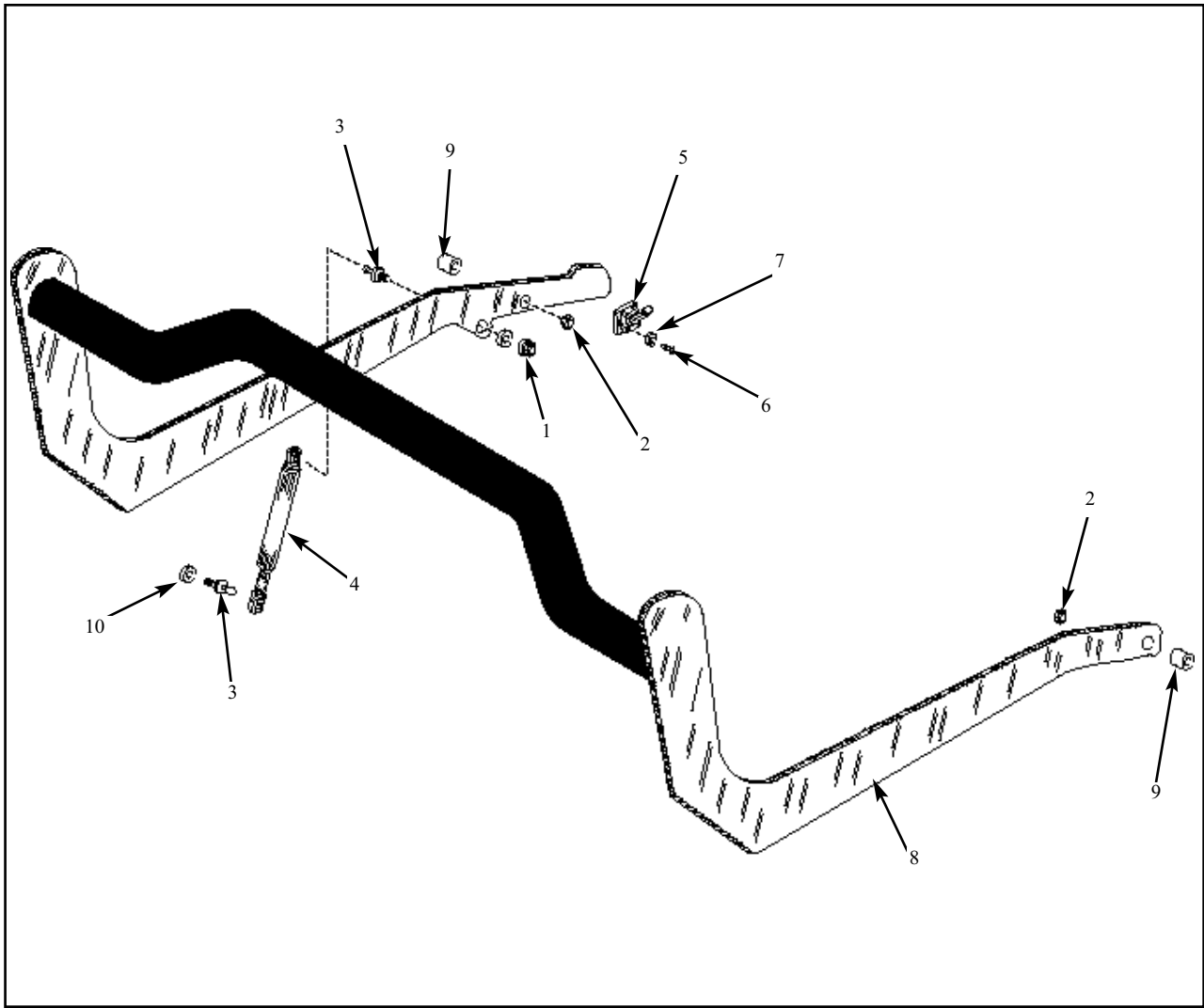

1. Nut, Jam
2. Nut, Nylok
3. Stud. Ball
4. Gas Spring
5. Switch, Dual
6. Screw, Self Tapping
7. Washer, Lock
8. Restraint Bar Ass'y
9. Spacer
10. Lockwasher

4

RESTRAINT BAR 4.5

Gas Spring Replacement

The restraint bar is held up, over head, by means of a gas assist type strut. (gas spring) (fig. C3571)

If the seal in the strut has deteriorated and failed, or the strut rod has been damaged, the restraint bar will not stay in the upright position due to gas pressure loss.

To replace the gas spring assembly:

- 1 Lower the liftarms and park the loader on a level surface. Shut off the engine.
- 2 Insert a small flat bladed screwdriver behind the spring clips (fig. C3572) on either end of the gas spring. Twist the screw driver while pulling out on the gas spring. Repeat for the opposite end.

- 3 Check the ball pivot mounts for wear or damage. (fig. C2043) Replace them if necessary.

- 4 The new gas spring is fully charged and is extended to full length when installed. (fig. C2044)
- 5 Push one end of the gas spring onto the ball pivot mount.
- 6 Raise the restraint bar and attach the opposite end.
- 7 Cycle the restraint bar to verify the new gas spring will hold the restraint bar in the upright position.

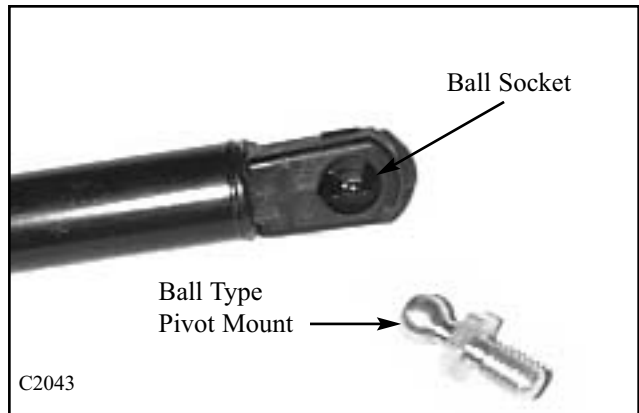
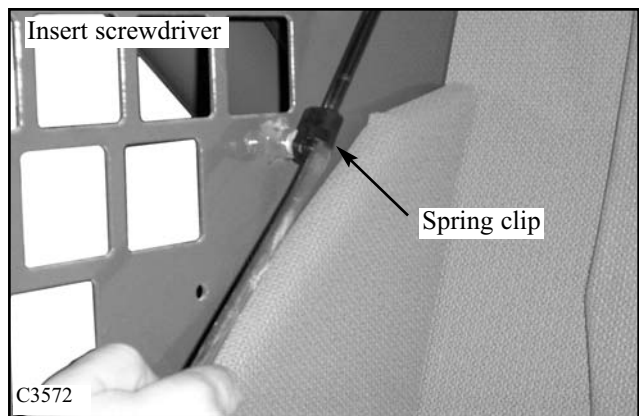
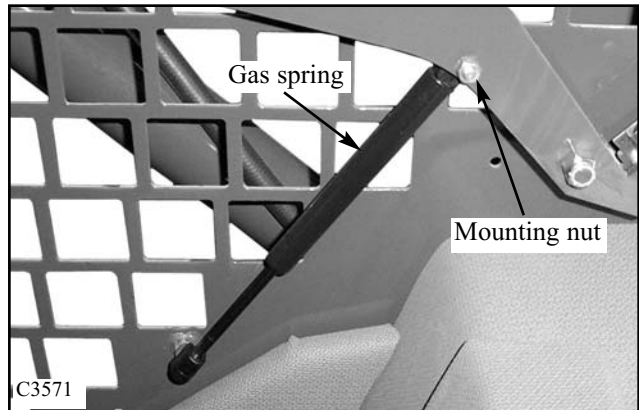

4

RESTRAINT BAR 4.5

Restraint Bar Replacement

- 1 Lower the liftarms and park the loader on a level surface. Shut off the engine.
- 2 Remove the nut from the upper gas spring pivot ball. (fig. C3573) Remove the mount and gas spring together allowing the restraint bar to lower.
- 3 Remove the 2 restraint bar mounting nuts. (fig. C1104) There is one on either side of the restraint bar.
- 4 Squeeze the restraint bar ends inward and remove each side from it's pivot / mounting bolt. Use caution, do not damage the safety switch located to the right rear of the restraint bar.
- 5 Replace the restraint bar in the reverse order. Use new lock nuts on the restraint bar mounts. Tighten to remove slack between the restraint bar and spacer bushings. Do not over tighten. The restraint bar should cycle freely up and down without binding.
- 6 Re- attach the upper ball pivot mount to the restraint bar. Cycle the restraint bar to check proper operation.
- 7 Check to make sure the safety switch is contacting the restraint bar, and functioning properly. This safety switch activates the parking brake when the engine is operating, the operator is seated with the seat belt fastened, and the restraint bar is in the raised position. Lower the restraint bar to release the parking brake.

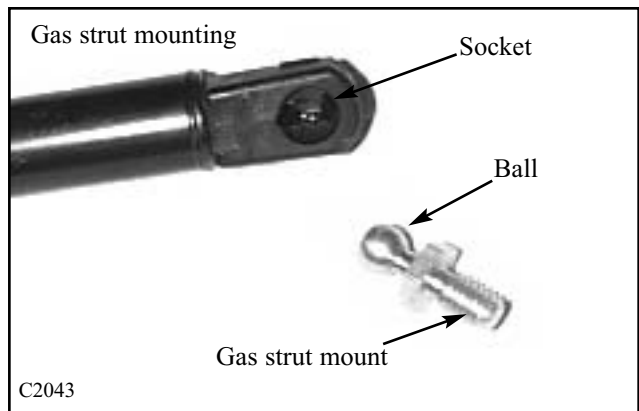
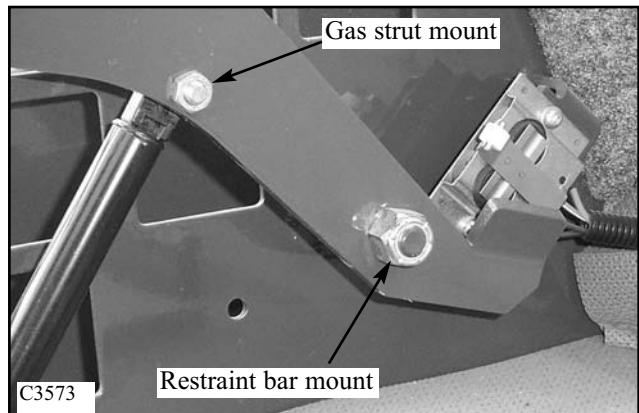
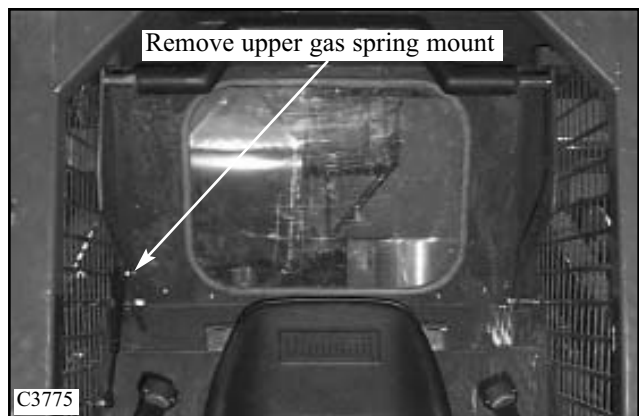
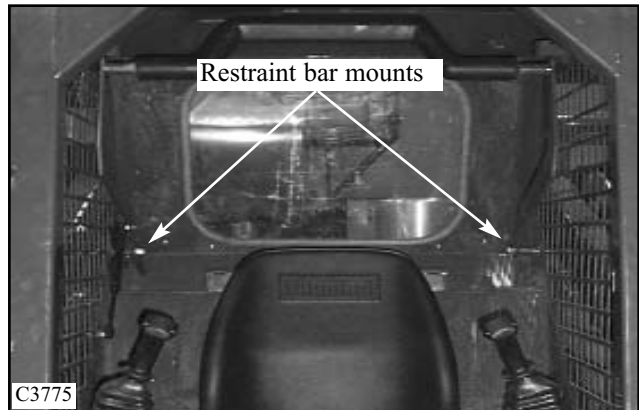

4

SEAT BELT 4.5

Seat belt Inspection

Inspect the seat belt for proper condition on a regular basis.(150 hours) Inspect more often if there is potential exposure of the seat belt to severe environmental conditions. If any components or part of the seat belt system requires replacement, the entire belt system must be replaced.

The 250/255 uses a number of different seat belt systems depending on how your loader is configured. The 255 two speed option uses a 3 point seat belt (fig. C4105) You may want to consult your Thomas dealer for replacement parts.



WARNING

The seat belt system must be inspected at every 150 hours service interval.

There are 5 steps in inspecting the seat belt system:

1 Inspect the belt on the entire system for cuts, fraying, extreme or unusual wear. Check the belt for significant discoloration due to ultraviolet exposure. Inspect for abrasions to the belt webbing caused by dusty or dirty conditions. Most common area of belt wear include the buckle / latch area, the shoulder loop area and any place the belt makes contact with seat.

2 Inspect buckle for proper operation by inserting in latch and listening for an audible click. Verify the buckle is not damaged, cracked or broken. Verify the latch is released when the button is pressed on the buckle. Check the wiring on the buckle and ensure there the wire are in good condition. (fig. C4689)

3 Inspect the latch for proper operation by inserting into buckle. The latch must insert smoothly and you must hear an audible click. Verify proper latching by tugging on belt. The Latch must not be worn, deformed or corroded.

4 Inspect retractor operation. When pulled and released slowly, the seat belt must spool out and retract without locking. On the 3-point seat belt, the belt must move freely through the shoulder loop and pivot freely.

5 Inspect mounting hardware on both sides of seat. Hardware must not be missing, rusted, corroded, or damaged.

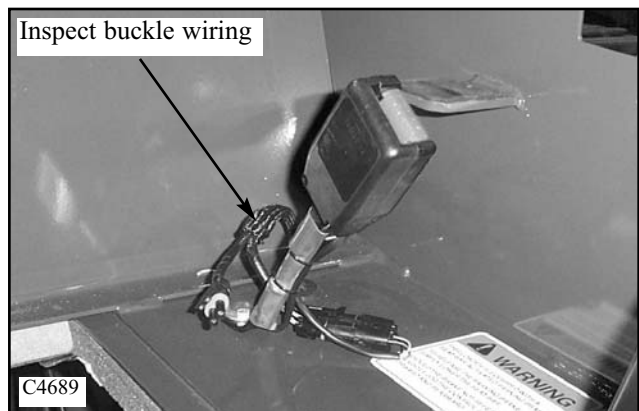
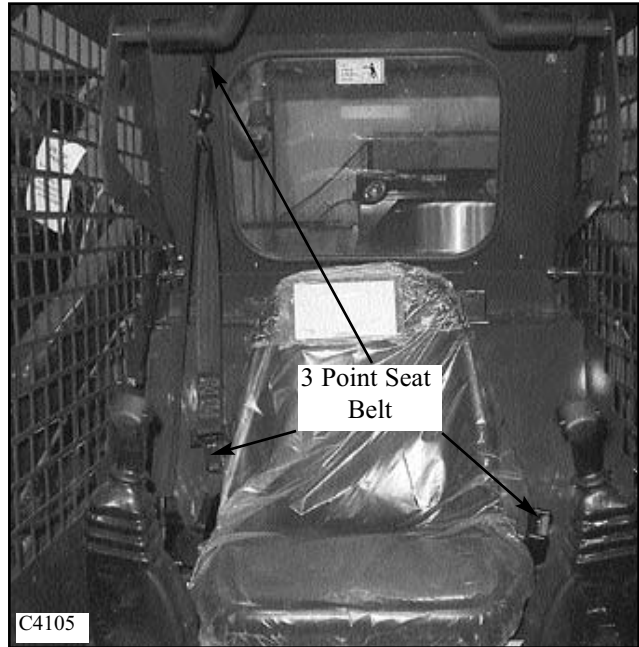

SEAT BELT 4.5

Seat belt Replacement

Begin the seat belt replacement by removing any attachments, raise the boom arms and engage the boom support pins. Shut off the engine.



WARNING

Never work under the boom arms without the boom supports engaged.

- 1 Remove the seat and hydrostatic shield.
- 2 Remove the bolt fastening the retractor to the bracket in the seat support. (fig. C4647) Torque to 40 ft lbs (54Nm) for reassembly.
- 3 Remove the mounting bracket for the retractor from the seat support. Torque to 30 ft lbs (27Nm) for reassembly.
- 4 Remove the bolt fastening the buckle from the seat support. (fig. C4689) Torque to 30 ft lbs (27 Nm) for reassembly. Unplug the wires at the connector fastened at the seat support.
- 5 If you loader contains a 3 point seat belt, remove the shoulder strap section fastened to the rear of the cab. Torque to 45 ft lbs (61 Nm) for reassembly.

Reverse the step provided for reassembly.

- 6 Check the operation of the seat belt system. Be sure the seat belt is not twisted during installation.

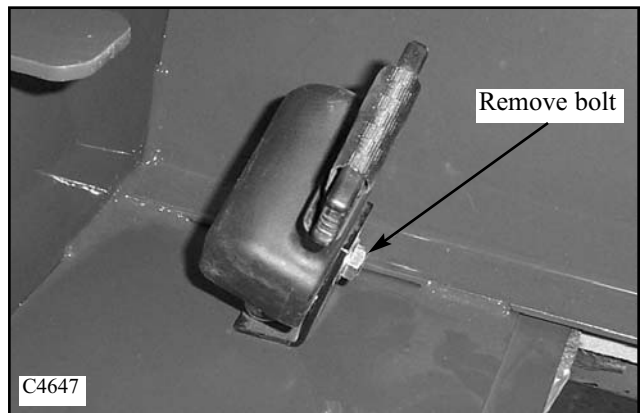
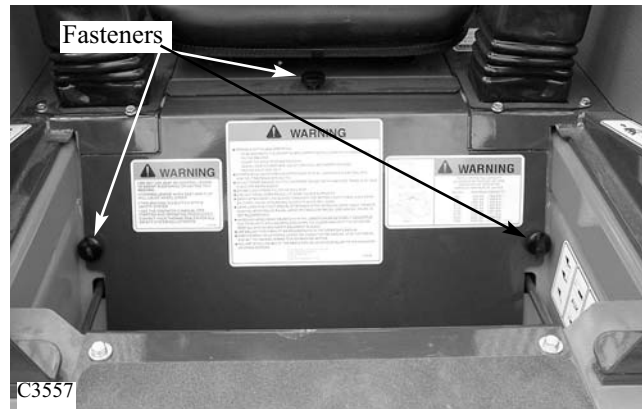

4

PARKING BRAKE 4.6

General Information

Each drive motor contains a set of clutch pack type friction discs that are spring loaded in the engaged position.

The parking brake is inter locked with various safety switches. (fig. C807, C3573, C3574, C3575) The parking brake will only release when the engine is operating, the operator is seated with the seat belt fastened and the restraint bar is in the lowered position.

The parking brake system requires 210 psi (15 bar) hydraulic pressure to release or separate the clutch packs in the drive motors. The hydraulic pressure is provided by the charge pressure relief valve in the hydrostatic tandem pump.

When the engine is operating and all safety switches are functioning and in the closed position, the hydraulic / electric solenoid brake valve (fig. C3575) will allow charge pressure to release the parking brake in the drive motors.

4

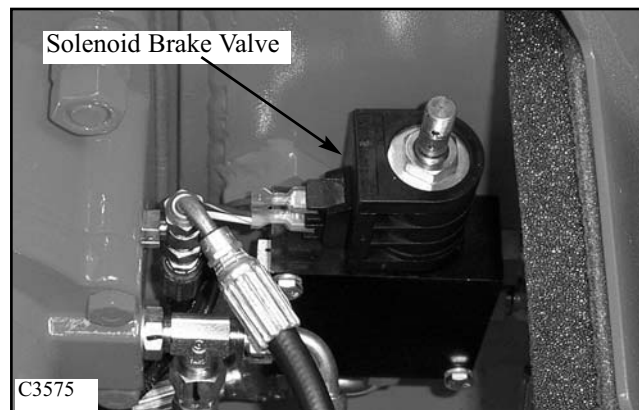
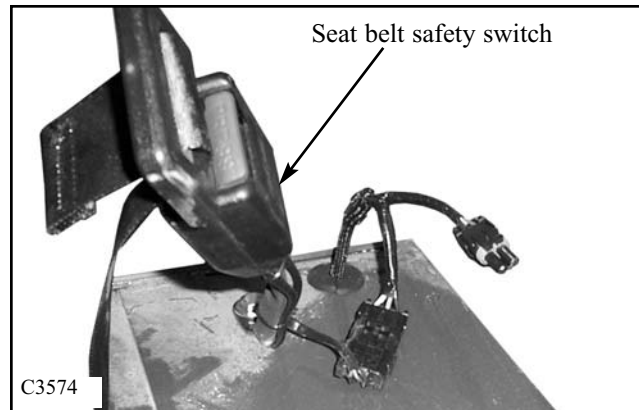
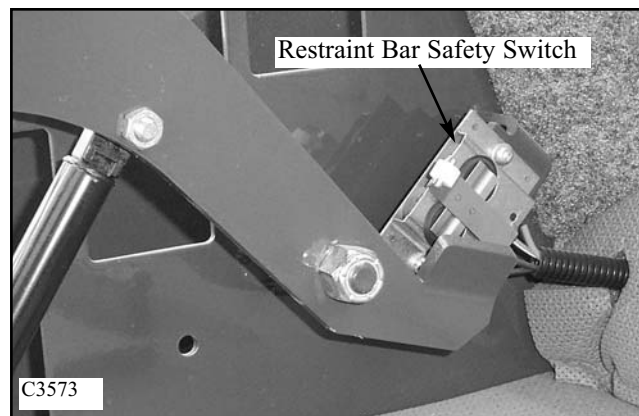
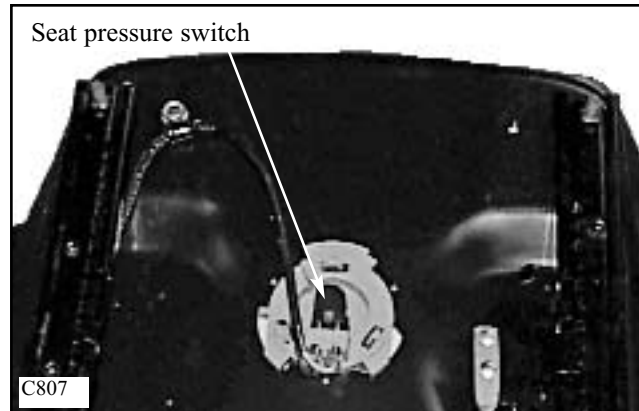

TROUBLE SHOOTING 4.7

Symptom	Cause	Corrective Action	Section
Loader creeps, won't center	Neutral adjustment	Adjust linkage	4.1
	Worn, loose linkage	Replace, tighten parts	4.1
	Binding, dragging parts	Repair, replace	4.1
Steering jerky	Worn, loose linkage	Replace	4.1
	Binding linkage	Repair, replace	4.1
	Linkage adjustment	Adjust	4.1
	Low charge pressure	Repair, replace	2
Loader doesn't track straight	Limiter stops	Adjust	4.1
	Binding linkage	Repair, replace	4.1
	Hydrostatic failure	Repair, replace	2
Boom controls inoperative	Damaged cables, linkage	Replace	4.2, 4.3
	Safety switch (s)	Adjust, replace	5
	Bad electrical ground	Repair	5
	Blown fuse	Replace	5
	Valve lock malfunction	Replace parts	1, 5
	Low hydraulic oil	Replenish	1
	No oil pressure	Make repairs	1
Boom operation slow	Cable linkage	Replace, adjust	4.2, 4.3
	Ax. hydraulics engaged	Disengage	
	Engine RPM low	Adjust	7
	Control valve relief	Adjust, replace	1
	Cylinder seal, damage	Repair, replace	1
Boom controls stiff	Cable wear	Replace	4.2, 4.3
	Pivot wear	Replace parts	4.2, 4.3
	Control valve wear	Repair, replace	1
Auxiliary hyd. inoperative (solenoid control type)	Blown fuse	Replace	5
	Switch (s) failure	Replace	5
	Ax. valve malfunction	Repair, replace	1
	Electrical short	Repair	5
	Bad electrical ground	Repair	5
Brake won't hold	Service plunger on brake valve open	Inspect and service	2
	Brake disc wear or damage	Repair, replace	2
Brake won't release	Blown fuse	Replace	5
	Safety switch malfunction	Adjust, replace	5
	Lack of hydrostatic charge pressure	Test, repair	2
	Brake valve failure	Repair, replace	2



NOTES



4

SECTION 5 ELECTRICAL

Specifications	5.1
General Information.....	pg. 5-2
Wiring Schematic	5.2
ROPS Harness	pg. 5-3 ~ 4
Engine Harness.....	pg. 5-5 ~ 6
Instrumentation	5.3
Left Hand Dash Panel.....	pg. 5-7
Switch and Bulb Replacement.....	pg. 5-7
Right Hand Dash Panel.....	pg. 5-8
Fuel Gauge	pg. 5-8
Fuel Sender	pg. 5-9
Hour Meter.....	pg. 5-9
Ignition Switch	5.4
Ignition Switch Test	pg. 5-10
Engine Glow Plugs	5.5
Ignition Switch Test	pg. 5-10
Glow Plug Test.....	pg. 5-11
Indicator Test.....	pg. 5-11
Dual Battery	5.6
Removal & Inspection	pg. 5-12
Boosting	pg. 5-13
Circuit Breaker.....	pg. 5-13
Electrical Panel	5.7
Fuse & Relay Replacement	pg. 5-14
Starter Circuit	5.8
Schematic.....	pg. 5-15
Charging Circuit	5.9
Schematic.....	pg. 5-16
Safety Circuit	5.10
Schematic.....	pg. 5-17
General Information.....	pg. 5-18
Auxiliary Circuit	5.11
Schematic.....	pg. 5-19
Auxiliary Control Handle	pg. 5-20
Two Speed Option	5.12
Schematic.....	pg. 5-21
General Information.....	pg. 5-22
Trouble Shooting	5.13
Guide	pg. 5-23 ~ 24



SPECIFICATIONS 5.1

Ignition	12 Volts
Grounding	Negative
Alternator Brand	Nippondenso
Alternator Rating	60 Amp
Alternator Type	Internal Regulator
Battery (std)	Dual (2)
Battery Rating	1460 CCA, 125 Reserve Minutes (each)
Battery Type	SERV 3478
Starter Brand	Nippondenso
Pre - Heater	Four (4) Glow plugs
Glow Plug Location.....	Cylinder Head (Pre - combustion chamber)
Circuit Breaker	40 Amp
Fuse Rating:	
Engine Shut Off Solenoid.....	15 Amp
Alternator.....	10 Amp
Safety Circuit.....	10 Amp
Horn	10 Amp
Aux. Hydraulics.....	10 Amp
Cab Heater	10 Amp
Back up Alarm.....	10 Amp
Dome Light.....	10 Amp
Two Speed Control	10 Amp
Starter	40 Amp Relay
Glow Plugs	40 Amp Relay

WIRING SCHEMATIC 5.2

ROPS Harness Connector

Diagram C1741 Legend. Shown is the wire color and function of each pin terminal in the connector plug.

PIN	WIRE COLOR	FUNCTION
1	Purple	Eng. oil press. indicator
2	White	Ignition (30)
3	Red / Wht	Ignition (19)
4	Blk / Wht	Ignition (acc)
5	Tan	Ignition (50)
6	Grey	Seat belt indicator
7	Grey / Wht	Charge (L) indicator
8	Blue / Wht	Hyd. temp. indicator
9	Org / Blue	Fuel level (+) gauge
10	Red / Org	Headlight
11	Brn / Wht	Brake light
12	Wht / Brn	Horn / 2 speed option
13	Pple / Wht	Coolant temp. indicator
14	Pink	Air filter indicator

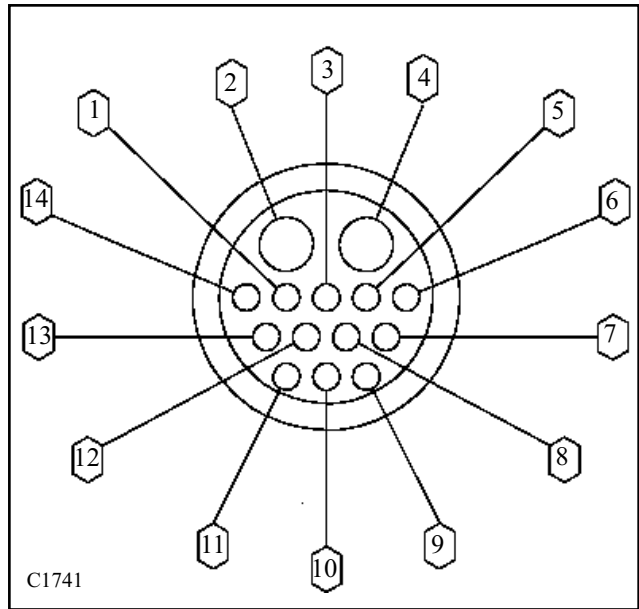

The photographs below and at right show the actual ROPS harness plug connection.

To separate the main electrical harness connection, push the locking tab in the direction of the arrow (fig. C2066) and twist the collar clockwise to release.

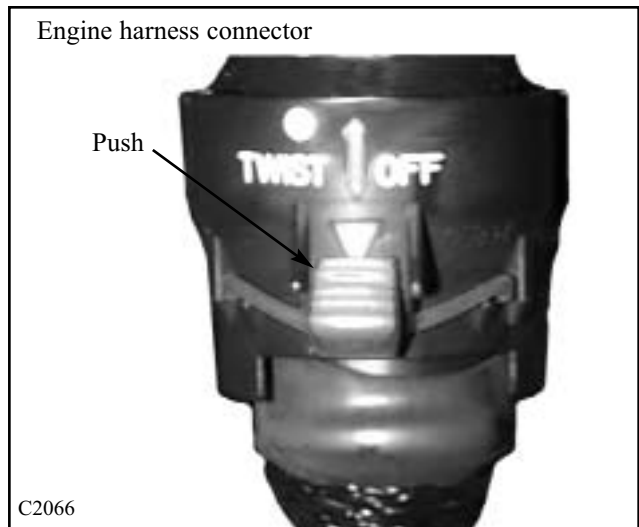
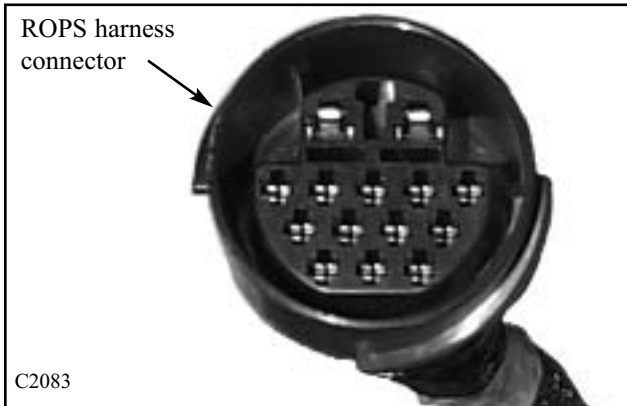
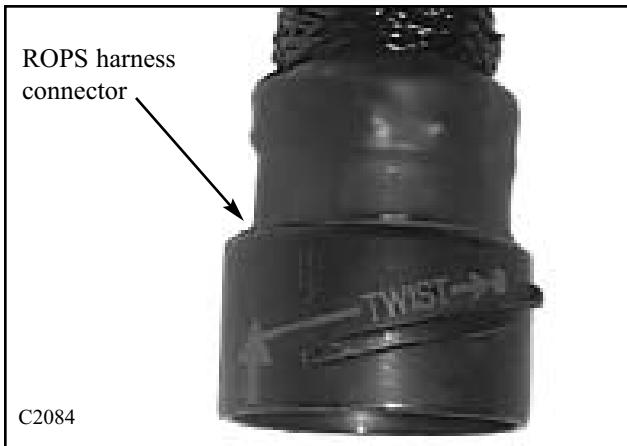
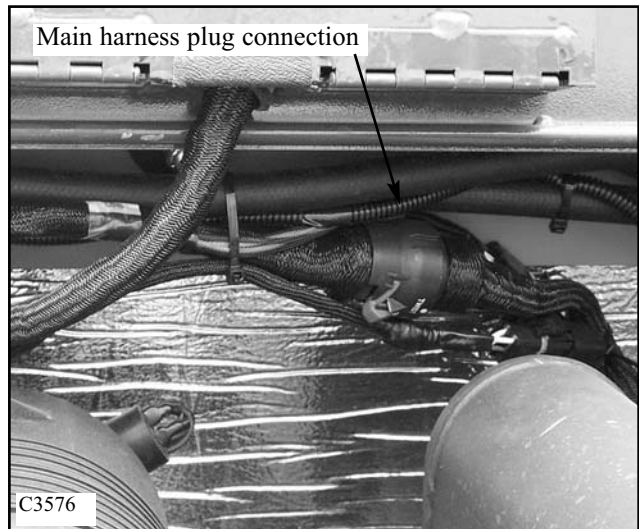

5

WIRING SCHEMATIC 5.2

ROPS Electrical Wiring 250/255

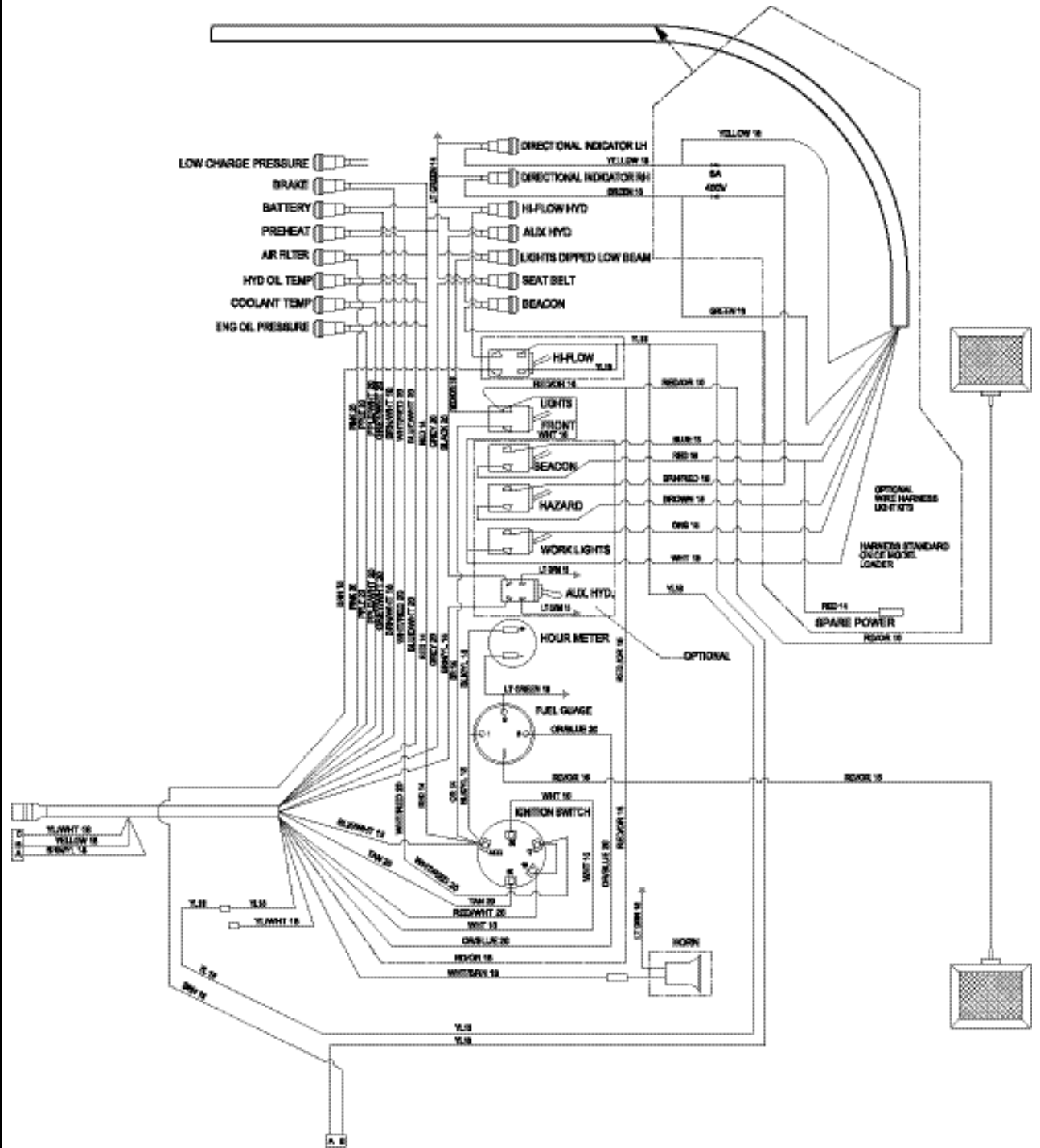

5

C3887

WIRING SCHEMATIC 5.2

Engine Harness Connector

Diagram C1741a Legend. Shown is the wire color and function of each pin terminal in the connector plug.

PIN	WIRE COLOR	FUNCTION
1	Tan	Starter relay
2	Blk / Wht	Fuse block
3	Red / Wht	Glow plug relay
4	White	Circuit breaker
5	Purple	Engine oil pressure
6	Pink	Air filter
7	Pple / Wht	Coolant temperature
8	Wht / Brn	Horn button
9	Brn / Wht	Brake light switch
10	Red / Org	Rear light
11	Org / Blue	Fuel level (+)
12	Blue / Wht	Hydraulic temperature
13	Grey / Wht	Alternator (L)
14	Grey	Seat Belt

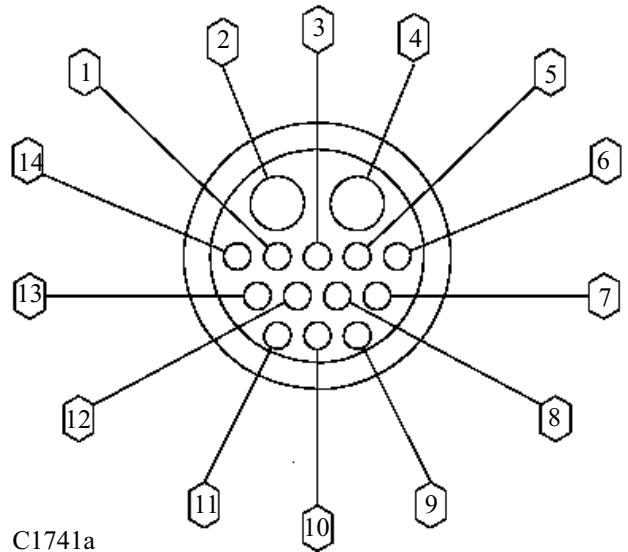

The photographs below and at right show the actual Engine harness plug connection.(fig. C4664)
To separate the main electrical harness connection, push the locking tab in the direction of the arrow (fig. C2066) and twist the collar clockwise to release.

Engine plug



Main harness plug connection

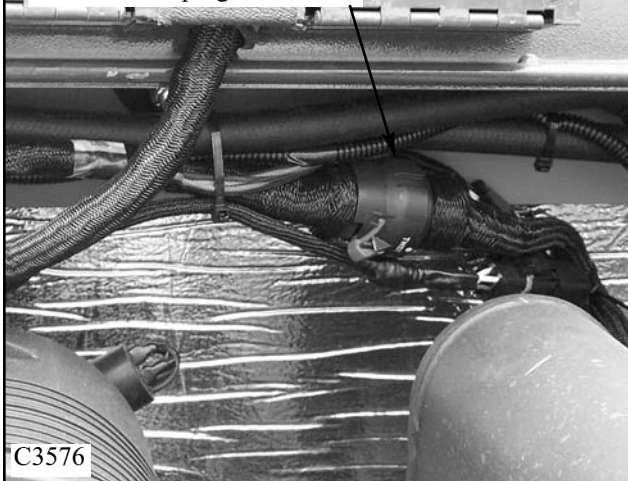

Engine plug

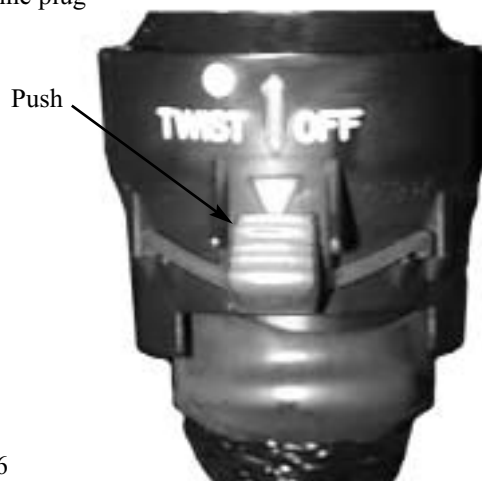

5

WIRING SCHEMATIC 5.2

Engine Electrical Wiring 250/255

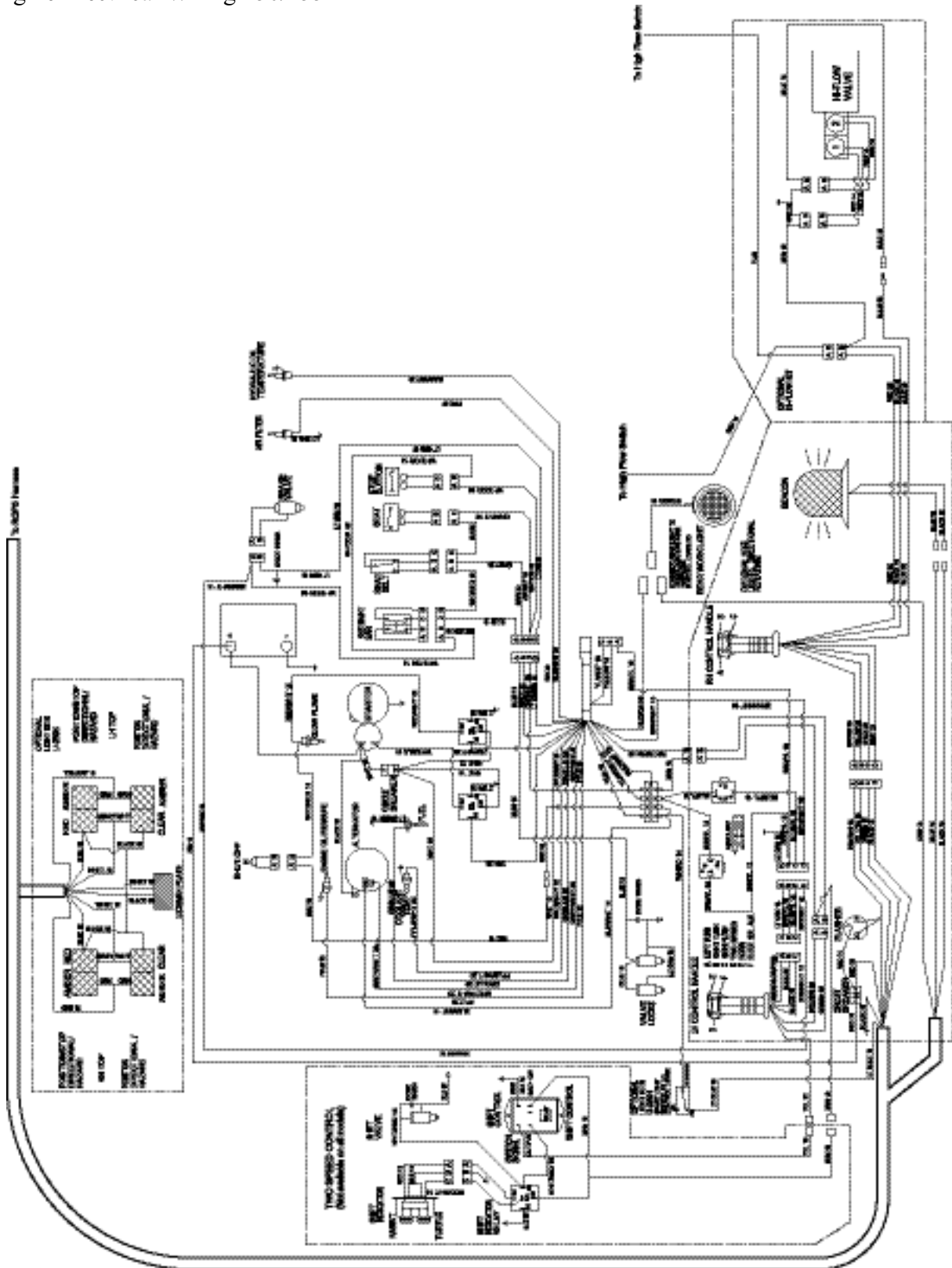

C3886

5

INSTRUMENTATION 5.3

Legend for fig. C3577

- 1 LH Turn Signal
- 2 Aux. Hydraulic Indicator
- 3 Hi-Flow Hydraulic Indicator
- 4 Headlight Indicator
- 5 RH Turn Signal
- 6 Hyd. Oil Temperature Indicator
- 7 Parking Brake Indicator
- 8 Seat Belt Indicator
- 9 Hyd. Charge Pressure Indicator
- 10 Strobe Light Indicator
- 11 Engine Oil Pressure
- 12 Engine Coolant Temperature
- 13 Alternator Indicator
- 14 Air Filter Restriction Indicator
- 15 Engine Preheat Indicator
- 16 Headlight Switch
- 17 Strobe Light Switch
- 18 Four Way Flasher Switch
- 19 Work light Switch
- 20 Aux. Hydraulics Switch
- 21 Hi-Flow Hydraulic Switch
- 22 Spare Switch Hole
- 23 Spare Switch Hole

Switch & Bulb Replacement

To replace a malfunctioning switch or indicator light:

- 1 Remove the 3 screws retaining the electrical panel to the dash pod. (fig. C3577, C3578)
- 2 Disconnect the spade terminals on the rear of the switch. (fig. C3578)
- 3 Remove the switch by loosening the hex nut on the back, then unscrewing the knurled nut on the front of the electrical panel.
- 4 Replace an indicator bulb by turning out the socket and pull bulb out.
- 5 Replace the switch, indicator light and panel in the reverse order.

If the dash pod is damaged, remove the 2 mounting bolts and slip over the dash panel. (fig. C3579)

Disconnect all panel wiring if replacing the complete unit. Replace the parts in reverse order. Follow the wiring schematic to properly locate the switches and wiring in position.

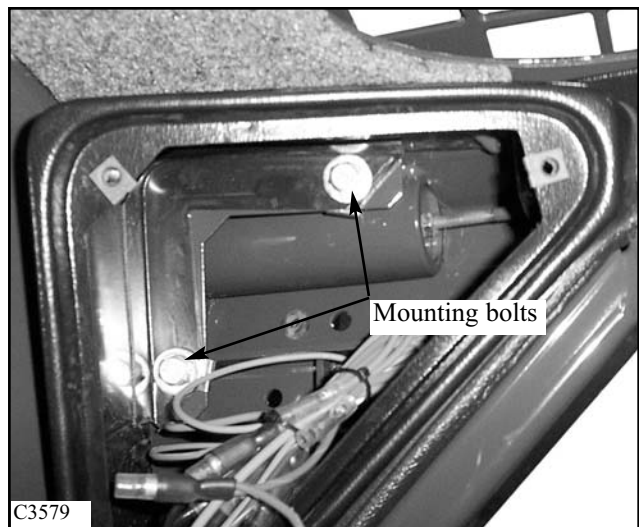
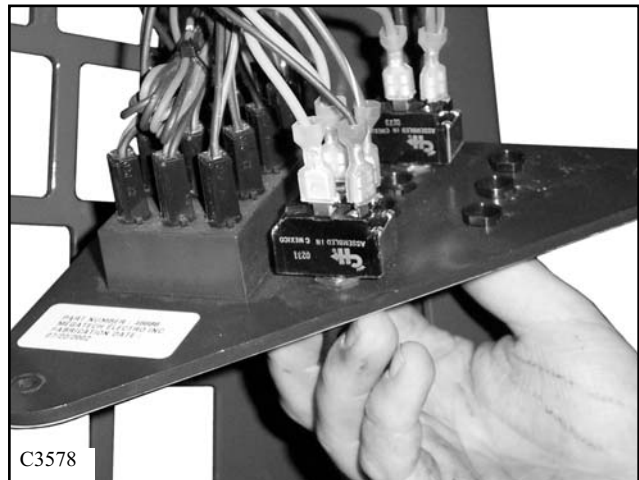
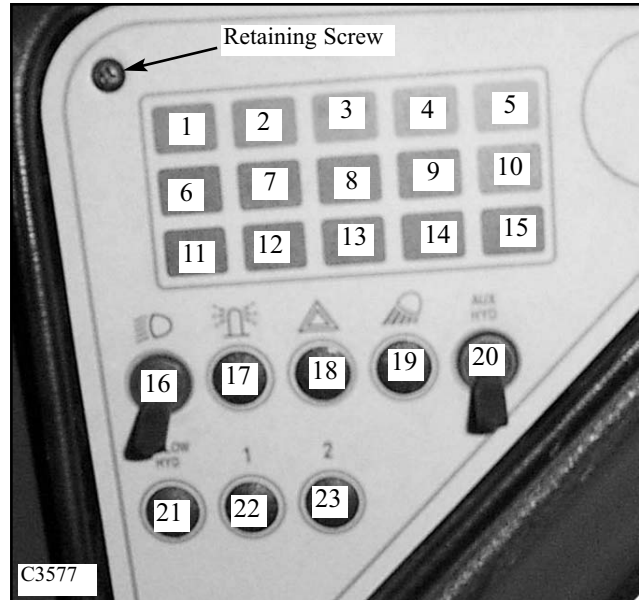

5

INSTRUMENTATION 5.3

Replacement

To replace a faulty gauge, meter or switch in the right hand dash panel:

- 1 Disconnect the battery cable connection.
- 2 Remove the 3 screws retaining the dash panel to the dash pod. (fig. C3580)
- 3 Access the rear of the dash panel.
- 4 Remove the wiring from the effected part.
- 5 The fuel gauge is retained by a bracket and 2 mounting nuts. Remove the nuts and the gauge can be replaced.
- 6 The ignition switch is retained by the knurled nut on the outside of the dash panel. Remove the nut and the switch can be replaced.
- 7 The hour meter is retained in the dash panel with molded in tabs. Pull the tabs outward and the hour meter can be replaced.

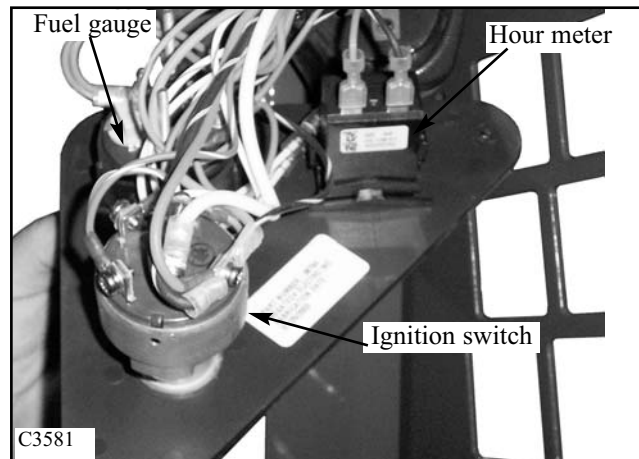
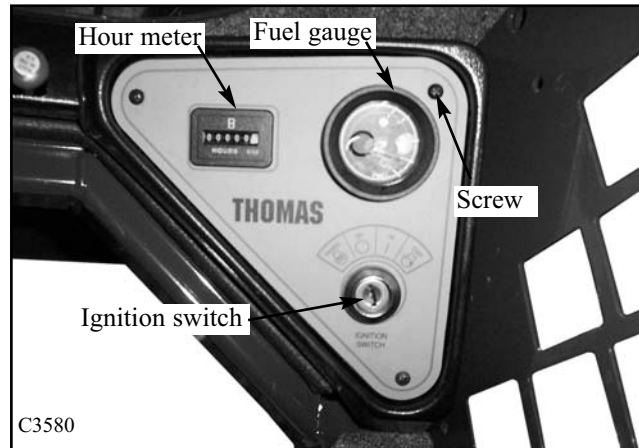

Testing the Fuel Gauge

- 1 Remove the right hand dash panel to access the gauge. (fig. C3581)

- 2 With the ignition switch off, connect an ohmmeter between the “S” terminal and the “P” terminal. (fig. C307)
 - 3 An ohmmeter reading of 150 to 250 ohms is normal. A higher or lower reading means the gauge is faulty and needs to be replaced.
- NOTE: If the fuel gauge test results were good and the gauge still fails to function do the following test.

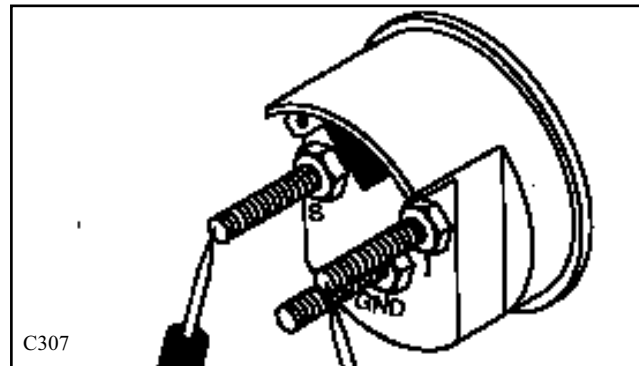

- 1 With the ignition switch off, connect an ohmmeter between the “S” terminal and the other end to ground.
 - 2 An ohmmeter reading of 50 to 500 ohms is normal. A higher or lower reading means the wire going to the “S” terminal is faulty.
- NOTE: If the test is good, check the fuel sending unit in the fuel tank for failure.

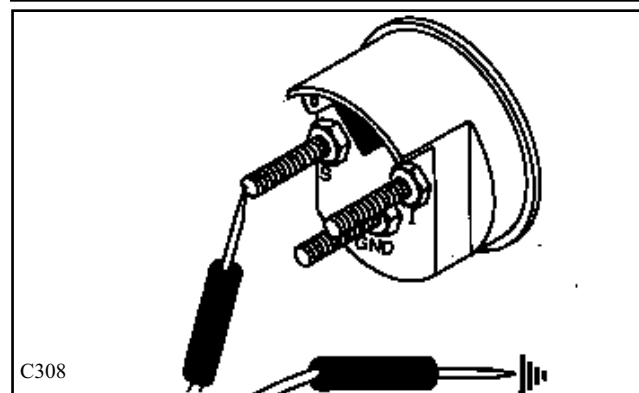

5

INSTRUMENTATION 5.3

Testing the Fuel Sender

- 1 With the ignition switch off, connect an ohmmeter between the positive and negative terminals of the fuel sending unit. (fig. C306)
- 2 An ohmmeter reading of 50 to 500 is normal. A reading higher or lower means a faulty sender and will need replaced.

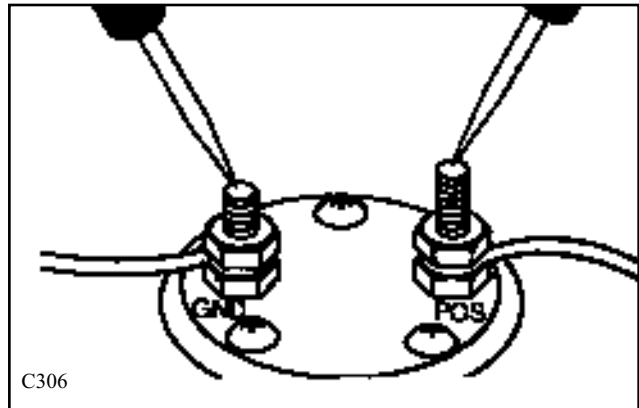

Replacement

- 1 Remove any attachment, raise the boom arms and engage the boom support pins. Shut off the engine and engage the parking brake.
- 2 Remove the 2 wires connected to the fuel sending unit. The fuel sender is located just below the lift cylinder, right hand side, on the fuel tank.
- 3 Remove the 5 screws retaining the sender to the fuel tank.
- 4 Remove the sending unit and discard the gasket.
- 5 Install a new sending unit and gasket. Use gasket sealant on both sides of the gasket.
- 6 Use thread sealant on the screws and torque the screws to 20 inch / lbs. (fig. C3582)
- 7 Connect the sender wires taking care not to over tighten the nuts and stripping the studs. Green wire is ground.

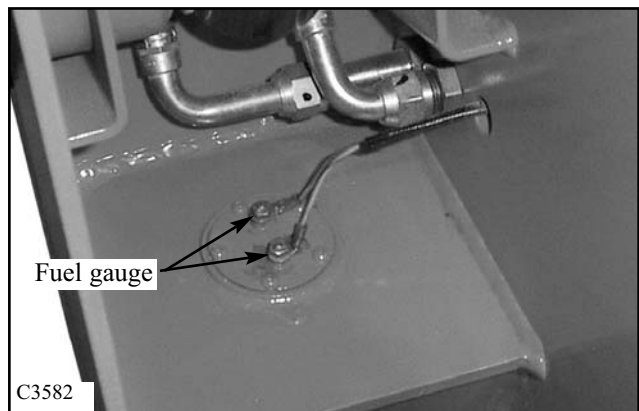

Testing the Hour Meter

The hour meter records the number of engine operating hours.

To check the hour meter, remove the 3 screws retaining the right hand dash panel to the dash pod. (fig. C3580, C3581)

Using a 12 volt test meter, connect the positive lead to the positive terminal of the hour meter and the ground lead of the tester to a good ground. Turn the ignition switch to the "RUN" position.

A reading of 12 volts means the hour meter is operating properly.

No voltage reading means there could be a problem in the wire running from the "ACC" terminal on the ignition switch to the positive side of the hour meter or a defective ignition switch.

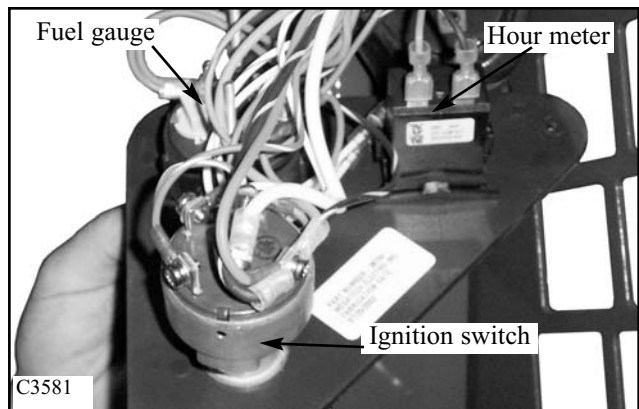
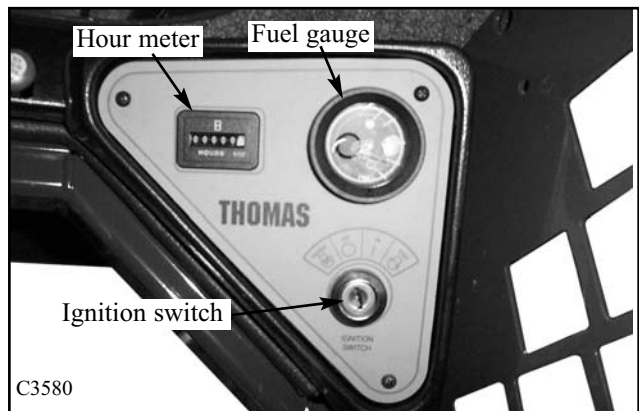

IGNITION SWITCH 5.4

Ignition Switch Testing

The ignition switch is a 4 position switch. OFF, PRE-HEAT, RUN and START. Turning the key counterclockwise will engage the PREHEAT. To activate the starter, turn the key clockwise. When the key is released it will return to the RUN position.

Before performing any test to the ignition switch, disconnect the negative or ground wire from the battery terminal. Remove the 3 screws retaining the right hand dash panel to the dash pod to access the ignition switch.

TEST 1: "RUN" POSITION.

Connect an ohmmeter across the terminals marked 30 and ACC. (fig. C297) Turn the ignition switch to the run position.

A low resistance reading is normal. High resistance reading means you will have to replace the ignition switch.

TEST 2: "START" POSITION.

(a) Connect an ohmmeter between the terminals marked 30 and 50 on the ignition switch. (fig. C298) Turn the ignition switch to the "START" position and observe the ohm readings.

(b) Connect the ohmmeter leads across terminals marked 30 and 17 on the ignition switch. (fig. C299) Turn the ignition switch to the "START" position and observe the ohmmeter reading.

Low resistance reading is normal.

High resistance reading means the ignition switch needs replacement.

TEST 3: "HEAT" POSITION.

Connect the ohmmeter leads between the terminals marked 30 and 19 on the ignition switch. (fig. C300) Turn the ignition switch to the "HEAT" position and observe the ohmmeter readings.

Low resistance reading normal.

High resistance reading, replace the ignition switch.

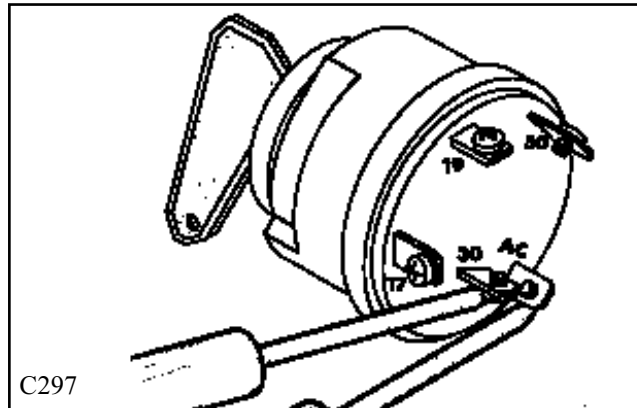

C297

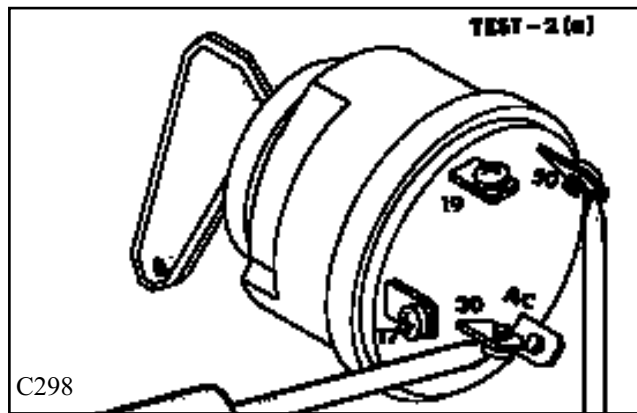

C298

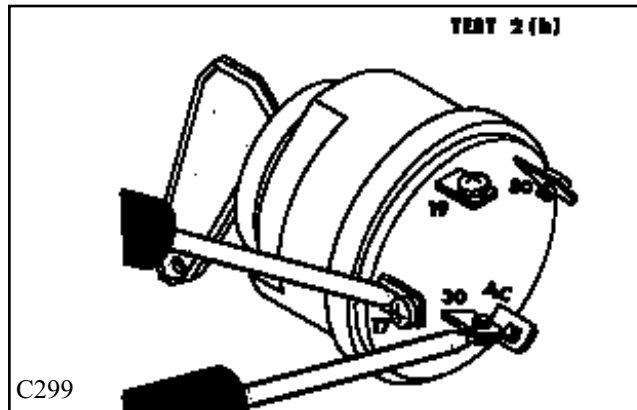

C299

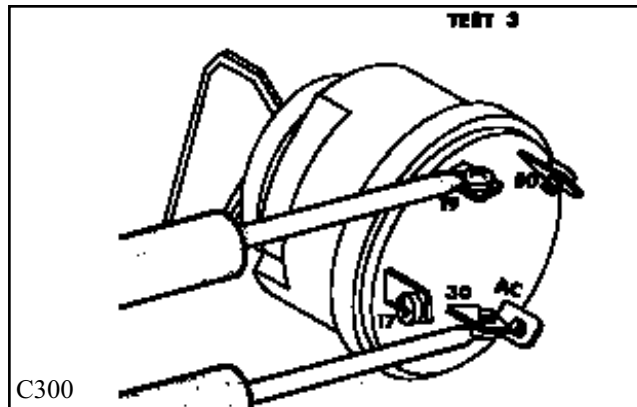

C300

5

ENGINE GLOW PLUGS 5.5

Testing the Glow Plugs

Before performing any test on the glow plugs, disconnect the ground wire from the battery.

TEST 1: GLOW PLUGS.

With the ignition switch off, connect one end of the ohmmeter lead to the manifold heater terminal and the other lead end to a clean ground.

A reading of 1.5 ohms is normal.

An infinite or 0 reading means the heater is defective.

TEST 2: IGNITION SWITCH to GLOW PLUGS.

Remove the 3 screws retaining the right hand dash panel to the dash pod. (fig. C3580, C3581) With the ignition switch off, disconnect the red / white wire from ignition terminal 19. Connect one ohmmeter lead to the terminal marked 19 on the ignition switch and the other lead to the red / white wire.

Low to 0 reading means good continuity.

High reading means the red / white wire from the ignition switch to the manifold heater is defective.

TEST 3 IGNITION SWITCH "HEAT" POSITION.

Connect the ohmmeter leads between the terminals marked 30 and 19 on the ignition switch. (fig. C300) Turn the ignition switch to the "HEAT" position and observe the ohmmeter readings.

Low resistance reading normal.

High resistance reading, replace the ignition switch.

Pre-Heat Indicator

Check the ignition switch terminals 17 and 19 with an ohmmeter. If there is good continuity between the two terminals the bulb or wiring is bad on the pre-heat indicator light.

To change the indicator bulb, remove the 3 screws retaining the left hand dash panel to the dash pod. Select the proper bulb, twist and pull the bulb from the dash panel. Disconnect the wires and replace the bulb in reverse order.

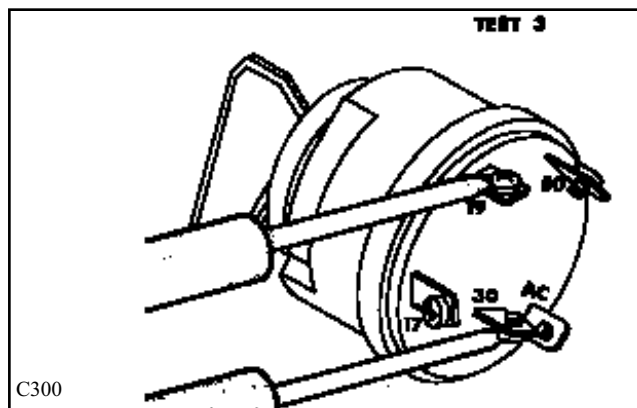
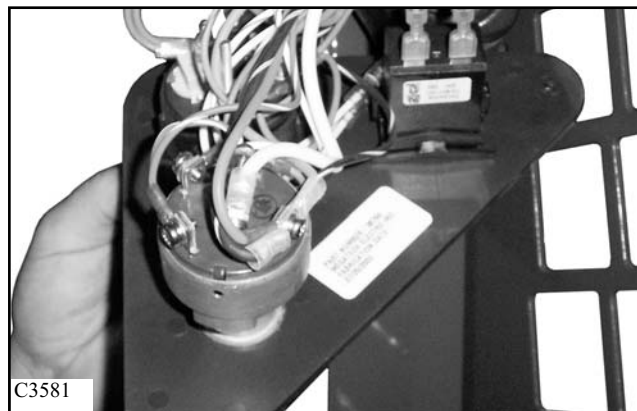
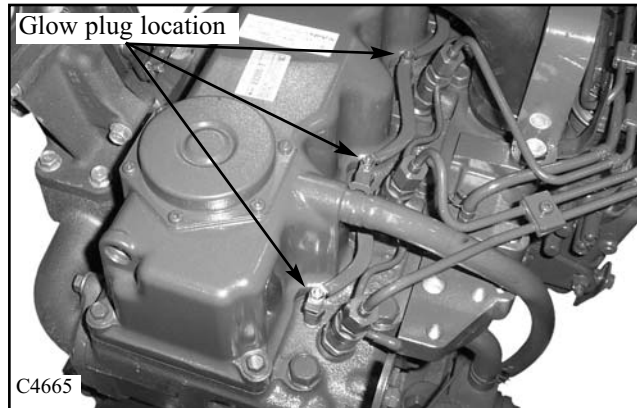

BATTERY 5.6

Removal and Inspection

The batteries are located in the ROPS behind the operator's seat. To remove the battery:

- 1 Remove the seat mount retaining bolts and disconnect the seat switch wiring harness. (fig. C3557)
- 2 Pull up and toward the front of the loader and remove the seat. Be careful to not catch any electrical wiring while removing.

- 3 Remove the access bolt from the battery compartment cover. (fig. C3583)

 **WARNING**

Batteries contain sulfuric acid which can harm the eyes and skin on contact. Always wear goggles and protective clothing while servicing the battery. Flush skin or eyes with water upon contact. Consult a physician.

- 4 Raise the battery compartment cover and latch the prop bar in place. (fig. C3584)
- 5 Disconnect both battery ground terminals first. Then disconnect the positive cables from the battery. (fig. C4666)
- 6 Remove the bolt securing the battery hold down bracket. (fig. C4667)
- 7 Carefully remove the battery from the compartment.
- 8 Inspect the battery cables for corrosion and damage. Remove any corrosion using a wire brush and a soda solution. Replace the cables having damaged or deformed ends.
- 9 Clean the outside of the battery case if the battery is to be reused. Flush the terminal areas with a soda solution taking care not to allow the solution into the battery cells. Remove corrosion from the battery terminals with a wire brush..

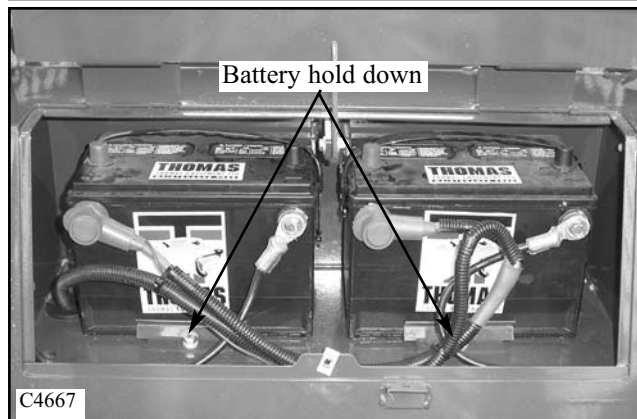
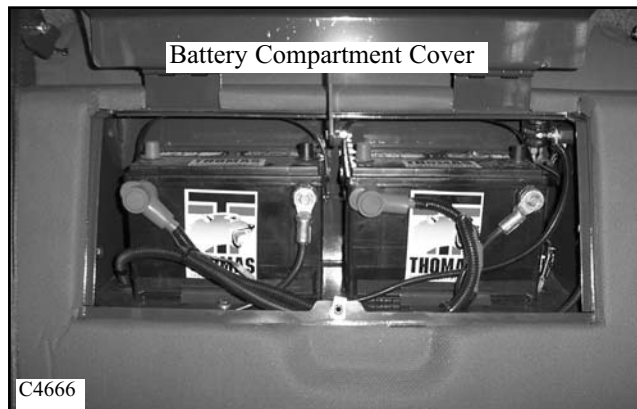
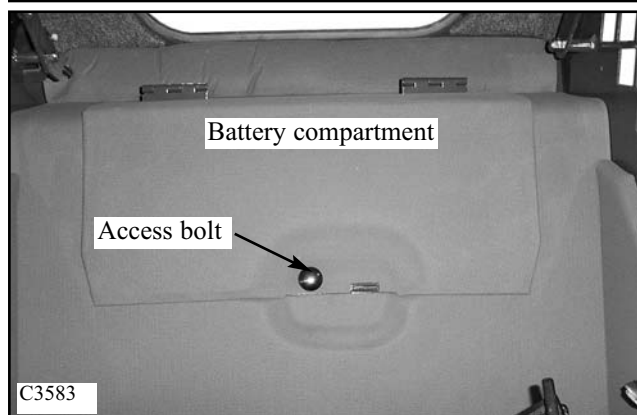
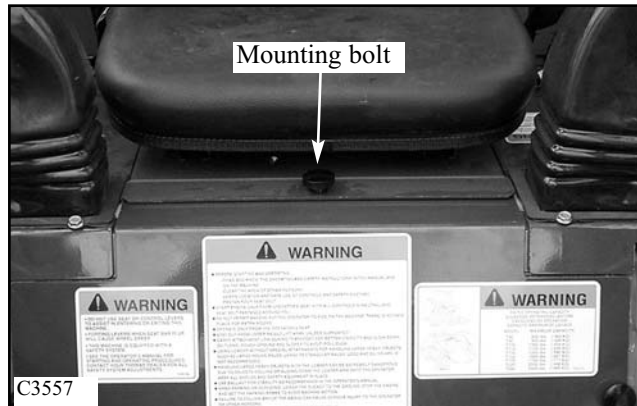

BATTERY 5.6

Removal and Inspection

10 Inspect the battery case for cracks that may allow electrolyte to leak into the environment. Inspect the batteries on a regular basis for damage such as cracks or a broken case. Inspect the battery cables for tightness and corrosion. Remove any corrosion and coat the terminals with a dielectric grease. Check the battery hold downs to be sure they are properly retaining the battery in the compartment. (fig. C4667)

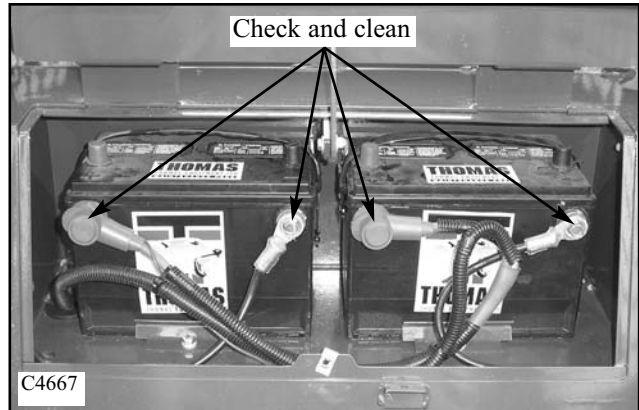

Boosting

In the event the loader has failed to start and requires boosting, a boosting lug or post is located in the engine compartment. (fig. C4601)

- 1 Open the rear door and raise the engine compartment cover.
- 2 Remove the red rubber protective cover from the boosting lug. (fig. C4668)
- 3 The ignition must be in the off position.
- 4 Connect the positive cable from the 12 volt boosting supply to the boosting lug on the loader.
- 5 Connect the negative ground cable to the boosting supply first, and then to a clean ground on the loader engine. Keep the cables away from any moving parts.
- 6 Start the engine.
- 7 Remove the negative ground cable from the engine first and then the boosting supply. Remove the positive cable from the boosting lug.

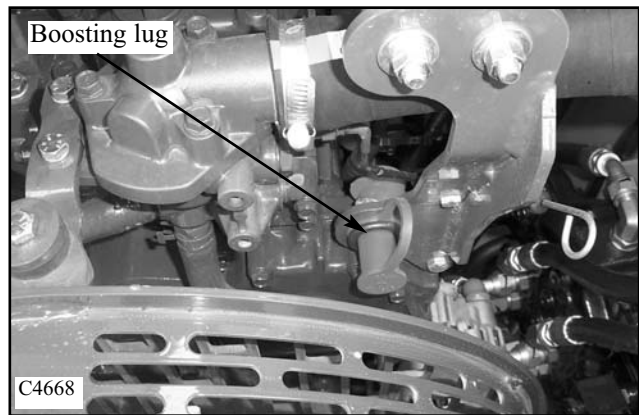
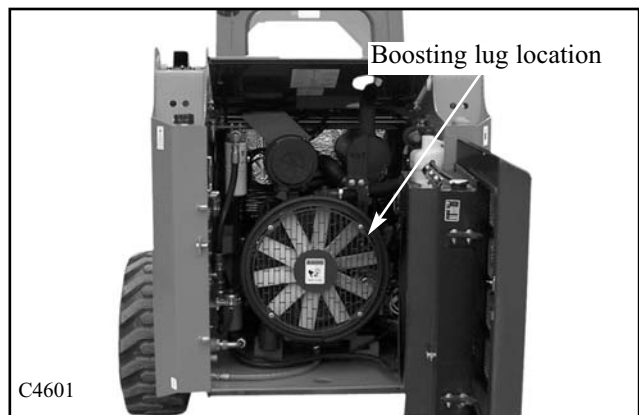

Circuit Breaker

The circuit breaker is located in the engine harness, right hand side of engine. (fig. C4669) The circuit breaker is covered by loom and is not immediately visible to the eye.

- 1 Disconnect the battery grounds before testing or replacing the circuit breaker.
- 2 Strip the loom covering back to access the circuit breaker.
- 3 Remove the 2 nuts retaining the wires to the circuit breaker.
- 4 Using an ohmmeter, connect a lead to each of the stud terminals and take a reading. Low resistance is normal. High resistance means the circuit breaker is defective and must be replaced.

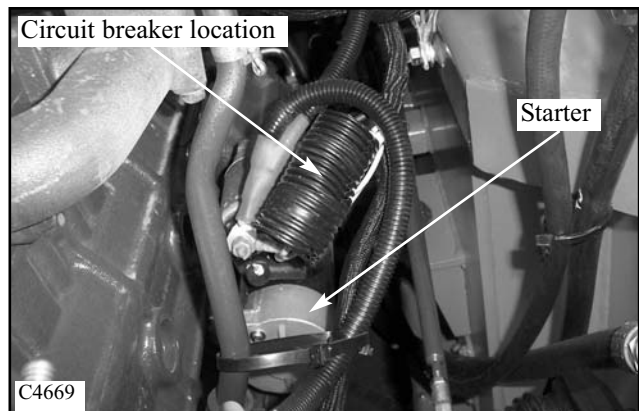

5

ELECTRICAL PANEL 5.7

The loader is equipped with a 12 volt, negative ground electrical system. The fuse and relay panels are located in the engine compartment, attached to the underneath of the engine cover. (fig. C3588)

To access the electrical panel:

- 1 Open the rear door and raise the engine cover.
- 2 Remove the bolt holding the electrical panel cover closed. (fig. C3588)
- 3 Open the cover and all fuses and relays will be exposed. (fig. C3589)

Visually check the fuses for burnt contacts.

The relays are identical and may be checked by swapping one for the other to trace a malfunction. If changing the relays around does not repair the problem, the problem is somewhere else.

The ground bolt should be checked occasionally for corrosion and cleaned if necessary. Use a dielectric grease to protect the ground point from the elements.

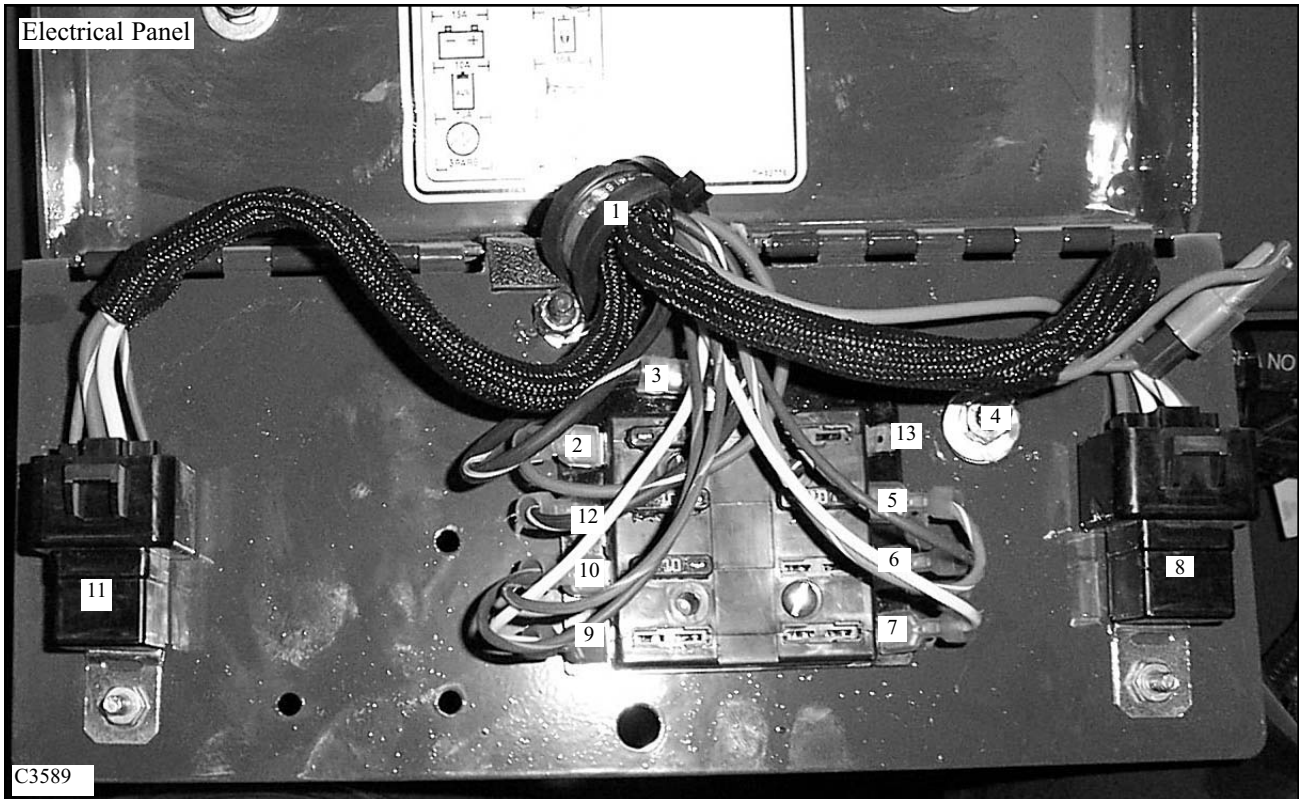
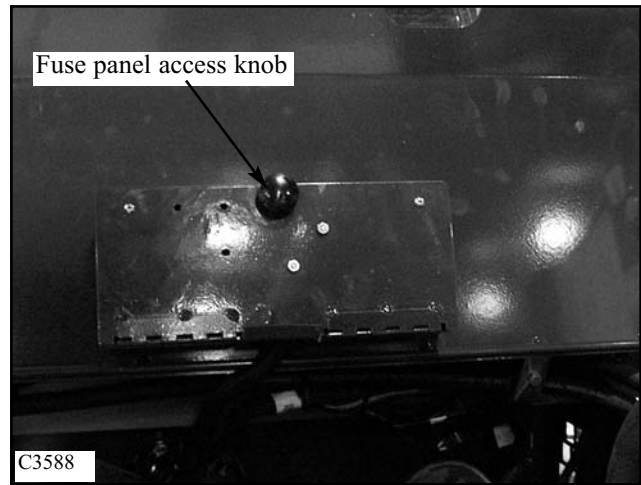

ELECTRICAL PANEL LEGEND.(fig. C2052)

- | | |
|---|--|
| 1 Engine harness | 7 Option (10Amp, YL / WH) |
| 2 Engine Shut Off (15 Amp, RED) | 8 Starter Relay (40 Amp) |
| 3 Power Inlet From Ignition Switch Acc (BLK / WH) | -9 Option (10 Amp YL) |
| 4 Grounding Point (LT GRN) | 10 Auxiliary Solenoid (10 Amp, RED / YL) |
| 5 Safety Switches (15 Amp, OR / WH) | 11 Manifold Heater Relay (40 Amp) |
| 6 Horn / Two Speed Option (10 Amp, BRN) | 12 Alternator (10Amp, BLK / WH) |
| | 13 Option (10Amp) |

5

STARTING CIRCUIT 5.8

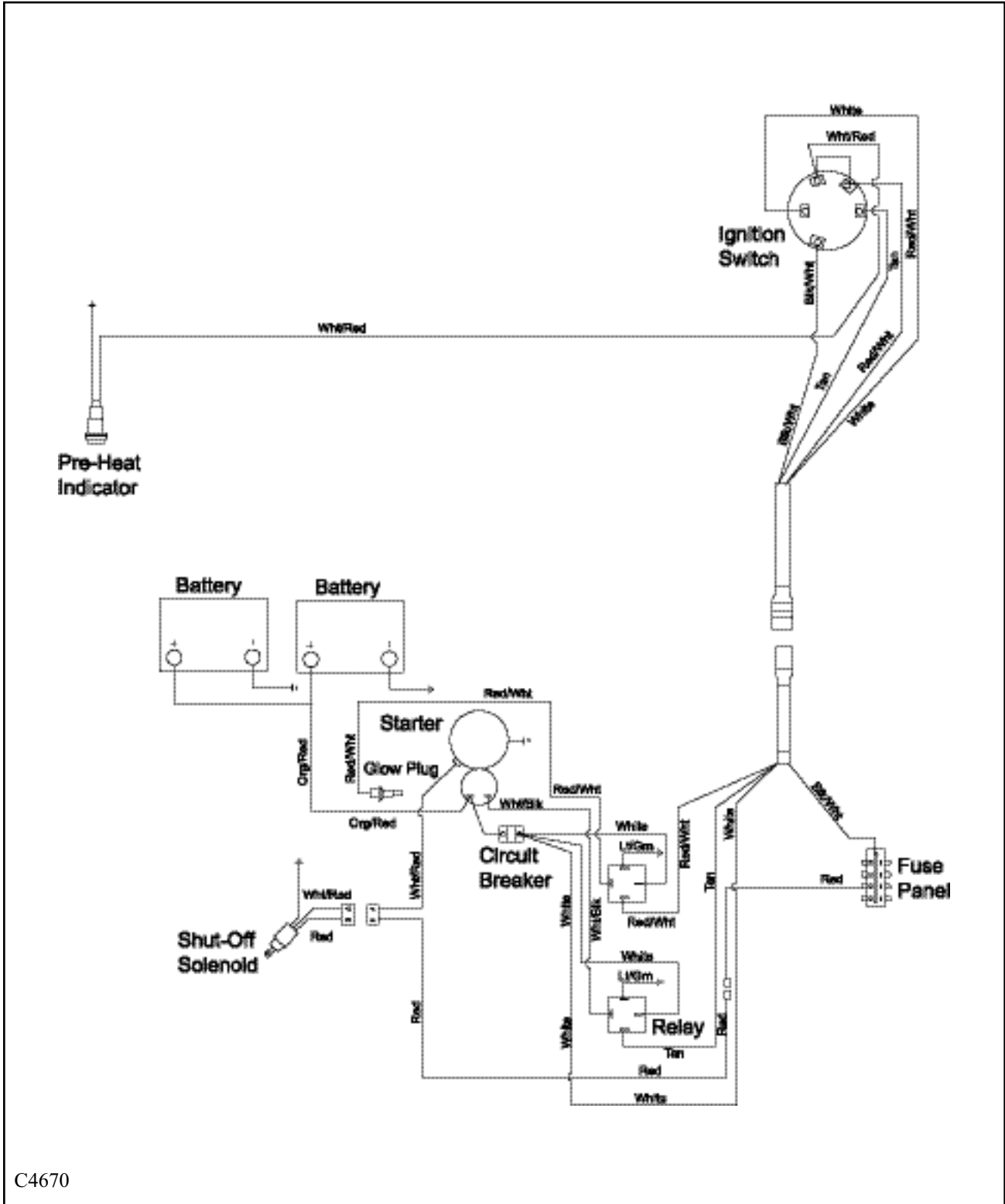

C4670

5

CHARGING CIRCUIT 5.9

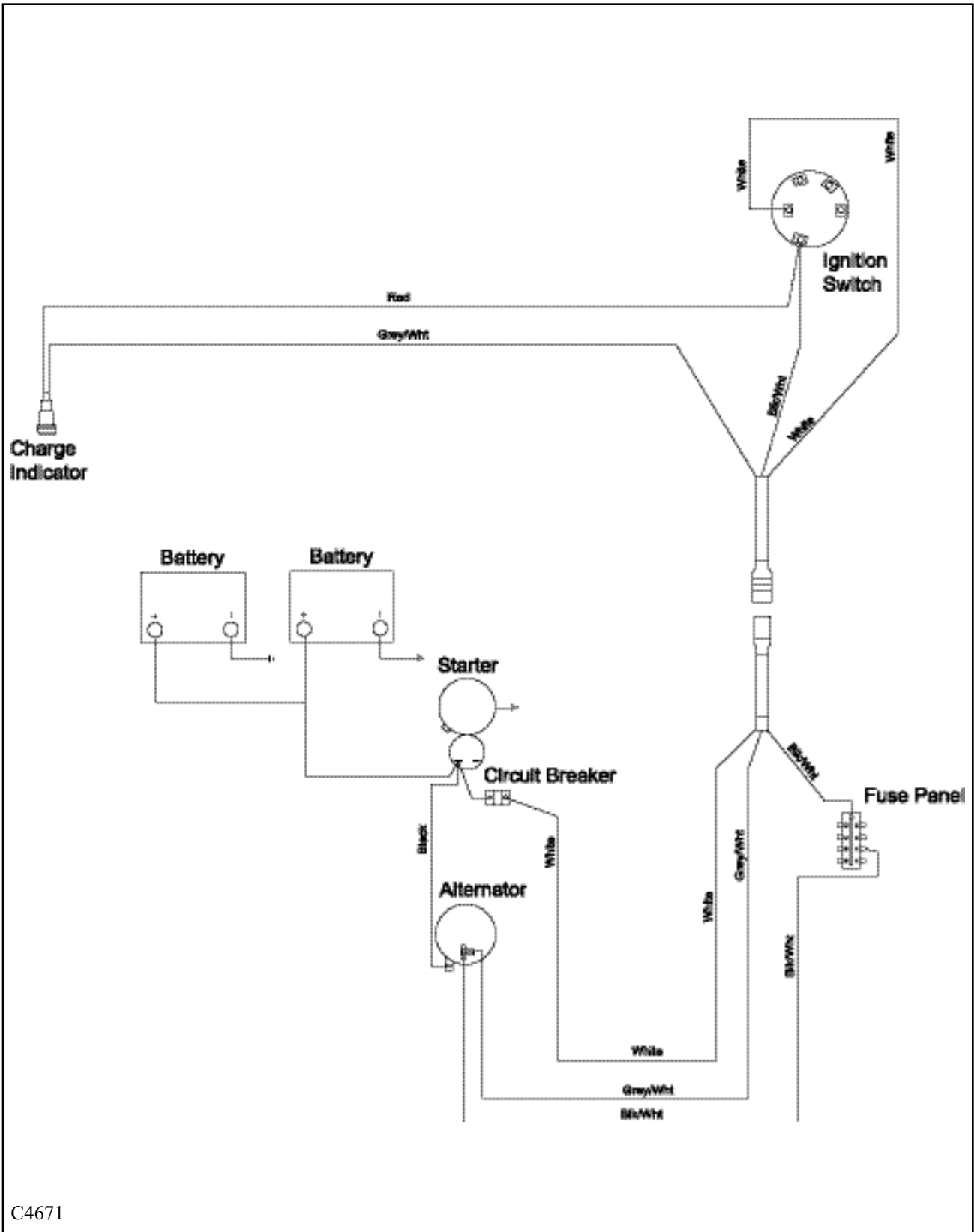

C4671

SAFETY CIRCUIT 5.10

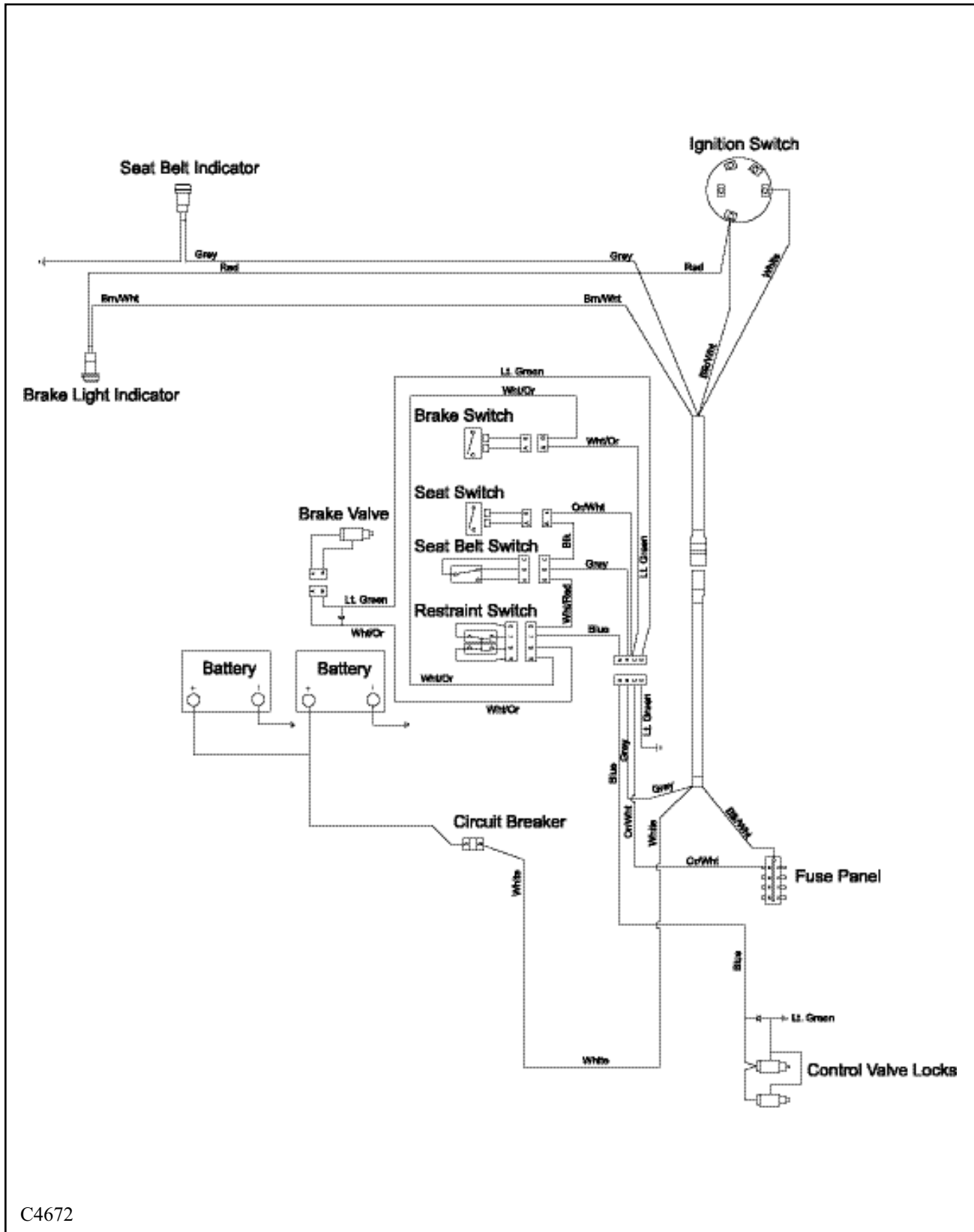

C4672

SAFETY CIRCUIT 5.10

General Information

The loader is equipped with 3 inter - connected safety switches. These 3 switches operate 2 electric solenoid controlled lock devices. One (1) solenoid coil on the hydraulic brake valve (fig. C3575), one (1) pair of solenoid coils on the hydraulic control valve (fig. C1514) The operation of the solenoid coils and loader functions will be prevented if one of these safety switches are open. All 3 must be hooked up, functioning and if applicable, adjusted correctly.

The bottom of the operators seat is equipped with a pressure sensitive switch. The operator must be in the seat to close the switch and release the parking brake and unlock the control valve functions. (fig. C807) No adjustments required. When removing and replacing the seat, be sure not to pinch the wires under the seat plate.

The seat belt assembly is equipped with a safety switch. The operator must have the seat belt fastened around them in order to close the switch and allow the parking brake to release and the control valve to function. (fig. C3879) No adjustments required.

The restraint bar is equipped with a dual function safety switch. (fig. C3573) With the restraint bar in the raised position, the parking brake is activated, the control valve functions are locked and the activation indicator lights are illuminated on the dash panel.

Lowering the restraint bar releases the parking brake, turns off the indicator lights in the dash panel and releases the locks in the control valve.

The restraint bar must be in the lowered position for the control functions to operate.

The switch must contact the restraint bar when in the lowered position.

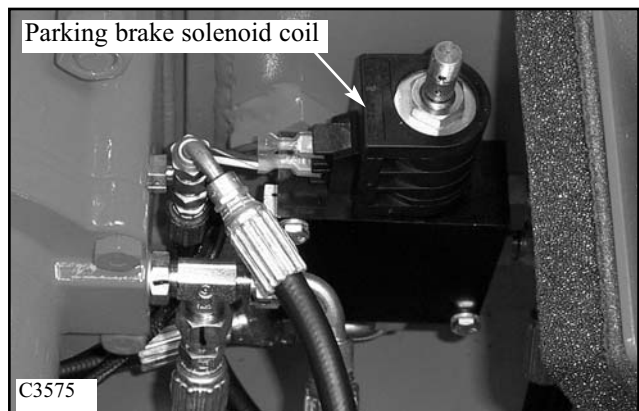
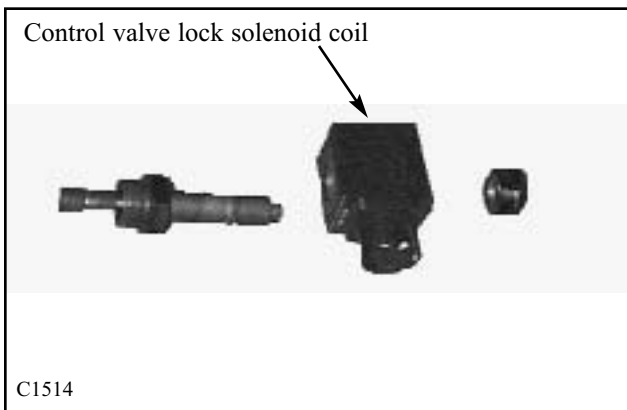
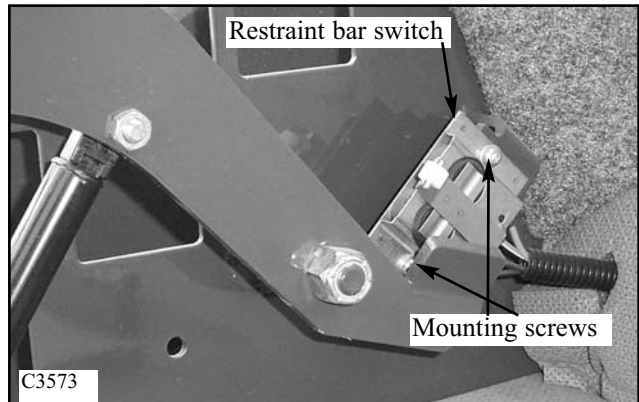
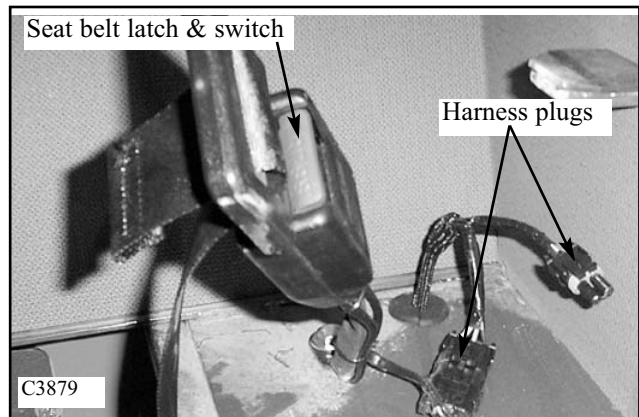
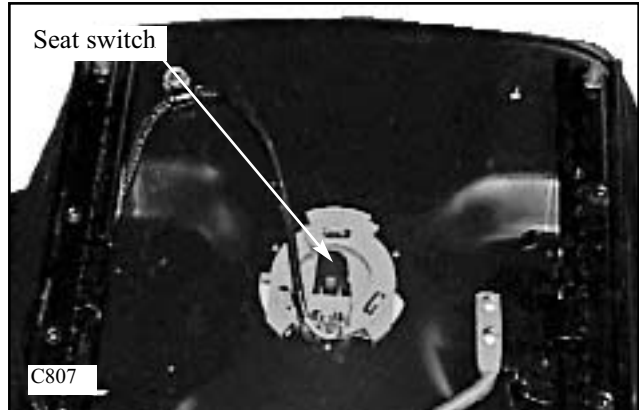

5

— ELECTRIC AUXILIARY CIRCUIT 5.11 —

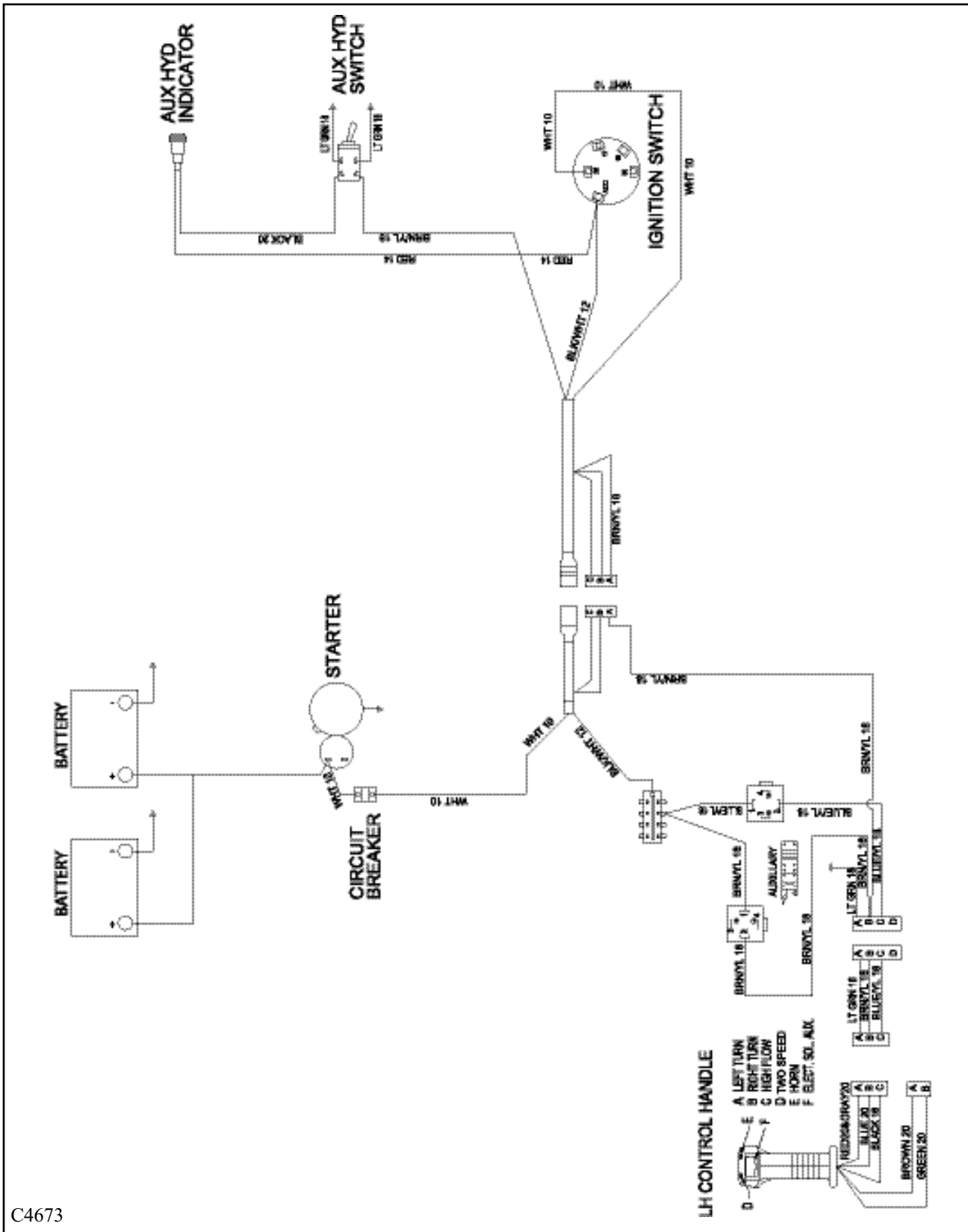

C4673

—ELECTRIC AUXILIARY CIRCUIT 5.11—

THE ERGONOMIC HANDLE CONTROL:

The Ergonomic Handle contains 3 switches: 1 rocker switch (fig. C3861) and 2 push button switches. (fig. 3860)

The handle is normally installed only on the left hand control lever for the loader.

When installed on the L.H. lever:

1. The rocker switch controls the electric aux. functions. Pushing down on the left side of the rocker switch is the forward direction and pushing down on the right side is the reverse direction.
2. L.H. push button is a spare to be used if adding an option.
3. R.H. push button is for the horn.

When installed on the R.H. lever:

1. The rocker switch is used to control the Hi-Flo option. Pushing down on the left side of the rocker switch is the forward direction and pushing down on the right side of the rocker switch is the reverse direction.
2. The L.H. and R.H. buttons are used to turn the signal lights on when the light kit option is installed.

To replace a defective switch:

1. Ensure the ignition switch is in the OFF position.
2. Remove the 4 screws that hold the 2 handle pieces together. (fig. C3862)
3. Remove the L.H. handle piece and pull the switch/wire assembly out of the R.H. handle piece.
4. The original rocker switch has the wires soldered to the terminals of the switch. Take note of the wire color attached to each terminal before removing the wires.
5. The rocker switch has a tab on each end of the switch which needs to be depressed before removing the switch.
6. The rubber rocker cover can be replaced or reused on the replacement rocker switch at this time.
7. Replace the switch and reattach the wires. Proper female spade terminals may be soldered to the wires.

After servicing the control handle be sure the hydraulic flow is circulating in the proper direction. Pushing on the L.H. side of the switch should engage the hydraulic system in the forward direction. The female quick coupling must always be the power out when engaging the control mounted switch in this direction.

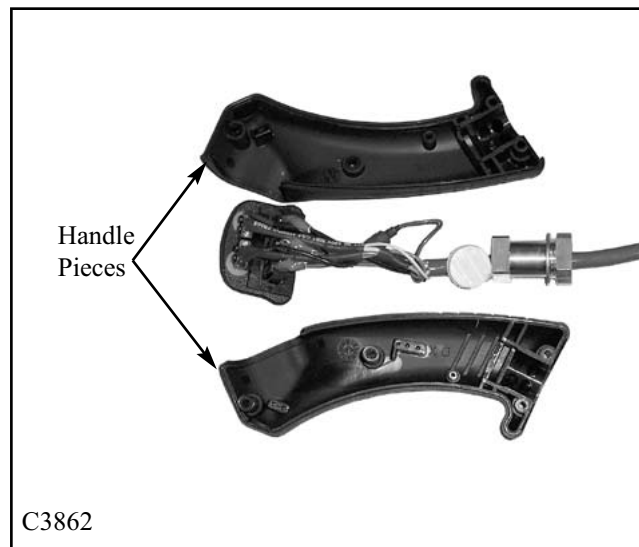
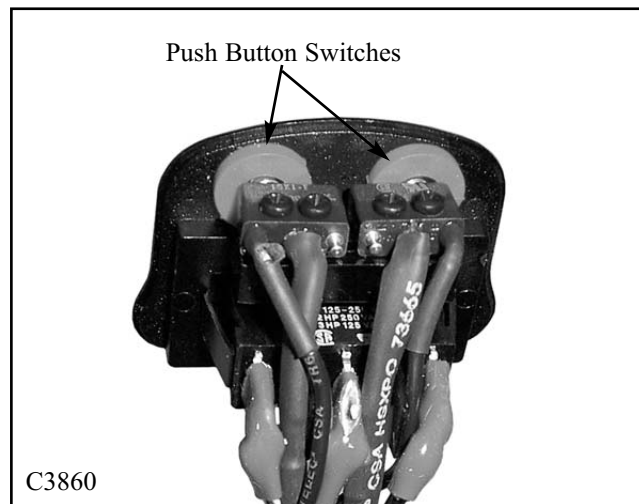
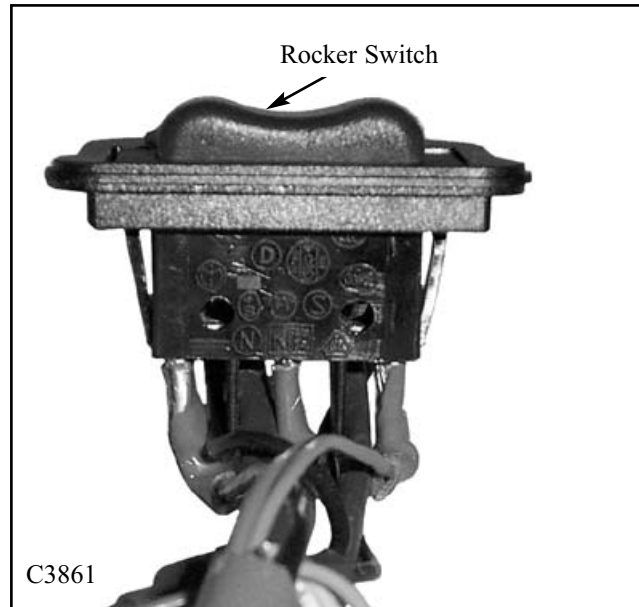

TWO SPEED OPTION 5.12

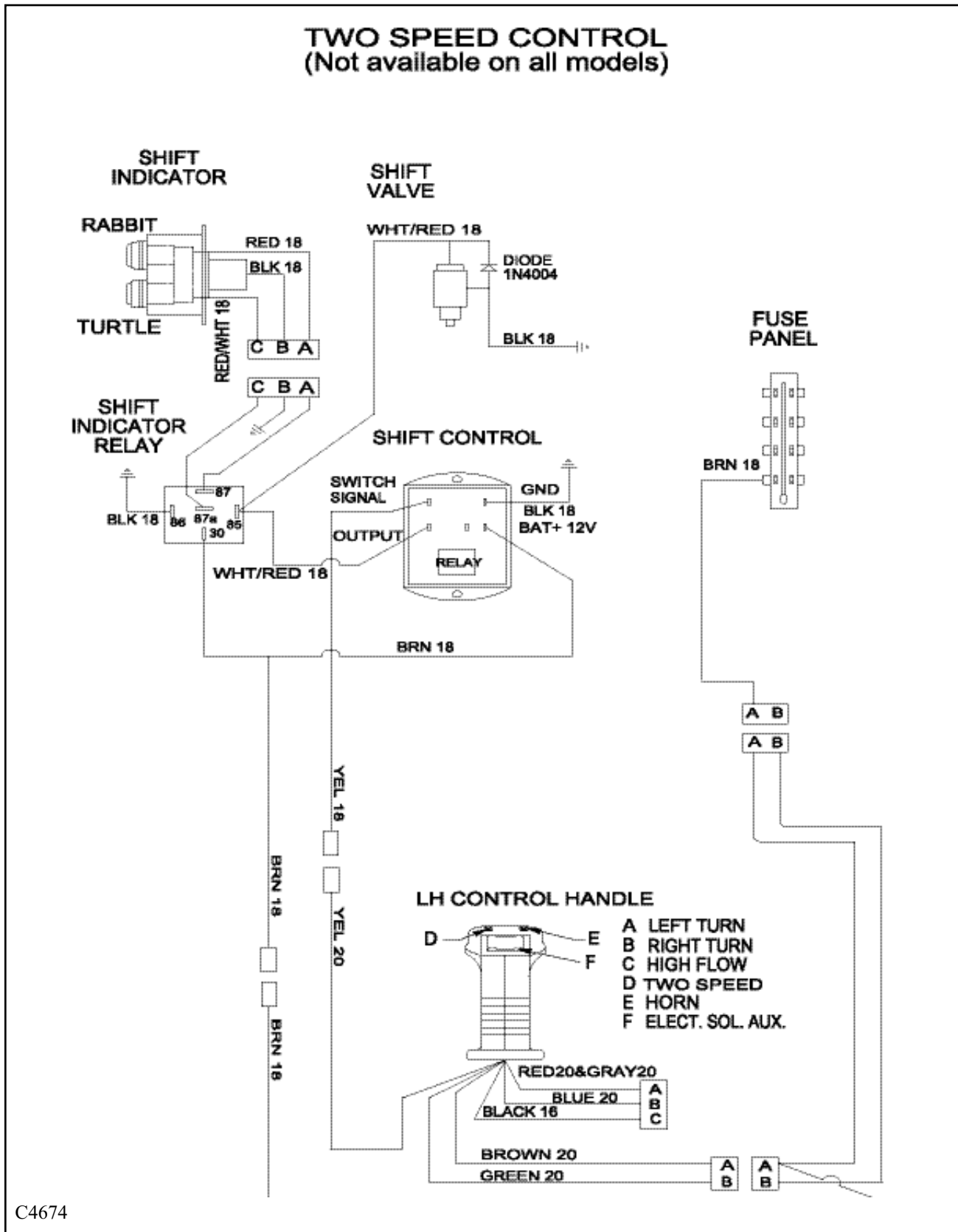

5

TWO SPEED OPTION 5.12

General Information

Some models of the 255 can operate in 2 different speeds. The radial piston motor has an option where a two speed valve reduces the motor displacement by halve. This means that during the working stroke, only half the pistons are supplied with fluid. When the valve is connected, The motor will run at twice the speed but half the torque.

A switch located on the LH steering control lever (Fig. C3015) is used to alternately activate the loader's Two-Speed function. Pressing and releasing the switch will activate the Hi-speed function. Pressing and releasing the switch a second time will return the loader to the Low-speed function.

When the loader ignition is turned to the "OFF" position, the Two-Speed control returns to the Low-speed function.

An indicator panel is mounted on the LH ROPS post (Fig. C3907) to show the operator which function is activated at any given time. For proper loader operation, always select the loader speed function which is best suitable for the existing work environment.

Refer to fig. C4674 page 5-21. The way the electric circuit works is that the brown wire in the fuse box provides power to the circuit. When the LH control handle is pressed, it provides power to the shift control relay via the yellow wire to the switch signal. The shift control relay is then activated, the output is then supplied with power. The output terminal is connected to 2 different circuits, the shift indicator and the shift valve.

In the shift indicator circuit, the turtle light is connected to the normally closed terminal of the shift indicator relay. (fig. C4690) It is supplied with power from the brown wire (Bat +12V). When the handle switch is pressed, power is applied to the output terminal of the shift control. The shift indicator relay is switched and power is applied to the rabbit light. When the ignition key is turned off the circuit is reset.

In the shift valve circuit, when the LH control handle is pressed, it provides power to the shift control relay via the yellow wire to the switch signal. The shift control relay is then activated, the output is then supplied with power. Power then is applied to the shift valve solenoid via the wht/red wire. This activated the coil and hydraulic fluid is then passed through the shift valve the into the 2 speed port of the torque motor. (fig. C4691) This activates the 2 speed valve inside the torque motor. The torque motor then switched to half displacement. The diode in the circuit provide overload protection on the solenoid coil.

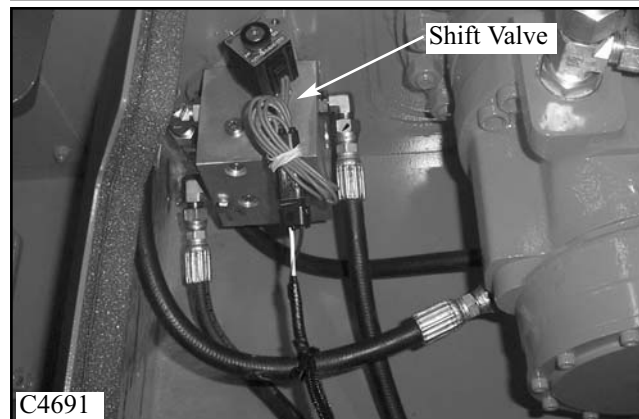
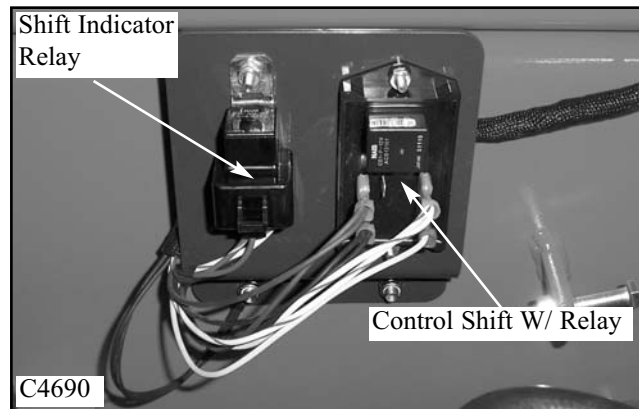
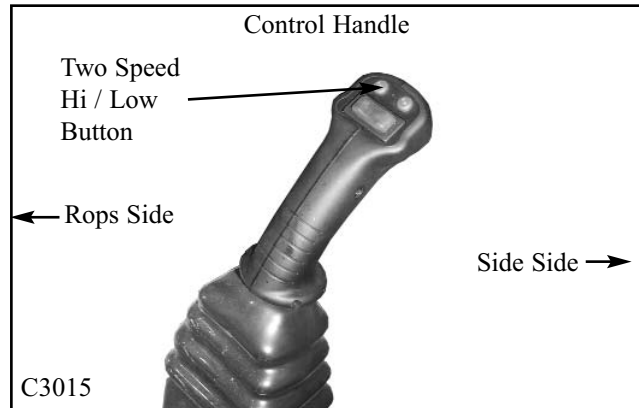

5

TROUBLE SHOOTING 5.13

STARTING SYSTEM

Problem	Cause	Corrective Action	Section
Starter will not engage.	Battery discharged.	Check the battery and charge or replace.	5.6
	Loose or disconnected wiring.	Verify continuity of starting circuit. Check and repair.	
	Defective ignition switch.	Check the switch and replace if necessary.	5.4
	Defective starter solenoid.	Check and replace if necessary. Kubota repair manual P / N 46577.	Kubota repair manual
	Defective relay.	Check and replace.	5.7
	Defective starter.	Check and replace if necessary.	Kubota repair manual
Starter motor turns but does not engage.	Defective overrunning clutch or low battery charge.	Replace starter or parts. Check the battery and charging system. Kubota repair manual P / N 46577.	Kubota repair manual
Pinion engages but engine does not turn over.	Defective starter.	Check and replace. Kubota repair manual P / N 46577.	Kubota repair manual
	Low battery charge.	Check and repair.	5.6
	Engine seizure.	Check and replace.	7
	Hydrostatic pump failure.	Check and replace.	2
Starter motor rotates a full speed before pinion engages.	Defective pinion spring.	Check and replace. Kubota repair manual P / N 46577.	Kubota repair manual
Starter remains engaged after the engine has started.	Faulty ignition switch.	Check and replace.	5.4
	Defective solenoid.	Check and replace. Kubota repair manual P / N 46577.	Kubota repair manual

5

SAFETY LOCKING MECHANISM

Problem	Cause	Corrective Action	Section
Control locks will not release.	Blown fuse.	Check fuse and replace with 15 Amp.	5.7
	Safety switch out of adjustment or defective.	Remove the seat, check and adjust or replace.	5.10
	Defective lock solenoid.	Check and replace.	2 / 5.10
	Defective lock mechanism.	Check and replace.	1.4 / 5.10
	Short in wiring harness.	Check for proper grounding, repair or replace harness.	

TROUBLE SHOOTING 5.13

CHARGING SYSTEM

Problem	Cause	Corrective Action	Section
Battery low in charge.	Faulty wiring or connections.	Check and repair or replace.	
	Drive belt slipping.	Check and adjust.	7
	Defective battery.	Test battery and replace if necessary.	5.6
	Defective alternator or regulator.	Check charging output. Repair or replace if necessary. (see Kubota manual Thomas p / n 46577)	Kubota repair manual
Alternator overcharging and battery overheats.	Defective battery.	Test battery and replace if necessary.	
	Defective regulator	Check charging output. Replace if necessary. (see Kubota repair manual Thomas p / n 46577)	Kubota repair manual
Low or no output voltage from alternator.	Drive belt slipping.	Check and adjust.	7
	Faulty wiring or connections.	Check and repair or replace.	
	Defective alternator or regulator.	Check charging output. Replace if necessary. (see Kubota repair manual Thomas p / n 46577)	Kubota repair manual
Charge indicator light flickers or runs dim.	Faulty wiring or connections.	Check and repair or replace.	
	Dirty alternator slip rings or brushes.	Check and repair or replace. (see Kubota repair manual Thomas p / n 46577)	Kubota repair manual
Charge indicator goes out but becomes brighter as the engine RPM increases.	Faulty wiring or connections.	Check and repair or replace.	
Charge indicator light is on while the engine is operating.	Drive belt slipping.	Check and adjust.	7
	Defective alternator or regulator.	Check charging output. Replace if necessary. (see Kubota repair manual Thomas p / n 46577)	Kubota repair manual

TWO SPEED OPTION

Problem	Cause	Corrective Action	Section
Torque motor will not shift (If equipped)	Blown fuse.	Check fuse on brown wire and replace with 10 Amp.	5-7
	Defective shift control	Remove the seat, repair or replace.	2
	Short in wiring harness.	Check for proper grounding, repair or replace harness.	
Shift indicator not working properly	Blown fuse.	Check fuse on brown wire and replace with 10 Amp.	5-7
	Blown bulb in indicator	Check light, repair or replace.	
	Defective shift indicator relay.	Remove the seat, repair or replace.	5-12
	Short in wiring harness.	Check for proper grounding, repair or replace harness.	



SECTION 6 MAIN FRAME

Quick - Tach	6.1
Illustration, Universal Type.....	pg. 6-2
Preventative Maintenance	pg. 6-3
Removal.....	pg. 6-4
Installation	pg. 6-4
Disassembly.....	pg. 6-5
Assembly.....	pg. 6-5
Boom Arms	6.2
Removal.....	pg. 6-6
Installation	pg. 6-6
Boom Support	6.3
Boom Arm Supports.....	pg. 6-7
ROPS (Cab)	6.4
Removal	pg. 6-8 ~ 9
Installation	pg. 6-9
Rear Door	6.5
Illustration.....	pg. 6-10
Removal.....	pg. 6-11
Installation	pg. 6-11



QUICK - TACH 6.1

Universal Quick - Tach Assembly

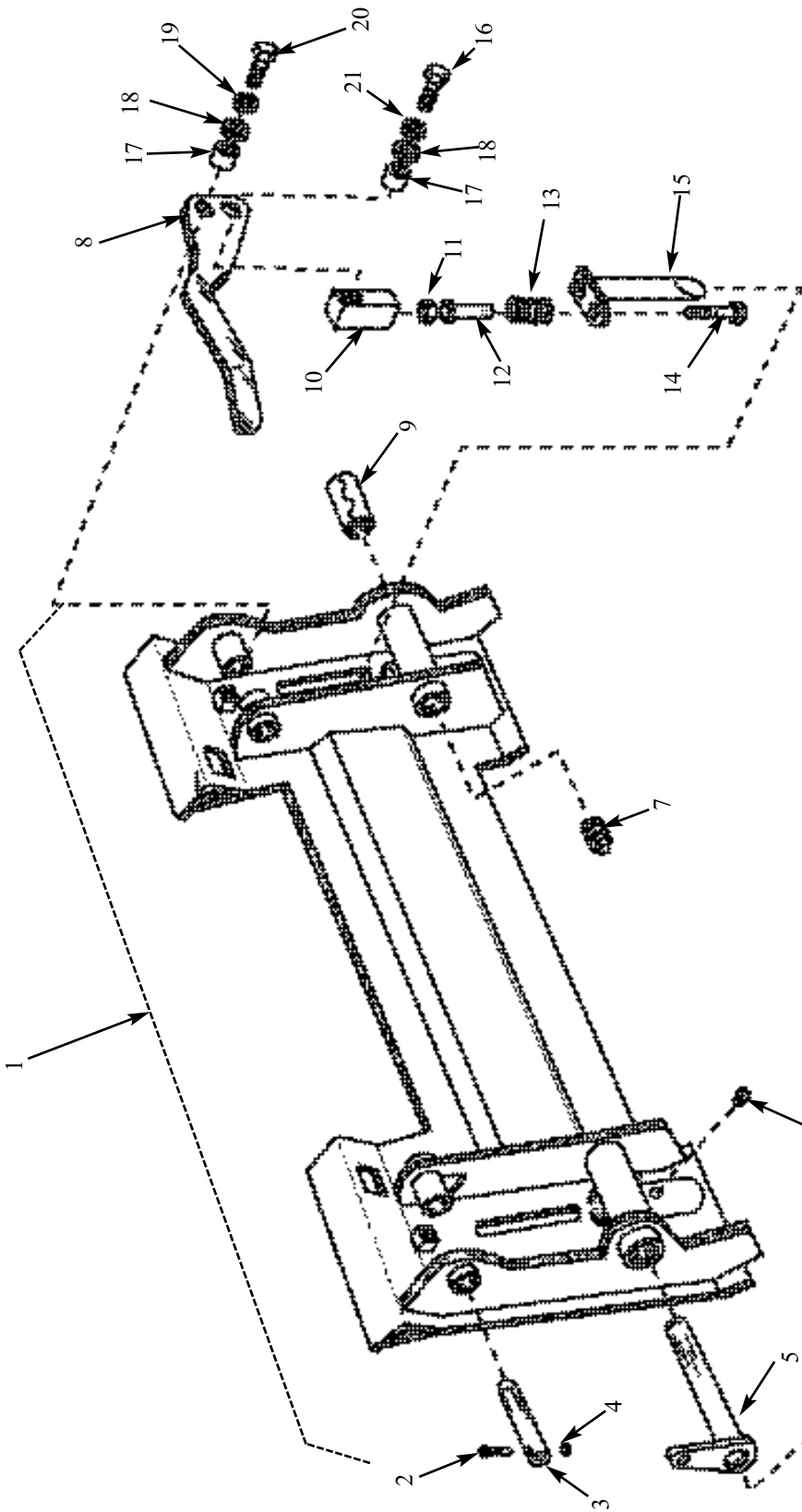

- | | | | |
|----|-----------------------|----|---------------------------|
| 1 | Quick - Tach Assembly | 12 | Spring Stabilizer Bushing |
| 2 | Bolt, Hex | 13 | Compression Spring |
| 3 | Hardened Pin | 14 | Hex Bolt |
| 4 | Nylok Nut, Hex | 15 | Lock Pin Assy RH & LH |
| 5 | Hardened Pin Ass'y | 16 | Hex Bolt |
| 6 | Grease Fitting | 17 | Stabilizer Bar Bushing |
| 7 | Plug | 18 | Flat Washer |
| 8 | RH & LH Handles | 19 | Spring Washer |
| 9 | Hardened Bushing | 20 | Hex Bolt |
| 10 | Linkage Block Bar | 21 | Lock Washer |
| 11 | Hex Nut | | |

6

C2649

QUICK - TACH 6.1

Preventative Maintenance

To keep the quick - tach locking pins and mechanism working freely, and to prevent pin and bushing wear, the quick tack must be lubricated every 8 hours of operations. More often in dirty applications.

Lubricate the quick - tach as follows:

- 1 Remove any attachment from the loader, raise the boom arms, engage the boom supports, engage the parking brake and shut off the engine.
- 2 Clean any dirt build up around the linkages.
- 3 Lubricate the grease fittings on each of the lock pin bushings with a good quality multi purpose lithium based grease until excess shows. (fig. C3590) Lubricate the quick - tach handles with penetrating oil. Move the handles to insure the locking pin linkage moves freely.
- 4 Lubricate the tilt cylinder pivot pins. (fig. C3591)
- 5 Lubricate the lower boom pivot pins. (fig. C3593)

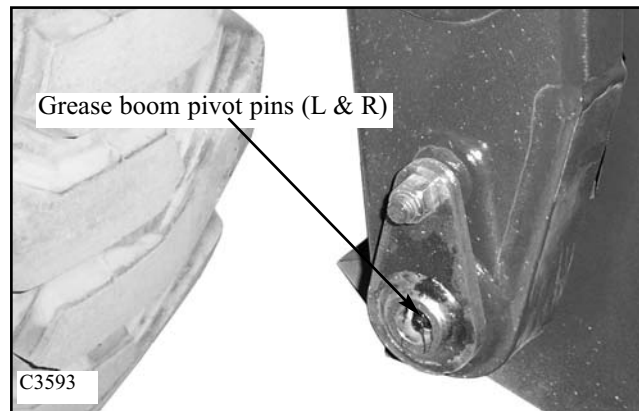
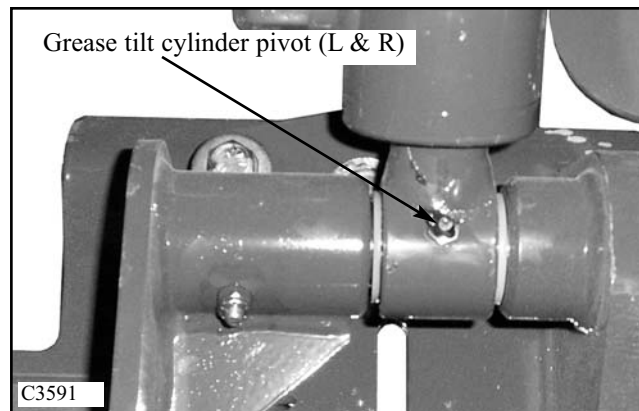
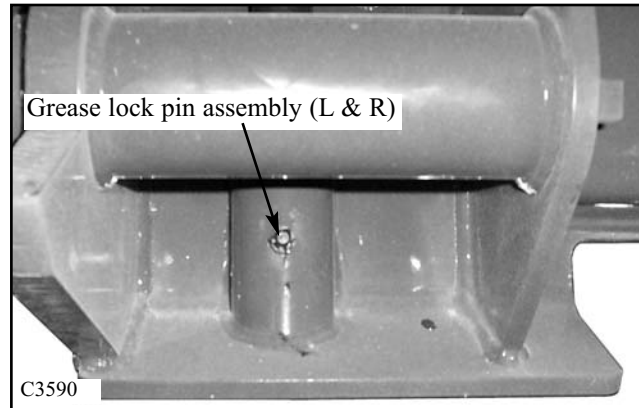

QUICK - TACH 6.1

Removal

- 1 Remove any attachment and lower the boom arms.
- 2 Start the engine and extend the hydraulic tilt cylinders approximately 12 inches. (fig. C3880)
- 3 Shut off the engine and engage the parking brake.
- 4 Remove the bolts retaining the upper pivot pins to the quick - tach frame until the quick-tach is level and the pins removed. (fig. C3880)
- 5 If this repair is being performed in a proper work shop, a portable floor jack works excellent for this next step. Place the floor jack under the quick - tach. (fig. C3881)
- 6 The floor jack is used to relieve the weight on the 2 lower pivot pins. Remove the upper pivot pins.
- 7 Remove the nuts retaining the 2 lower quick - tach pivot pins to the quick - tach or boom arms.(fig. C3882)
- 8 Remove the pivot pins using a brass drift punch and hammer.
- 9 Remove the quick - tach from the loader boom arms.

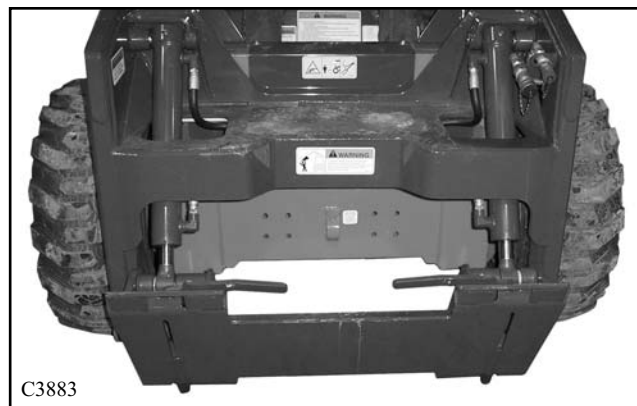
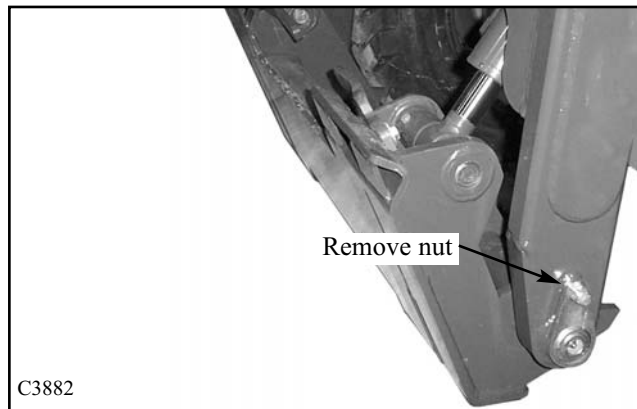
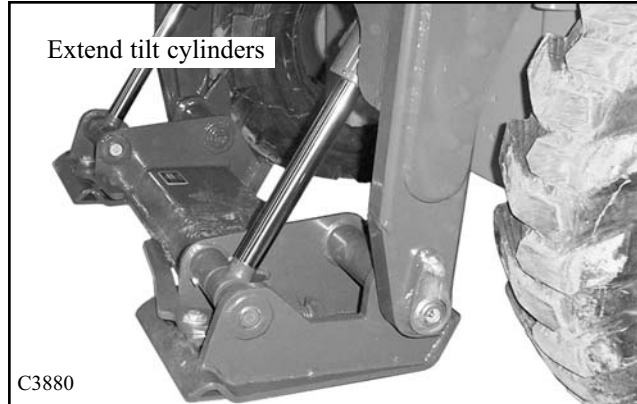

Installation

Upon installing the quick - tach to the loader boom arms:

- 1 Make sure all pivot pins and bushings are in good condition. Do not reuse worn parts. Replace pins and hardened bushings as required.
- 2 Use the floor jack to assist installing the quick - tach to the loader boom arms. (Or lay it down on a piece of wood. (fig. C3881)
- 3 Raise the bottom of the quick - tach up to align the boom arm pivot holes and the lower quick - tach pivot bushings. Install the 2 lower pivot pins, retaining bolts and or lock nuts.
- 4 Align the 2 tilt cylinder pivot bushings with the quick - tach bushings and install the pins and retaining bolts and lock nuts.(fig. C3882)
- 5 Lubricate all pivots until excess grease shows around the bushings and pins.

6

QUICK - TACH 6.1

Disassembly

Follow the exploded schematic of this section to assist in taking apart the locking mechanism and to assemble the system back together. Please note that the quick - tach does not have to be removed to service or replace locking mechanism parts.

- 1 Remove the bolt retaining the lock handle to the lock linkage. (fig. C3594)
- 2 Remove the bolt retaining the lock handle to the quick - tach frame. (fig. C3594)
- 3 Pull the locking pin and linkage out of the guide bushing. (fig. C3595)
- 4 Loosen the jam nut on the linkage block. Remove the bolt holding locking pin to the lock linkage block. (fig. C3596)
- 5 Separate the parts and inspect the spring for broken or sacking (compressed) coils. (fig. C3596) Replace parts as required.
- 6 Inspect the locking pin for wear. Make sure the beveled end of the pin is not worn or broken off the opposite side of the bevel. Check the fit of the pin in the quick - tach guide bushing. If the pin or bushing is excessively worn replace the pin or complete quick - tach assembly.
- 7 Inspect the lock handle mounting holes for fit against the handle pivot bushings. Replace the handle or pivot bushings as required if the fit is sloppy. (fig. C3596)
- 8 Check the fit of the lower pivot pins in the quick - tach. Discard worn pins and replace the hardened bushings in the quick - tach if so equipped.
- 9 Check and replace any grease fittings that are damaged or defective.

Assembly

Upon assembling the locking mechanism to the quick - tach, use 242 Loctite (blue) on all the mounting nuts and bolts.

- 1 When assembling the locking pin to the spring, bushing and linkage block, adjust the length of the bolt to 4 1/16 inches. (103mm). This is measured from under the head of the bolt up to, and against the linkage block. (fig. C1818) **This is very crucial for lock pin engagement to the attachment.**
- 2 Replace the rest of the lock mechanism in the reverse order above.
- 3 Lubricate all pins and bushings.
- 4 Check the lock mechanism by cycling the lock levers to ensure correct engagement through the attachment and sufficient pressure to hold the lock system down in the over - center position. (Engages and stay in the locked position)

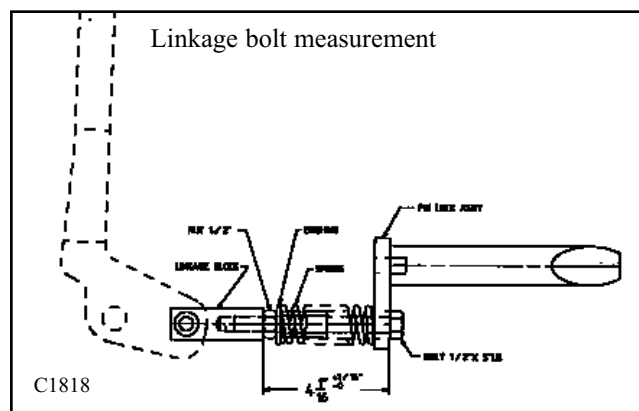
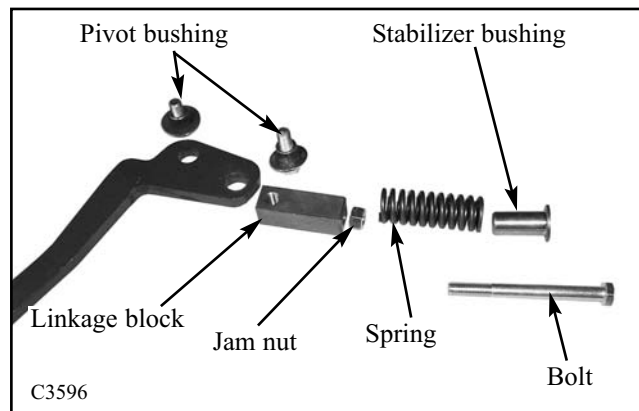
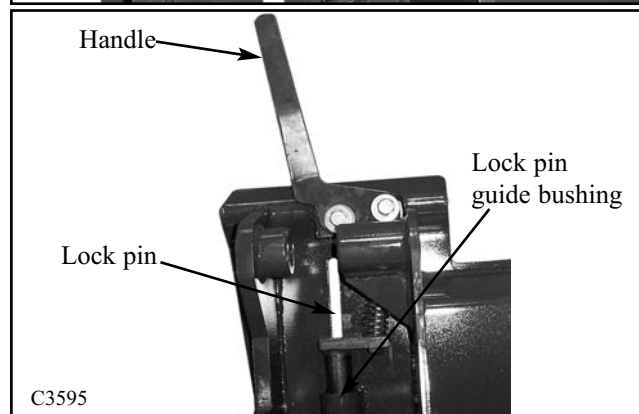
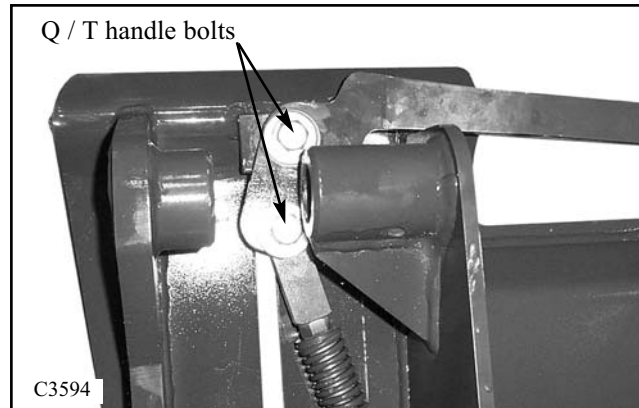

6

BOOM ARMS 6.2

Removal

- 1 Lower the boom arms and shut off the engine. Turn the ignition key to the "RUN" position and cycle the boom and tilt controls to relieve hydraulic backpressure. Lock the boom lift control in the float position.
- 2 Return the key to the "OFF" position and engage the parking brake (raise the restraint bar).
- 3 Remove the quick - tach assembly from the boom arms. (See Section 6.1)
- 4 Disconnect the hydraulic hoses between the boom arm and reservoir tanks. Cap the open hose ends to prevent contamination. (fig. C3601)
- 5 Fasten chains or lifting straps with an adequate capacity to sustain the weight of the boom arms. Most of the weight is at the front of the boom arms. Attach one set of straps as close as possible to the front, (fig. C1844), and the other set approximately half way toward the rear.
- 6 Using an overhead hoist, raise the boom arms enough to take the weight off of the lift cylinders. Remove the bolts from the pivot pins in the lift cylinders that are mounted in the boom arms. (fig. C3603)
- 7 Remove the pins by reaching between the ROPS and the boom arm and pushing the pin out toward you. Take care not to let the lift cylinder fall on your hand.
- 8 Remove the bolts from the upper rear boom arm pivot pins mounted through the main frame. (fig. C3604)
- 9 Remove the pivot pins using an appropriate drift punch and hammer. Use care, do not broom up the end of the pins.
- 10 Raise the boom arms enough to free from the loader and remove them.

Installation

- 1 Upon installation follow the above procedure in the reverse order.
- 2 Replace any worn or gouged pins and bushings
- 3 All stationary bushings should be coated with anti - seize compound to assist ease of future disassembly. Do not get the anti - seize compound on moving or pivoting parts. The compounds contain abrasives that may cause premature wear of pivot pins and bushings.
- 4 Torque the hydraulic hose fittings as outlined in the Section 1 Hydraulics torque chart page 1-35.

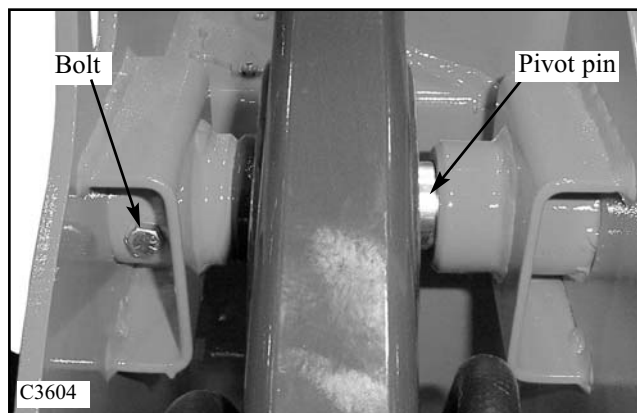
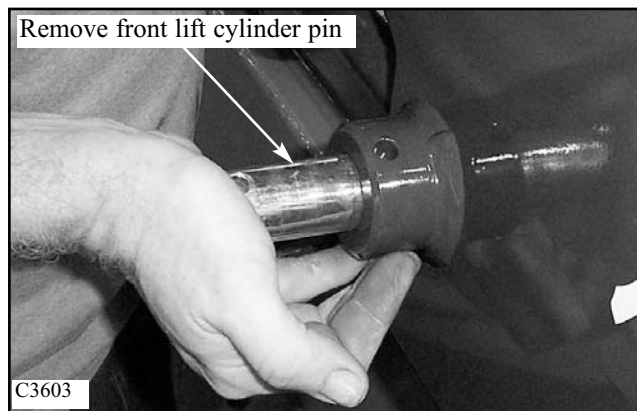
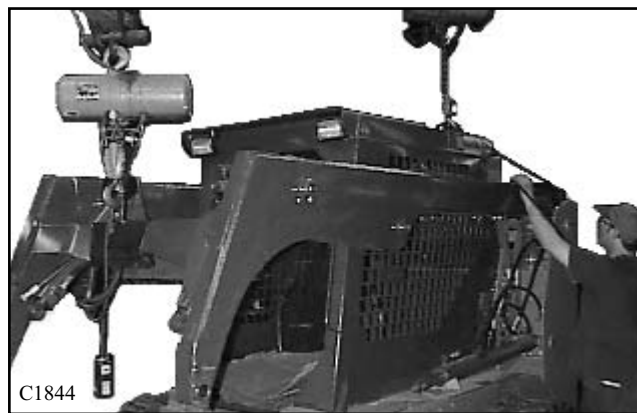

BOOM ARMS 6.3

Boom Arm Supports

For safety while performing regular service or maintenance work, the loader is equipped with boom supports. (fig. C3597) The boom supports, when extended, prevent the boom arm from lowering when servicing the hydraulic system, controls or other repair work while the engine is not operating.

The boom supports should be greased every 8 hours of use and engagement depth should be checked every time the supports are used.

- 1 Raise the boom arms, extend the boom supports and allow the boom arms to lower onto the supports. Do not pressure the hydraulic system against the boom supports.
- 2 Shut off the engine and engage the parking brake.
- 3 Measure the distance the boom support pins are protruding past the inner boom arm plate. Proper adjustment should have the support pin protruding past the inner boom arm plate by 1/4 of an inch. (6.5mm) (fig. C3597)
- 4 Adjust the engagement depth by removing the 3 screws each on the left and right dash panels to access the support pins and linkage. (fig. C3577) Only remove one side if there is only one side to be adjusted.
- 5 Loosen the jam nut on the support pin linkage. (fig. C3579) Use care to not damage the plastic center dash panel.
- 6 Screw the pin in or out the amount necessary to get the proper adjustment for support pin engagement on the boom arms.
- 7 To remove the support pins and linkage, remove both dash panels and pods to access the center boom support panel bolts. (fig. C3598)
- 8 Remove the bolts and center panel and the support pins and linkage may be removed, serviced or repaired.
- 9 Apply 242 Loctite (blue) to the nut and tighten it against the support pin when installing.
- 10 Lubricate the boom support pins and replace the dash panels.

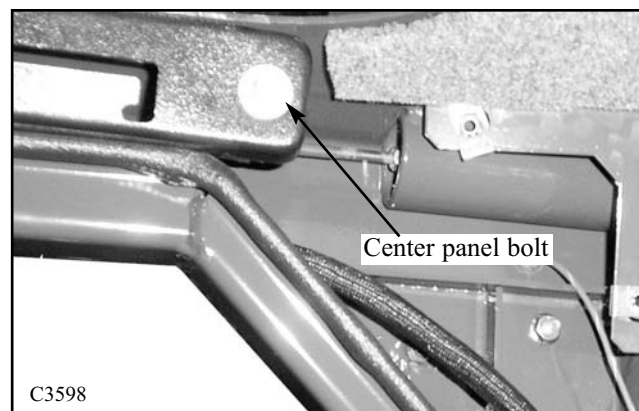
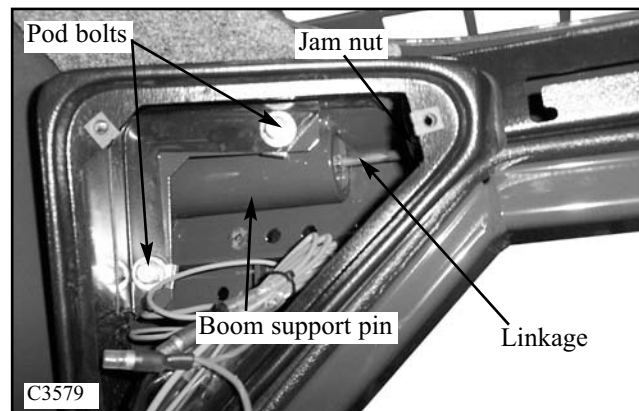
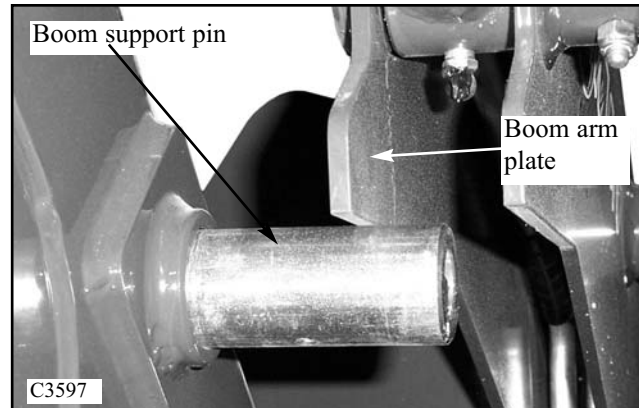

ROPS 6.4

Removal

1 Lower the boom arms, shut off the engine and engage the parking brake.

2 Remove the seat assembly and the hydrostatic shield. Access the battery compartment located behind the operators seat. Disconnect the battery terminals starting with the ground cables first. Disconnect the positive cable from the battery.(fig. C4667) Remove the rubber grommet in the RH corner of the battery compartment. Slide the positive cable through the hole in the corner of the battery box.

3 Disconnect the ground cable from the mainframe and Rops. (fig. C4675)

4 Disconnect the main wiring harness plug. (fig. C3885) To separate the main electrical harness connection, push the locking tab in the direction of the arrow and twist the collar clockwise to release.

5 Disconnect the restraint bar safety switch wiring. Trace the wiring to the connector on the LH side of the Rops. Remove any cable ties used to secure the wire harness to the frame.

6 Disconnect the throttle cable located in the LH control lever boot cover. Remove the bolts in LH and RH control lever boot covers. Remove the control lever boots covers by sliding them over the control lever handles.

7 Remove the screws for the cab filler shield located on the outside of the cab below the rear window.

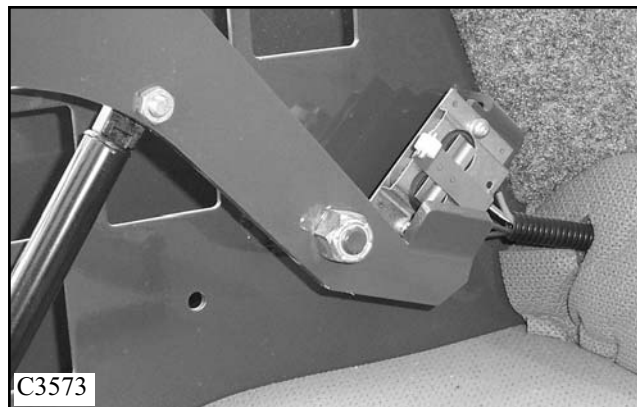
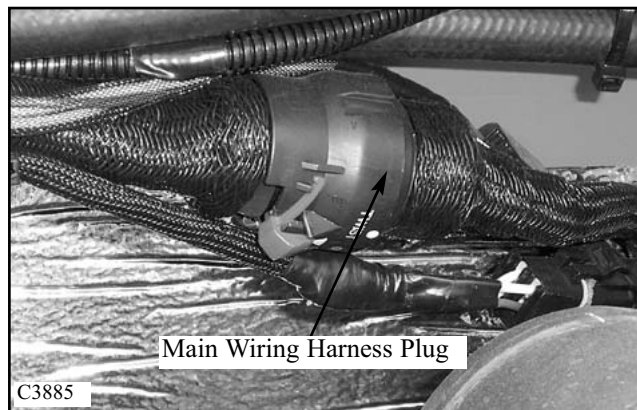
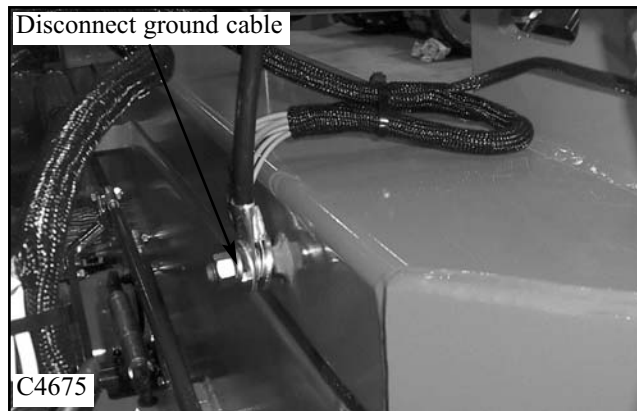
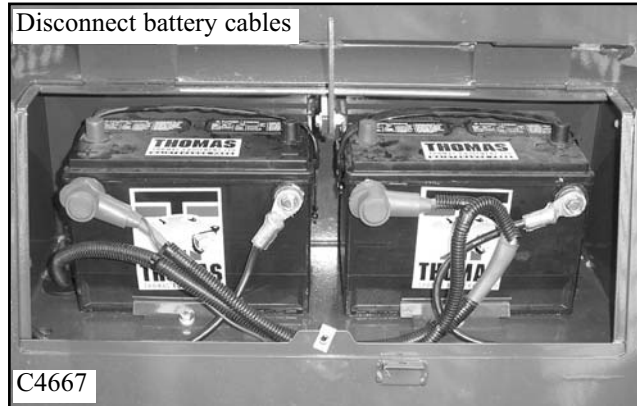

ROPS 6.4

Removal

7 Remove any cable ties that may be used to tie wiring and hoses to the ROPS. Check the engine compartment and the hydrostatic pump area for wiring connections and ties that will need to be disconnected from accessory circuits. If your loader is equipped with the two speed option, you will need to disconnect the wiring that connects to the two speed indicator on the LH cab leg.

8 Remove the nuts and the snubbing washers on the ROPS isolator mounts. There are 5 mounts locations on each ROPS. There are 2 mounts located in the front (fig. C3606) 2 mounts located in the bottom rear and 1 in the inside the ROPS at the rear. (fig. C3605) The 2 mounts located at the rear of the cab, have a access panel built in the design of the cab so the mounts can be serviced. (fig. C4676)

9 Attach chains or straps with a sufficient load rating to safely raise the ROPS from the frame. (fig. C3607)

10 Raise the ROPS using an over head hoist. Check for wiring that may still be connected and remove as required.

IMPORTANT

Check the ROPS mounting isolators every 150 hours for deterioration to prevent unwanted vibration and movement.

Installation

1 Upon assembling the ROPS to the loader mainframe, ensure the mounting isolators are in serviceable condition. Replace any worn, damaged or weathered isolators.

2 Reverse the removal procedure taking care not to pinch any wiring and connections.

3 Torque the ROPS mounting isolator nuts at 55 lbs / ft. (75 Nm)

4 See Section 4 for proper adjustment of the controls and throttle.

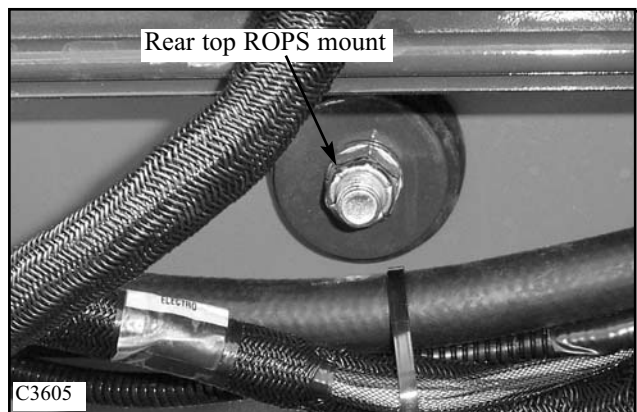
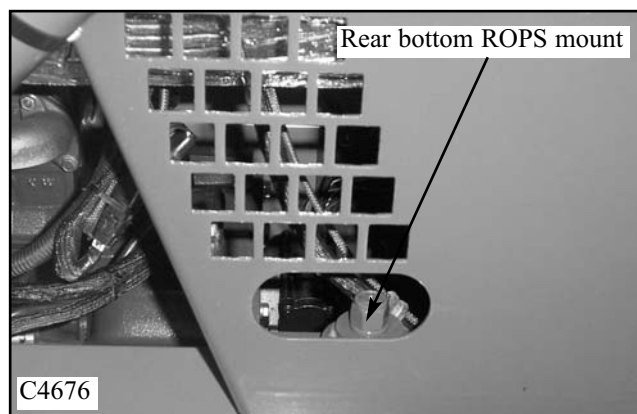
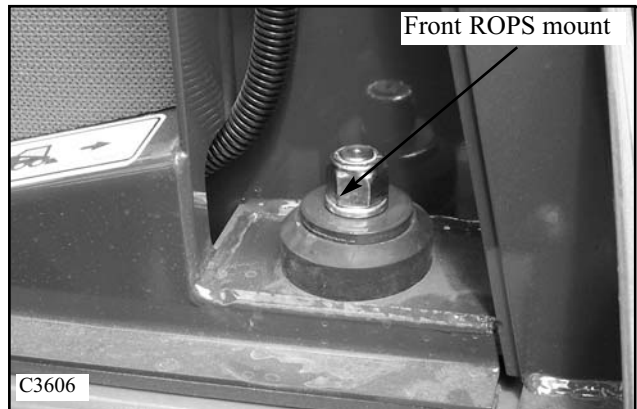

REAR DOOR 6.5

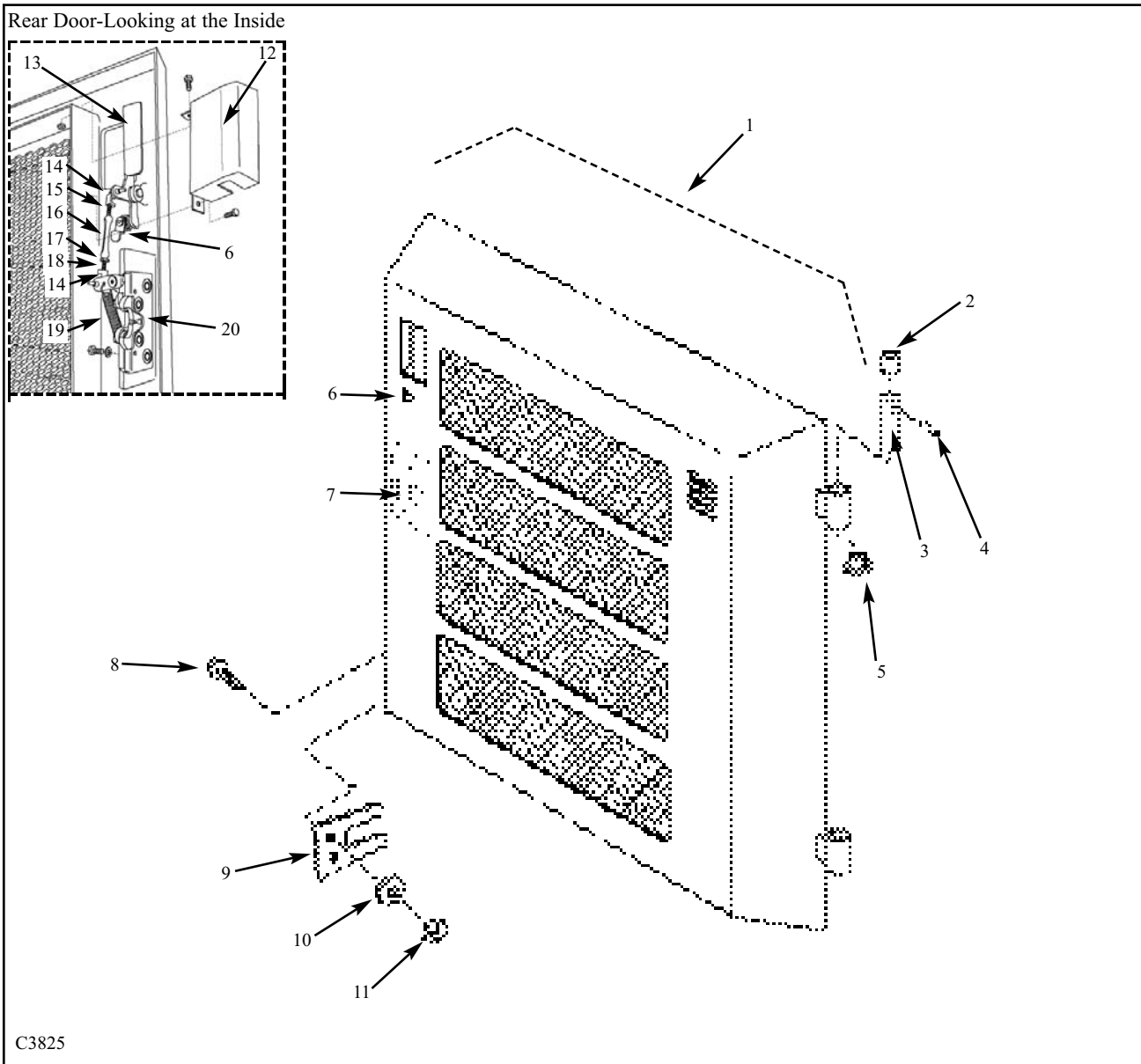

C3825

- | | | | |
|----|------------------------------------|----|--|
| 1 | Rear Door Assembly | 11 | Nut |
| 2 | Bearing | 12 | Latch Cover Assembly |
| 3 | Pin | 13 | Handle |
| 4 | Pin, Split Spring | 14 | Clip, Rod Plastic |
| 5 | Bearing | 15 | Rod, .161" Dia. x 2" W/ # 10-24 LH Threads |
| 6 | Cylinder Lock | 16 | Turnbuckle, # 10-24 Treads |
| 7 | Bolt Rotary Striker for Door Latch | 17 | Nut, Nylok #10-24 |
| 8 | Carriage Bolt | 18 | Rod, .161" Dia. x 2" W/ # 10-24 RH Threads |
| 9 | Door Guide Plate | 19 | Spring |
| 10 | Flat Washer | 20 | Latch, Rotary LH |

6

REAR DOOR 6.5

Removal

- 1 Open the rear door of the loader. Remove the split pins retaining the door pivot pins. (fig. C4678)
- 2 Using a hoist, raise the rear door to take the weight off the pivot pins. (fig C4679)
- 3 Remove the pivot pins from the frame.
- 4 Replace any worn pivot bushings or pins as required.
- 5 Remove all the components for the latch handle and locking mechanism inside the rear door. (fig. C4680)
- 6 Remove the door guide plate at the bottom corner of the rear door. (fig C4680)
- 7 Remove the sealing trim on the door baffle. Inspect the trim for damage and replace if necessary.

Installation

- 1 Replace the door to the frame in the reverse order as above.
- 2 Adjust the door latch to provide an even fit around the outside of the door. When adjusting the latch remember that it has a double locking mechanism. Make sure that the latch is completely locked on the striker bolt before doing your final adjustments.
- 3 Adjust the door guide plate so the rear door looks level with the engine compartment cover. Make sure the door slides freely into the closed position without the door guide binding on the pin located on the frame. Check the door guide plate for a tight fit to the pin with the door in the closed position. This prevents the door from moving ahead and damaging the rad / cooler.
- 3 Check the fit of the sealing trim to the cooler. It is important to have a tight fit so air directed by the cooling fan escapes through the door baffle. Adjust the cooler is necessary. See section 1 page 1-34

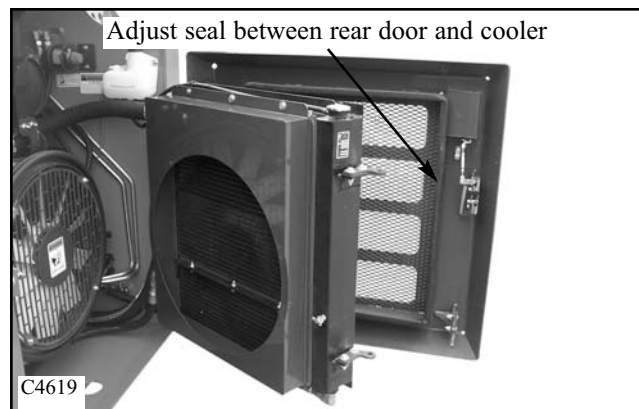
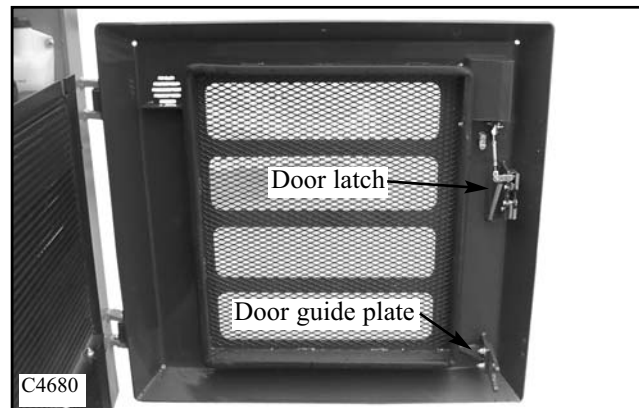
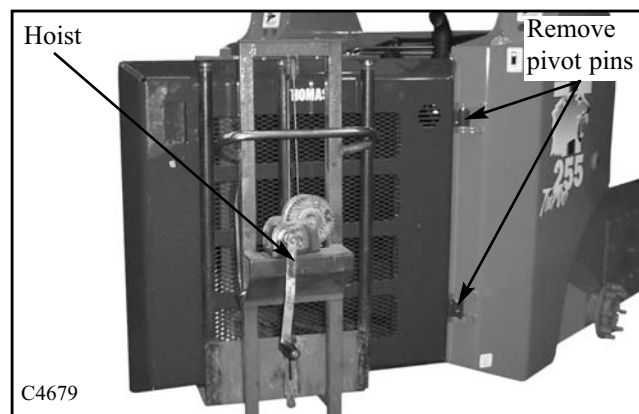
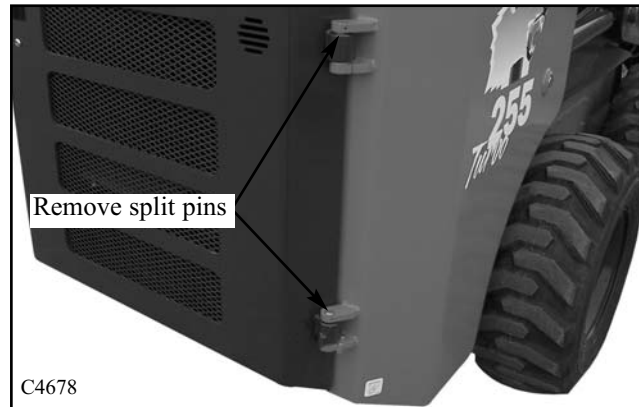

SECTION 7 ENGINE

Engine Maintenance	7.1
Lubrication System	pg. 7-2 ~ 3
Fuel System.....	pg. 7-4 ~ 5
Air Filter.....	pg. 7-6 ~ 7
Cooling System	pg. 7-8 ~9
Fan Belt	pg. 7-10
Cylinder Head	7.2
Valve Adjustment.....	pg. 7-11
Compression Test	pg. 7-12 ~ 13
Cylinder Head Torque	pg. 7-13
Engine Replacement	7.3
Removal	pg. 7-14 ~ 22
Installation	pg. 7-23
Engine Specifications	7.4
Dimensions, Capacities, Service Limits & Clearances	pg. 7-24
Trouble Shooting	7.5
Guide	pg. 7-25 ~ 26



ENGINE MAINTENANCE 7.1

Lubrication System

Engine Oil and Filter:

Engine oil and filter changes should be made with the engine warm. Change the engine oil every 150 hours and the oil filter every 300 hours of operation.

Park the loader on a level surface, lower the boom arms, engage the parking brake and shut off the engine.

1 Access the engine compartment by opening the rear door and lifting the engine cover. (fig. C3610)

Access the engine compartment

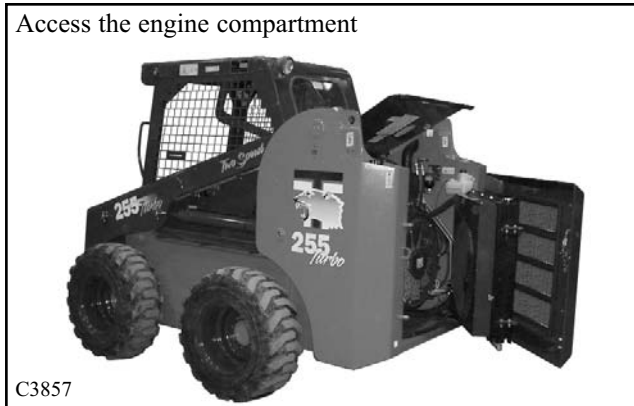

2 Locate the oil pan drain hose at the bottom of the engine oil pan. Loosen the plug on the end of the hose. Have a catch container ready to contain approximately 14 qts (13 liters) of fluid. (fig. C4681) Drain the oil.

Oil pan drain hose



IMPORTANT

Thomas recommends that you abide by all applicable environmental regulations when disposing of oil

3 Remove the oil filter using an appropriate filter wrench. If the oil filter area is excessively dirty, clean around the filter area before removing the oil filter to prevent contaminant's reaching the engine lubricating system. (fig. C3786)

4 Check the oil filter mounting adapter area after removing the oil filter and check for dirt on the sealing surface and to make sure the oil filter O-ring seal has not stuck to the oil filter adapter.

5 Lubricate the new oil filter O-ring seal with engine oil and install to the engine hand tightened.

6 Replace the oil pan drain plug to the hose. Make sure the seal is still in place and in good condition. Tighten the oil pan drain plug not exceeding 25 ft lbs (34 Nm.)

Engine oil filter location

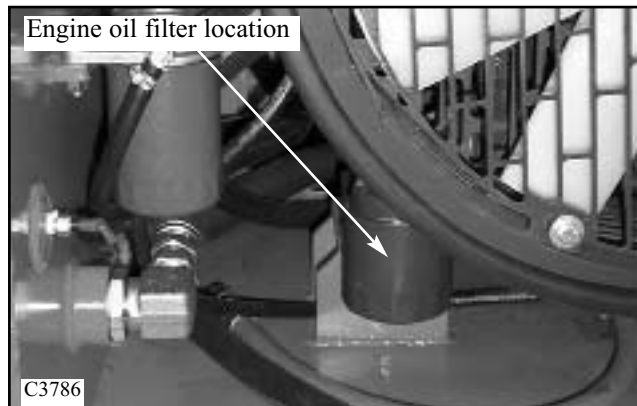

ENGINE MAINTENANCE 7.1

Lubrication System (cont'd)

7 Remove the oil fill cap located in the engine rocker arm cover. (fig. C4682) Add 13.2 liters (14qts) of 5W40 API classification CF engine oil. Replace the fill cap in the rocker arm cover.

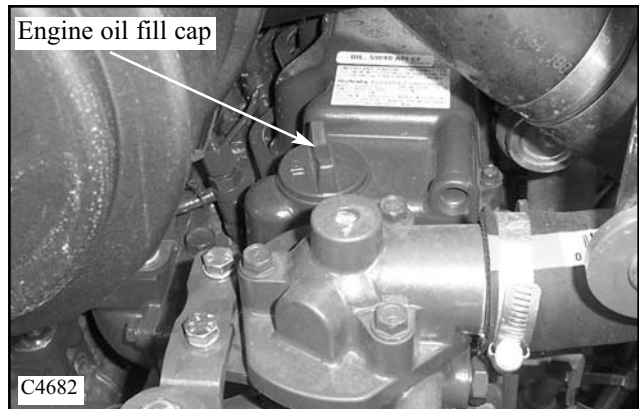

8 Start the engine and check for leaks around the oil filter and oil pan drain plug. (fig. C4681) Allow the engine to operate for approximately 5 minutes and then shut it off.

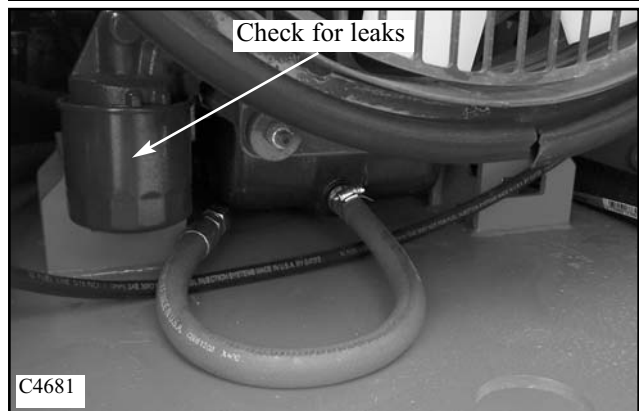

9 Check the level of the engine oil. (fig. C3614) Add oil as required to bring the oil to the top mark of the engine oil dip stick. (fig. C642) Do not over fill.

Change the engine oil every 75 hours and the engine oil filter every 150 hours.

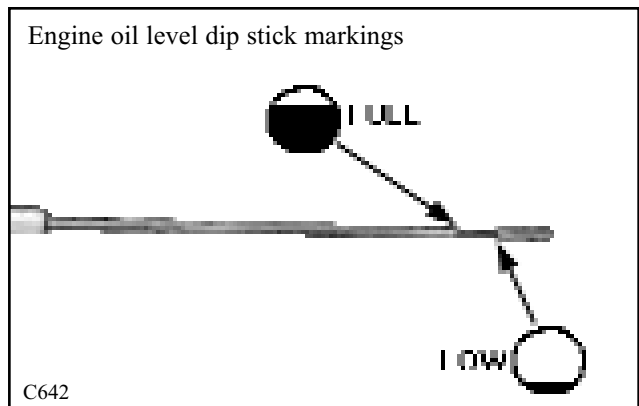
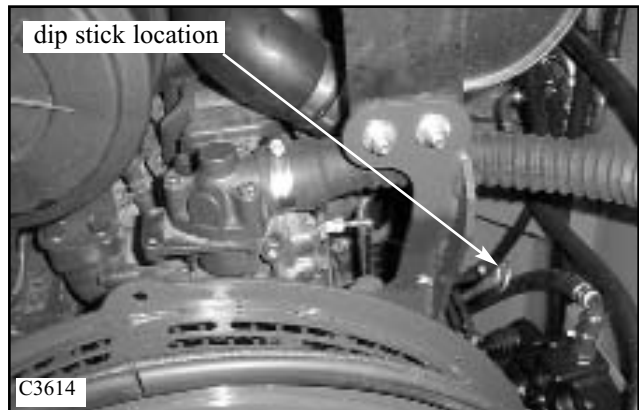

ENGINE MAINTENANCE 7.1

Fuel System

Fuel Filter:

The fuel filter is a spin on type on the inner side of the oil tank attached to a bracket and is located in the engine compartment on the engine mounting bracket. Change the fuel filter every 400 operating hours.

To change the fuel filter: Park the loader on a level surface, lower the boom arms, engage the parking brake and shut off the engine.

- 1 Access the engine compartment by opening the rear door and lifting the engine cover. (fig. C3857)
- 2 Close the fuel line shut off petcock located on the lower right hand side of the fuel tank. (fig. C4683) This will prevent fuel loss due to siphoning.
- 3 Remove the fuel filter using a filter wrench. (fig. C3616) Check to make sure the fuel filter O-ring seal has not stuck to the filter adapter mount.
- 4 Lubricate the new fuel filter O-ring seal with light oil. Tighten the filter to the adapter mount hand tight.
- 5 Open the fuel line shut off petcock.

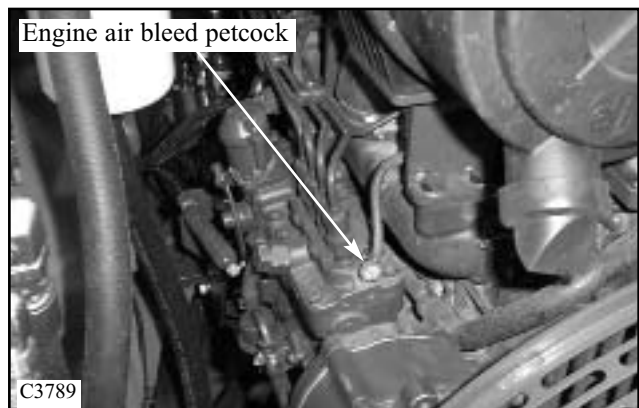
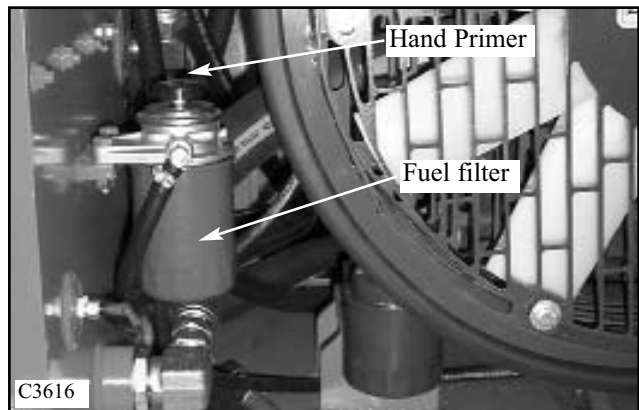
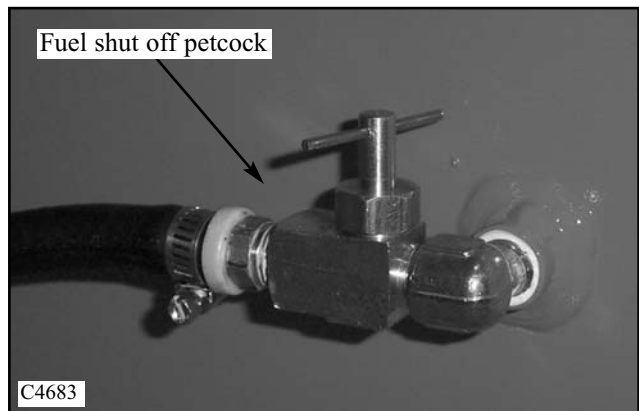

	WARNING
When servicing the fuel system, stay away from open flame and sparks. No smoking	

6 Open the engine fuel line / air bleed petcock located just to the left of the fuel injection pump. (fig. C3789) Prime the fuel system by using the hand primer. Pump the hand prime 4 to 5 times. Start the engine and allow to idle for 5 minutes. Close the fuel line / air bleed petcock.

7 Check for fuel leaks.

If the engine fails to continue operating, it may be necessary to bleed the fuel system of air after changing the fuel filter or running out of fuel. See Bleeding the Fuel System, next page.

7

ENGINE MAINTENANCE 7.1

Fuel System (cont'd)

Bleeding the Fuel System:

If the loader has been run dry of fuel, or the fuel filter has been changed, it may be necessary to bleed the air from the fuel lines.

- 1 Replenish the fuel reservoir (tank) with a minimum of 10 gallons (45 £) of fuel.
- 2 Make sure the fuel line shut off petcock is fully open. (fig. C3955)
- 3 Loosen the fuel filter bleeder bolt and allow the fuel to siphon through the fuel line and filter. (fig. C3786) Tighten the fuel filter bleeder bolt.
- 4 Loosen the air bleed petcock located next to the fuel injection pump. (fig. C3789)
- 5 Prime the fuel system by using the hand primer on the fuel filter. Pump the hand prime about 4 to 5 times.
- 6 Turn the engine over with the starter until the engine starts to smoke. Do not engage the starter for more than 15 second intervals. Allow the starter to cool between starting attempts for 1 (one) minute.
- 7 Pre- heat and start engine. Allow to operate at idle speed for 5 minutes. Shut off the engine.
- 8 Close the air bleed petcock. (fig. C4684)
- 9 Check for fuel leaks.

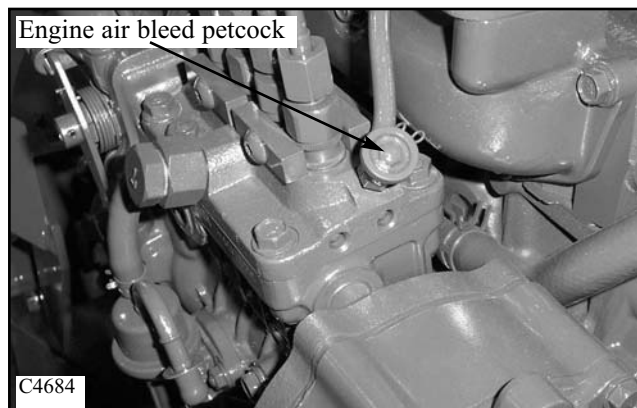
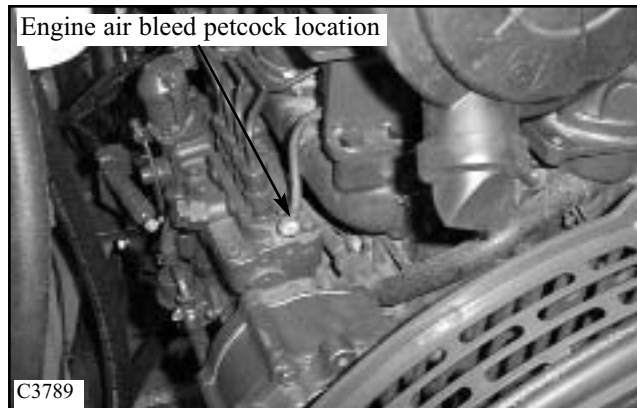
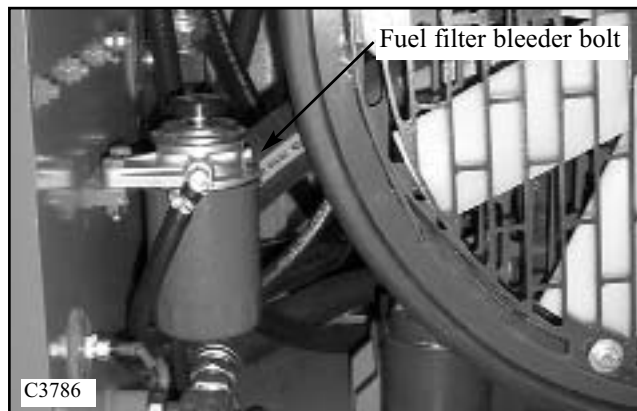
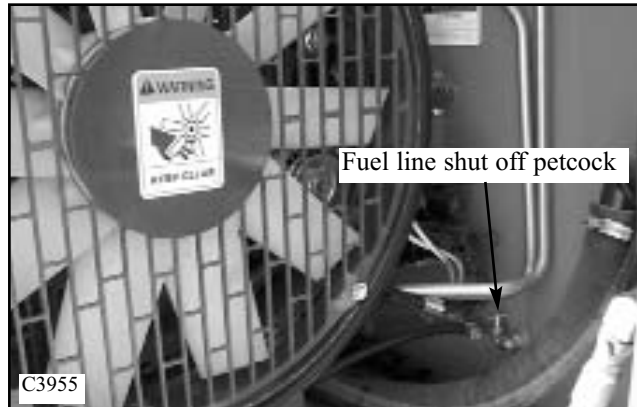

ENGINE MAINTENANCE 7.1

Air Filter

The loader is equipped with dual dry cartridge, radial seal type filter elements. The larger outside element is called a primary and the one inside the primary is referred to as a safety element. (fig. C653)

The loader is equipped with an air restriction indicator that functions while the engine is operating. When the air filter elements require servicing the indicator light on the dash panel will illuminate.

Over servicing the air filters can damage the seals and pleated filter material. When the air restriction indicator light illuminates in the dash panel, replace the primary air filter element with a new one. On average, the safety air filter element will be replaced once for every three (3) primary air filter element changes, if the primary filter hasn't been damaged due to over servicing.

To service the air filters, park the loader on a level surface, lower the boom arms, engage the parking brake and shut off the engine.

Daily Checks

Checking the Restriction Sensor:

1 The air filter restriction sender wires should be visually checked daily for breaks and proper connection. (fig. C4685)

2 With the engine operating at low idle, place your hand over the air intake inlet to restrict air flow to the engine. The indicator light on the dash panel should illuminate promptly. Do not hold your hand over the air intake excessively, just long enough for the indicator light to illuminate then quickly release your hand from the intake.

NOTE: If the indicator light fails to function replace the restriction sender or check for shorts in the wiring circuit.

3 Air cleaner hoses and clamps should be inspected daily for proper tightness and verify air inlet hose integrity. Replace any worn or cracked inlet hoses immediately.

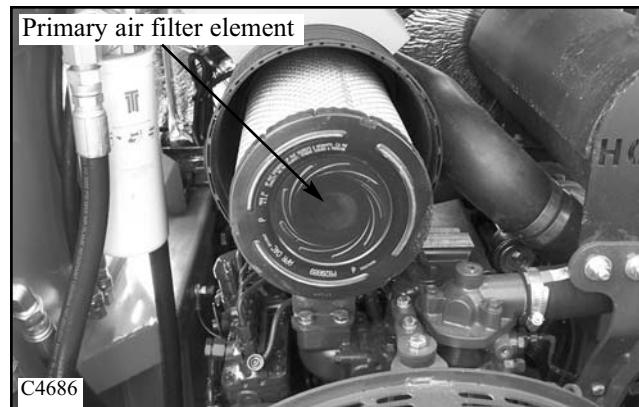
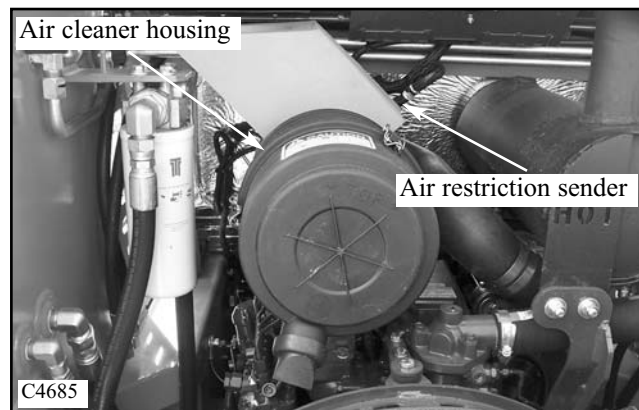
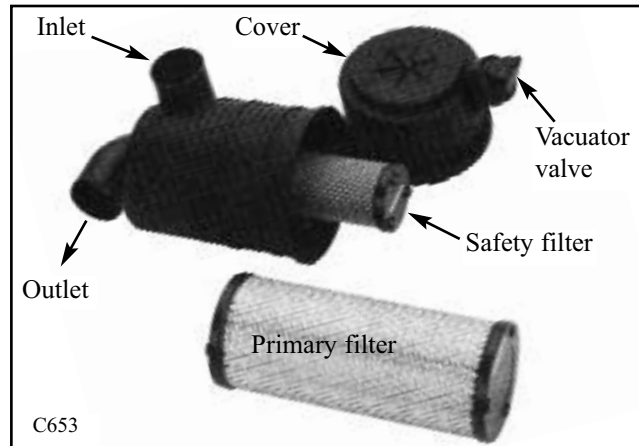

IMPORTANT

Air filter service recommended only when the service indicator light illuminates.

Servicing the Air Filter Elements:

1 Release the latches holding the air cleaner cover to the canister body. (fig. C3619)

2 Pull straight out on the primary element to remove from the air cleaner housing. (fig. C4686) Do not twist or force the filter. This may damage the sealing area around the end of the air filter element.

ENGINE MAINTENANCE 7.1

Air Filter (cont'd)

3 If required, remove the safety air filter element by pulling straight out of the air cleaner housing. (fig. C4687)

4 After removing the air filter elements, carefully wipe out any excess dirt from the air cleaner housing. (fig. C3622)

5 Check the air filter element seal before installing to the air cleaner housing. (fig. C2201) Be sure the seal is not damaged, torn or gauged. Do not use a filter with a damaged seal.

6 When installing the air filter elements to the air cleaner housing, support the back of housing with one hand and push the air filter element into position as gently as possible.

7 Install the air cleaner cover onto the housing. Be sure to align the latch hooks with the notches in the air cleaner housing.

Do not use the latches to push the air filter elements into position.

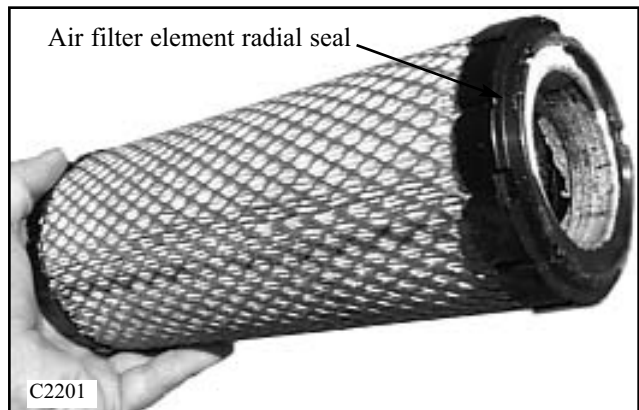
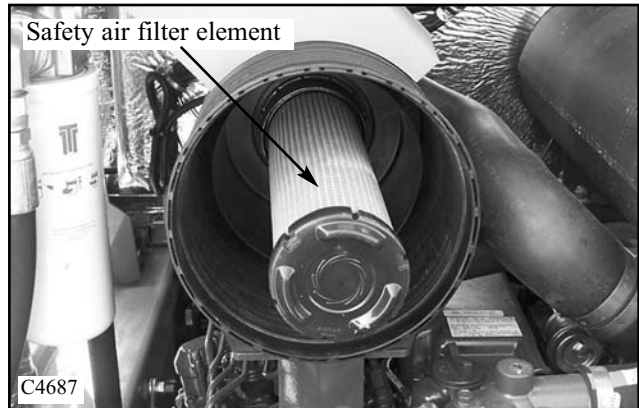

ENGINE MAINTENANCE 7.1

Cooling System

Daily Checks:

The loader is equipped with a liquid cooled diesel engine that requires daily coolant level checks and radiator service if necessary.

The cooling system should always be checked when the engine is cool.

Park the loader on a level surface, lower the boom arms, engage the parking brake and shut off the engine.

- 1 Access the engine compartment by opening the rear door and lifting the engine compartment cover.
- 2 Visually inspect the radiator cooling fins for dirt or debris build up that may be blocking air flow through the radiator. (fig. C4621) Blow any dirt or debris out with compressed air and / or water. Do not exceed 40 psi (2.7 Kg / cm²) Any bent cooling fins should be carefully straightened to prevent core damage.
- 3 Visually inspect the coolant overflow tank for the proper coolant level marked on the tank. (fig. C3625) Add a 50 / 50 mixture of ethylene glycol and water as required.



WARNING

To prevent eye injury, wear safety goggles when cleaning with compressed air



CAUTION

To prevent radiator fin damage, do not use air pressure higher than 40 psi (2.7 kg / cm²)



WARNING

Do not remove the radiator cap when the engine is hot.

- 4 Remove the radiator cap to verify the coolant level in the radiator. If the coolant level is below the upper part of the radiator tank, and the coolant bottle is still full, then either the radiator cap is defective or there is a coolant leak in the cooling system. Perform a pressure test of the cooling system.

Testing the Cooling System:

- 1 Ensure the radiator is full of coolant.
- 2 Start the engine operate until warm, **NOT HOT!**
- 3 Shut off the engine and carefully remove the radiator cap. Use extreme caution.

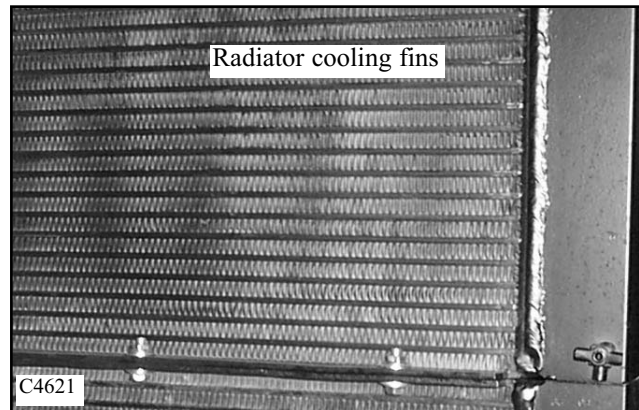
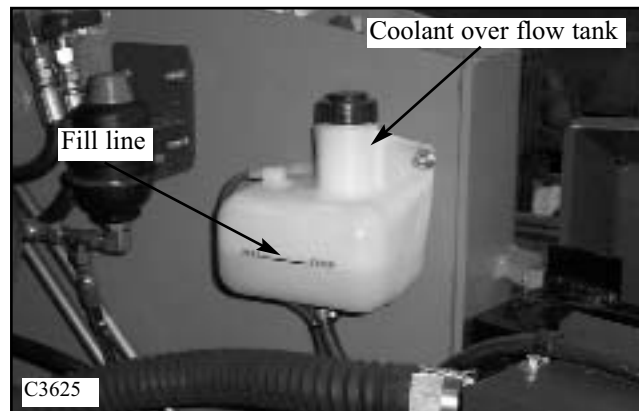
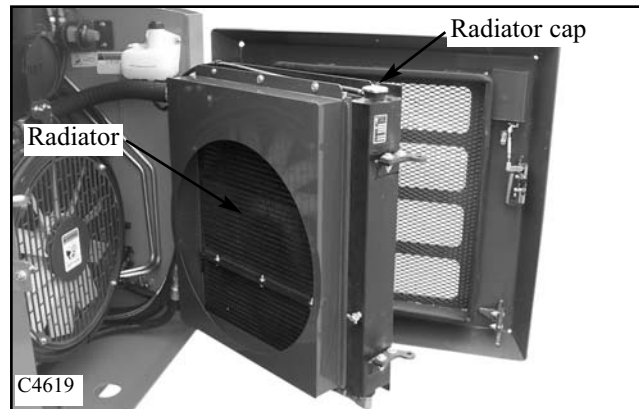

WARNING

Always use a pre - mixed or diluted coolant to prevent engine over heating, freezing and proper water pump lubrication

ENGINE MAINTENANCE 7.1

Cooling System (cont'd)

4 Attach a radiator tester and increase the pressure to 1.12 kg / cm² (16 psi).(fig. C172) Inspect the radiator, hoses and engine block for external leaks. Repair as required.

5 Attach a radiator tester to the radiator cap. (fig. C173) Apply 1.12 kg / cm² (16 psi) pressure to the radiator cap. The pressure should not drop more than 0.3kg / cm² (4.3 psi) in 10 seconds. Replace the radiator cap if required.

If no external leaks are found, and the radiator cap tests good, there may be an internal problem with the engine such as a gasket, cylinder head or block defect. Consult a Kubota Repair Manual P / N 46577 (Kubota P / N 97897-01712) to assist in engine disassembly and inspection.

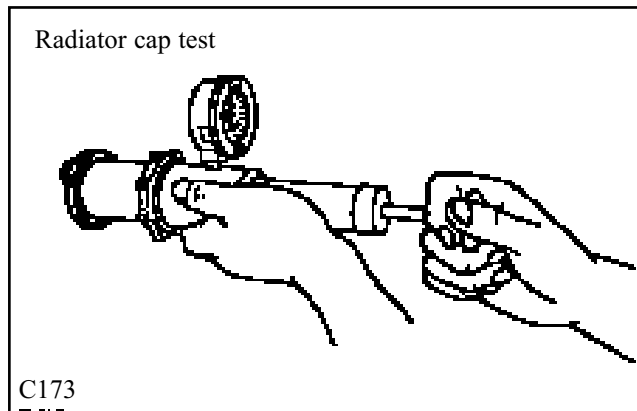
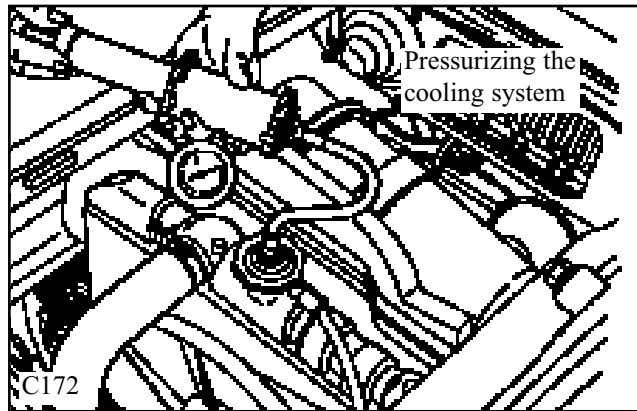

 WARNING
Do not remove the radiator cap when the engine is hot.

Coolant Replacement:

The engine coolant should be changed every 2 years or every 1000 hours of operation, whichever comes first. To change the coolant:

Park the loader on a level surface, lower the boom arms, engage the parking brake and shut off the engine.

1 Make sure the engine is not hot to touch. Remove the radiator cap.

2 Loosen the radiator drain petcock located lower left corner of radiator. (fig. C4619) Be prepared to contain 4.2 gal (16 liters) of fluid.

3 Be sure to tighten the radiator drain petcock.

5 Pre - mix the engine coolant, ethylene glycol, to equal parts of water. (50 / 50 ratio) Add the mixed coolant to the engine radiator. The cooling system will hold approximately 4.2 gal (16 liters) of coolant. Never use coolant undiluted. Pure coolant does not absorb and pass heat efficiently. It will also gel in cold weather.

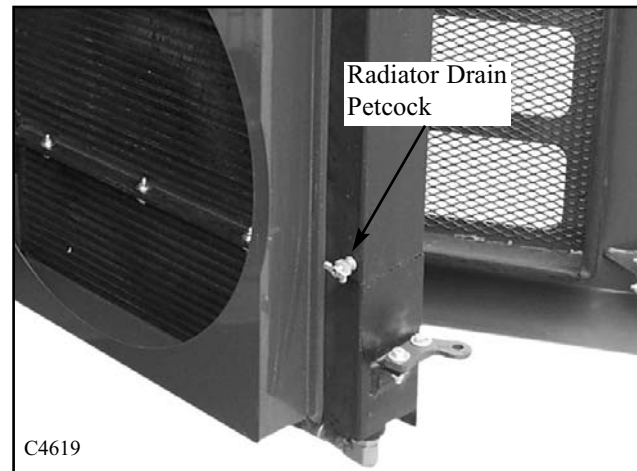

ENGINE MAINTENANCE 7.1

Fan Belt Adjustment

The fan (alternator) drive belt should be checked daily for tension and wear. The drive belt should be replaced promptly when fraying of the belt cords or cracks in the rubber are observed. Failure to replace the drive belt could lead to slippage or complete failure, causing the engine to over heat and lead to extensive repairs.

To Adjust the Fan Belt:

- 1 Park the loader on a level surface, lower the boom arms, engage the parking brake and shut off the engine.
- 2 Access the engine compartment by opening the rear door and cooler assembly. Lift the engine cover. (fig. C4619)
- 3 Locate the drive belt. Fig. C2759 shows the drive belt without the cooling fan and its guard obstructing the view.
- 4 Check the drive belt tension midway between the alternator and crankshaft drive pulley. (fig. C3866)
Correct tension is 10 ~ 12mm deflection @ 98 newton force. (3 / 8 ~ 1 / 2" deflection @ 22 lbs force).

Fan Belt Replacement:

- 1 Loosen the 2 bolts on the alternator and allow the belt tension to loosen off.
- 2 Unfasten the 4 bolts retaining the fan guard shield to the fan guard. Remove the cooling fan and the fan spacer from the pulley. Remove the shield.(fig.C4618)
- 3 Pull the drive belt off the alternator pulley, crankshaft pulley and remove from around the fan pulley.
- 4 Replace in reverse order and adjust belt tension as described above.

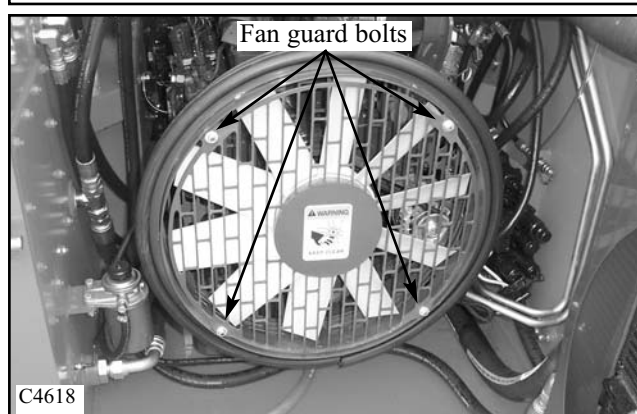
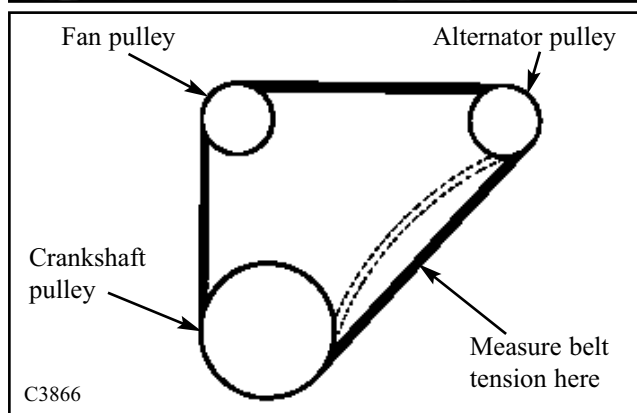
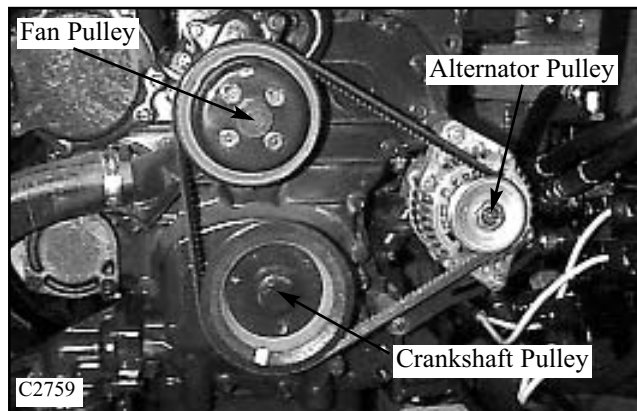
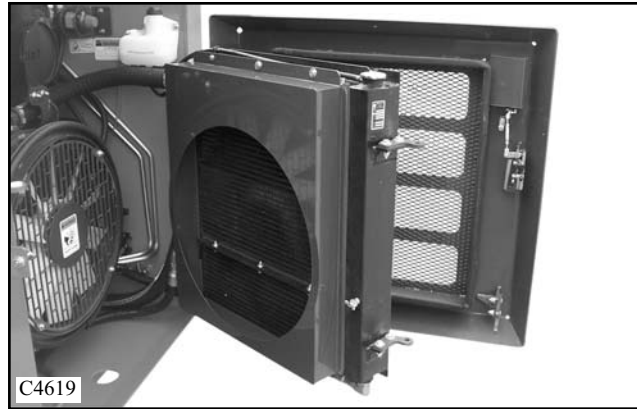

CYLINDER HEAD 7.2

Valve Adjustment

The engine used in this application uses a solid lifter (tappet) design that requires periodic maintenance of the rocker arm to valve clearance. (Valve lash)

Valve clearance should be checked every 500 hours of operation. Always check the valve clearance while the engine is cold. **Correct valve clearance is 0.23 ~ 0.27mm (0.0091 ~ 0.0106in).**

Procedure to Check / Adjust the Valve Clearance:

- 1 Park the loader on a level surface, lower the boom arms, engage the parking brake and shut off the engine. Remove the ignition key for safety.
- 2 Allow the engine to cool to room temperature.



WARNING

Do not adjust the valve clearance while the engine is hot. Clearances provided are for cold engine adjustment only.

3 Access the engine compartment by opening the rear door and lifting the engine compartment cover.

4 Remove the nuts and washers retaining the valve cover to the engine cylinder head and remove the cover. (fig. C4665)

NOTE: The crankshaft pairs pistons # 1 and # 4, and pistons # 2 and # 3 to rise and fall at the same time. The camshaft valve timing though, has the cylinder pairs on different cycles of operation.

Example: If both pistons on # 1 and # 4 were at top dead center (TDC), one of the cylinders would be on the compression stroke (both valves closed) the other cylinder would be starting the intake stroke. (Intake valve starting to open).

5 Turn the engine over until the intake valve is just starting to open on number 1 (one) cylinder. (Cylinder closest to radiator) This valve action means that cylinder number 4 (next to flywheel) is on the compression stroke, with both valves closed. This is the proper point to check and / or adjust the intake and exhaust valves on cylinder number 4.

6 Insert a feeler gauge between the rocker arm and the intake or exhaust valve on cylinder number 4. (fig. C551) If necessary, loosen the jam nut on top of the rocker arm and turn the adjustment screw to acquire correct valve clearance. **Correct valve clearance is 0.23 ~ 0.27mm (0.0091 ~ 0.0106in).**

7 Rotate the engine after checking / setting cylinder number 4 valves, until cylinder number 4 intake valve start to open. This position means that cylinder number 1 (one) is on the compression stroke and can have the intake and exhaust valves checked and / or adjusted.

Correct valve clearance is 0.23 ~ 0.27mm (0.0091 ~ 0.0106in).

8 Repeat the procedure for cylinder pairs 2 and 3. As one of the cylinders intake valves are just starting to open the opposite cylinder is on the compression stroke and can have it's valves adjusted.

Correct valve clearance is 0.23 ~ 0.27mm (0.0091 ~ 0.0106in).

9 Rotate the engine 2 ~ 3 complete revolutions and recheck the valve clearances by repeating the procedure above.

10 Replace the valve cover. Tighten the mounting nuts to 1.6 ~ 2.3 Nm (1.15 ~ 1.66 ft / lbs).

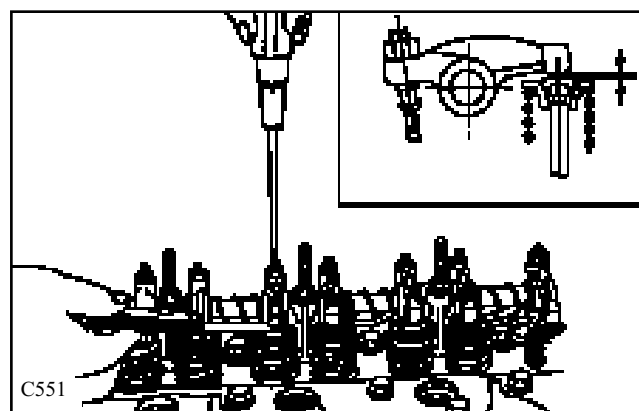
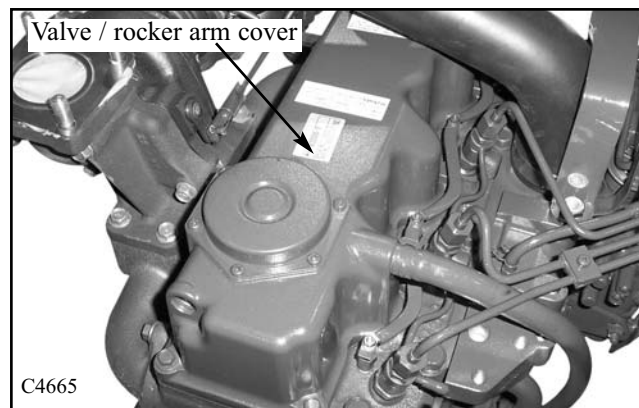

7

CYLINDER HEAD 7.2

Compression Testing

Testing the engine for compression is not a normal part of a scheduled maintenance procedure, but is important when trying to diagnose engine power or unusual performance related problems with the engine.

Before performing a compression test, be sure the battery is fully charged and valve clearances are correctly adjusted. See page 7-12. Be sure the air cleaner and exhaust systems are free of obstructions, to prevent a false or low reading

The engine should be warmed up for approximately 5 minutes prior to compression testing.

To Perform Compression Test:

- 1 Move the loader to a level surface, lower the boom arms, engage the parking brake and shut off the engine. Remove the ignition key for safety.
- 2 Access the engine by opening the rear door and raising the engine compartment cover.
- 3 Disconnect the wiring plug connection on the engine stop solenoid. This will prevent fuel flowing to the engine when the engine is turning over.
- 4 Clean dirt from the top of the engine area to prevent contaminants entering the engine.
- 5 Remove the fuel injection pipes from the fuel injectors. (fig. C4665) If the injector pipes are corroded or the pipes twist with the nut when loosening, replace the injection pipe before putting the loader back into service. Cap the open lines and injectors to prevent contamination entering the fuel injection system.
- 6 Remove the fuel transfer lines from the injectors.
- 7 Remove the fuel injectors from each cylinder. Use caution. Do not damage the injector while removing from the cylinder head.
- 8 Connect a compression tester (see Special Tools in Section 8) to the cylinder to be tested. (fig. C179) Be sure to use the correct thread on the adapter screwed into the injector hole.
- 9 Rotate the engine with the starter (200 ~ 300 RPM) 2 ~ 3 complete revolutions. Note the compression reading on the gauge. Repeat the process again to verify the first test reading.
- 10 Continue the compression test and the remaining cylinders keeping written notes of all the registered test readings.
- 11 Compare the compression test readings with the specifications given in Section 7.4, pg. 7-24, Engine Specifications.

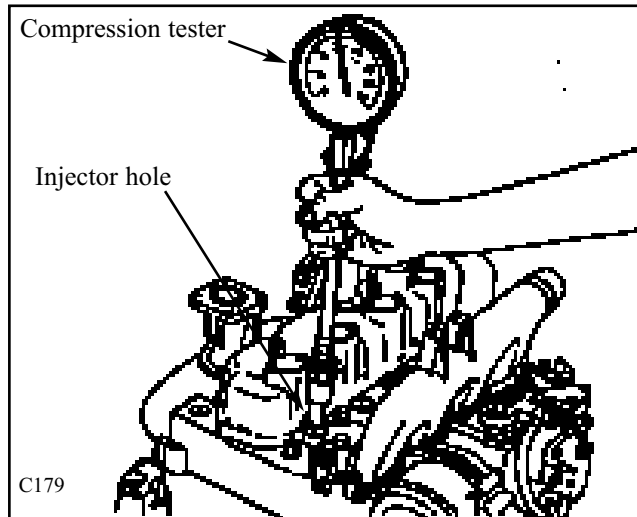
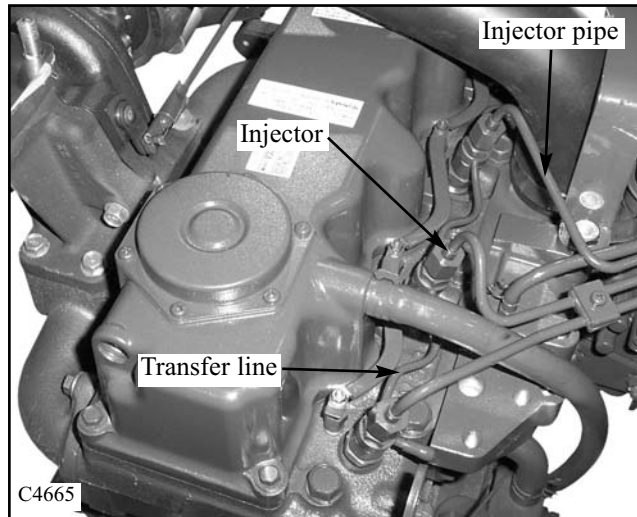

continued...

CYLINDER HEAD 7.2

Compression Testing (cont'd)

If the compression test reading are low, add a small amount of oil, through the injector hole, to the affected cylinder (s). Recheck the compression test readings. If the readings improve from the first test then the piston rings or cylinder bores are likely worn.

If the compression reading does not improve the problem is likely a cylinder head related problem such as valve train, cylinder head gasket, or a bad piston. The cylinder head should be removed for further inspection. See the Kubota Service / Repair Manual P / N 97897-01712 or Thomas P / N 46577.

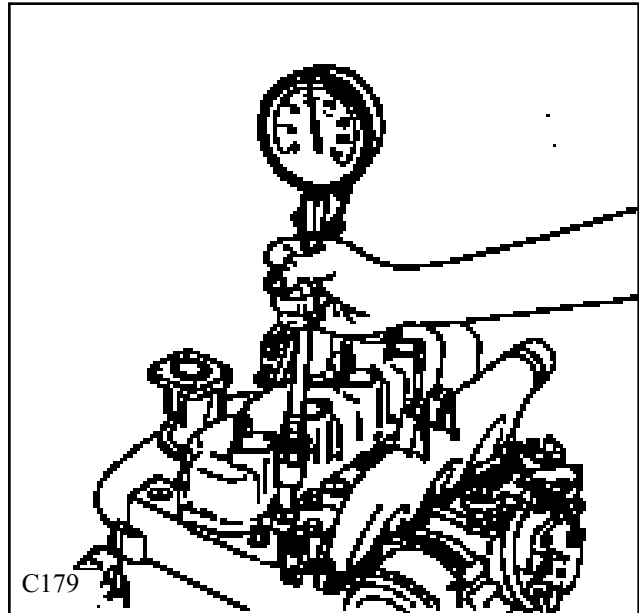

C179

Cylinder Head

After replacement of the engine cylinder head, the proper bolt torquing sequence must be followed. (fig. C578)

Torque the bolts in 3 separate steps, increasing tightness to the specified 98.1 ~ 107.8 Nm (72.3 ~ 79.5 ft / lbs)

Apply oil to the threads of the bolt and to the heads of the bolt where they contact the cylinder head casting.

Always install a new head gasket and oil gallery O- ring when replacing the cylinder head.

After installation, operate the engine for half an hour to bring to full operating temperature. Allow the engine to fully cool and retorque the cylinder head bolts.

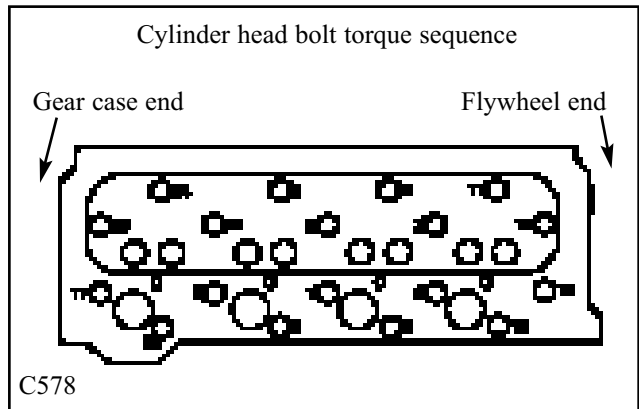

C578

ENGINE REPLACEMENT 7.3

Removal

Move the loader to a level surface. Raise the boom arms, engage the boom supports, apply the parking brake, shut off the engine and remove the ignition key.



WARNING

To prevent personal injury do not work under the boom arms without the boom supports engaged.

- 1 Remove the seat and hydrostatic shield. Open the rear door and radiator / cooler assembly to access the engine compartment. (fig. C3857)
- 2 Shut off the fuel petcock located at the bottom of the right hand fuel tank, inside the engine compartment. (fig. C4683)
- 3 Loosen the fuel line clamp and disconnect the fuel line from the engine. (fig. C4692)
- 4 Disconnect the clamp from the fuel return line from behind the rear fuel injector located at the front of the engine. (fig. C4693) Place the return line higher than the fuel level to prevent fuel spillage.
- 5 Drain the engine oil and coolant. See Section 7.1 Lubrication system and Cooling System.

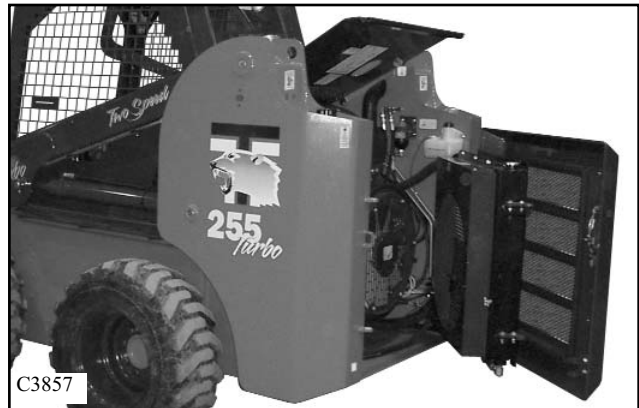

C3857

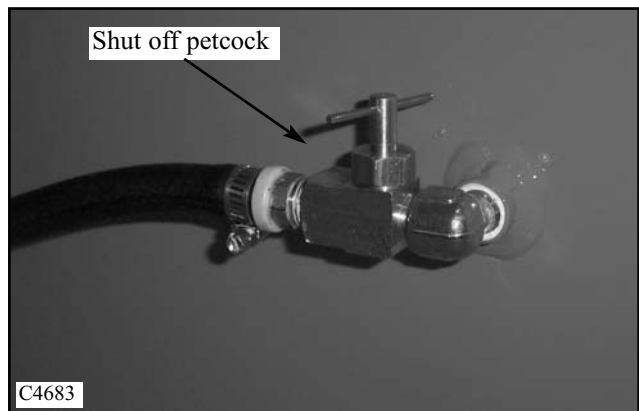

C4683

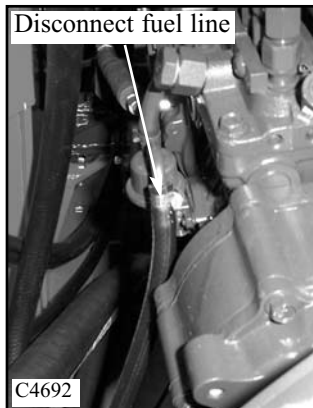

C4692

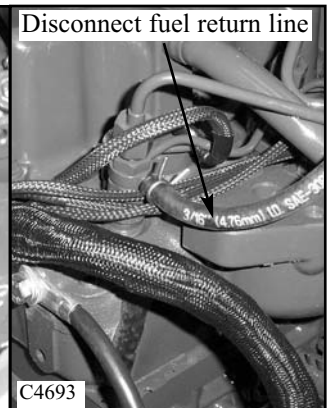

C4693

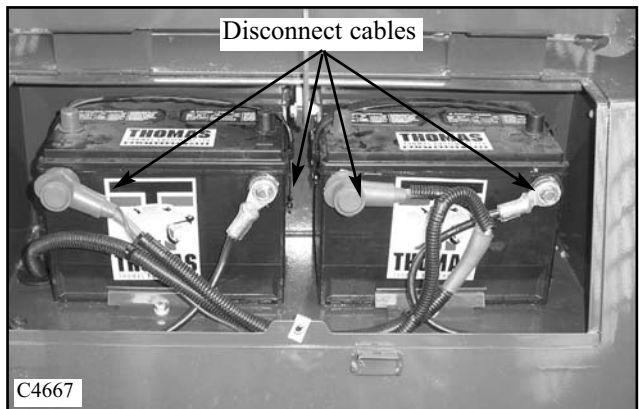

C4667

- 6 Access the battery compartment and disconnect both ground cables from the battery terminals. (fig. C4667) Disconnect the positive cables from the battery. Remove the rubber grommet from the RH corner of the battery compartment. Slide the positive cable through the hole in the corner of the battery box.

7

ENGINE REPLACEMENT 7.3

Removal (cont'd)

7 Disconnect the main engine harness / ROPS harness plug connector. (fig C3576)

8 Unplug the mainframe harness and safety harness from the engine harness.

9 Access the electrical panel located in the engine compartment. Disconnect the wiring to the relays and fuse block. (fig. C3589) Remove the wire clamp on the harness and remove the wire harness from the electrical panel. When reconnecting see section 5-7 page 5-14.

10 Remove the clamps mounting the engine cover to the loader frame. Remove the engine cover to aid the removal of the engine from the engine compartment.

11 Disconnect the air filter restrictor sensor wires located at the front of the air cleaner canister. (fig C4685)

12 Remove the ground wires from the chassis ground bolt located on the RH side of the loader frame. (fig C4675)

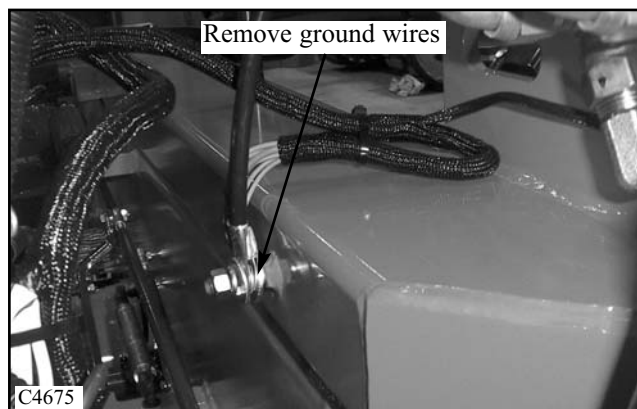
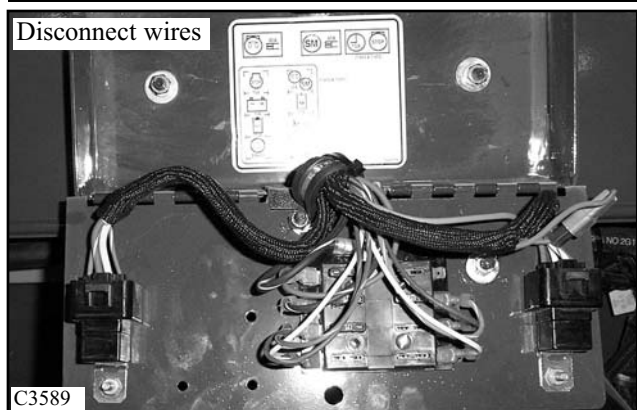
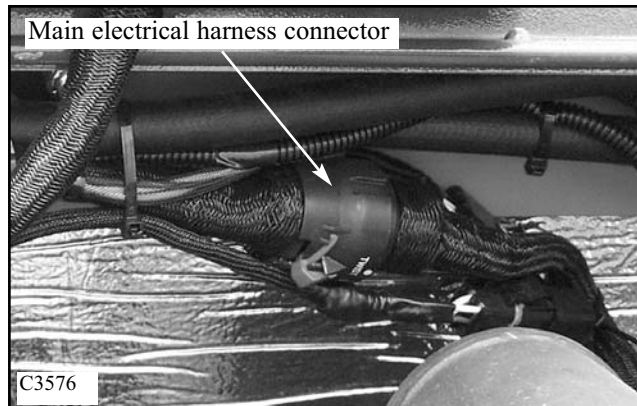

ENGINE REPLACEMENT 7.3

Removal (cont'd)

13 Disconnect the wires going to the fuel level sender in the fuel tank. (fig. C3582)

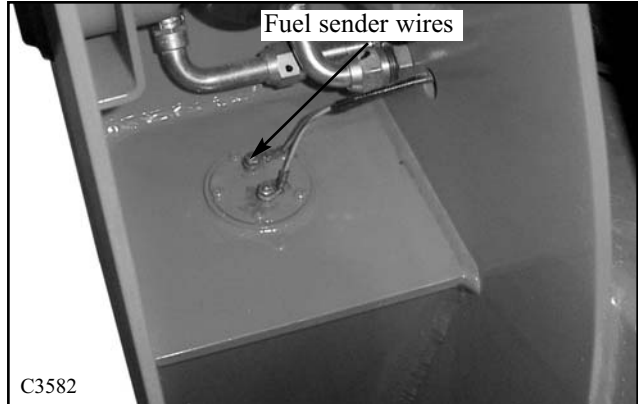

14 Disconnect the ground cable mounted from the engine to the loader frame. This is located at the front of the engine and grounded to the LH frame. (fig. C4694)

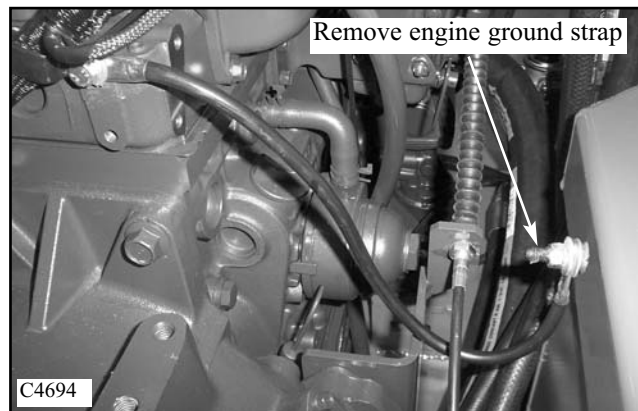

15 Disconnect the hydraulic control valve electrical connections. (fig. C4695) Tag the connections for location to prevent mixing up upon engine replacement.

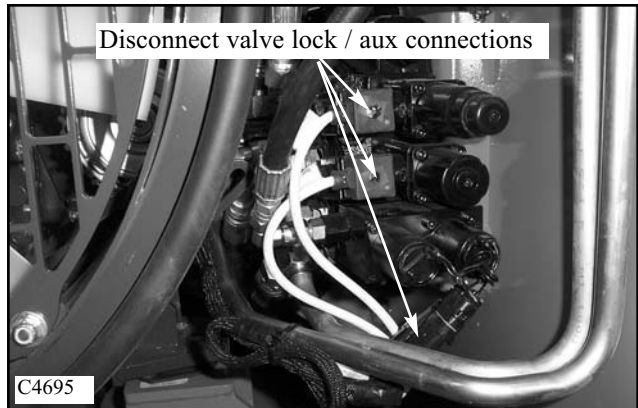

16 Disconnect the hydraulic oil temperature sender located on the left hand oil tank, inside the engine compartment. (fig. C3636)

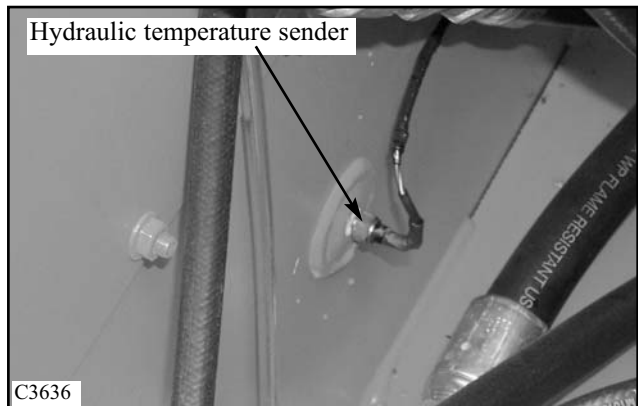

7

ENGINE REPLACEMENT 7.3

Removal (cont'd)

17 Loosen the jam nuts on the cable mounting bracket. Disconnect the throttle cable from the engine by pulling ahead on the throttle pivot end, then turn the pivot end to unhook the ball from the socket. (fig. C4696)

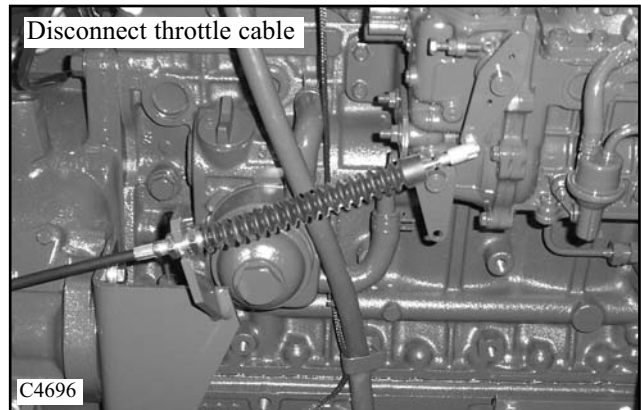

18 Disconnect the hose clamp on the upper radiator hose connected to the thermostat housing.(fig C4668) Take note of the routing on the hose for reassembly

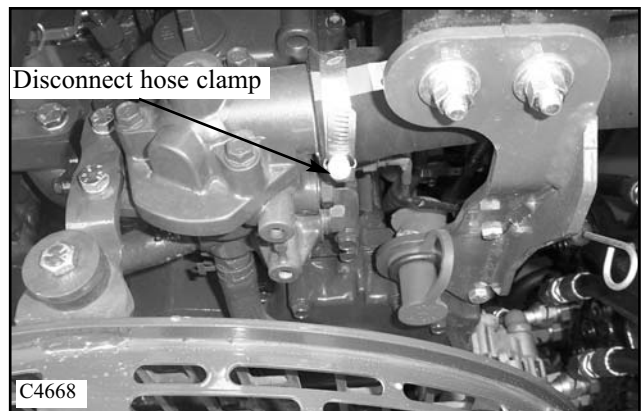

19 Disconnect the hose clamp on the lower radiator hose connected to the water pump outlet. (fig. C4697) Take note of the routing on the hose for reassembly.

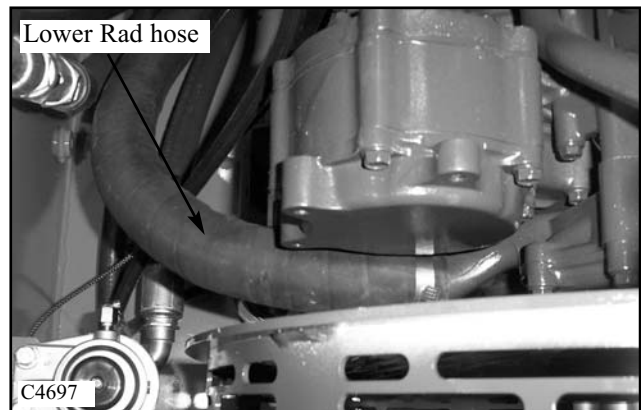

20 Attach a vacuum system to the hydraulic oil reservoir filler location, (fig.C4604) Drain the oil reservoir if a vacuum is not available. Seal the threads on the drain plug with teflon tape or a liquid form of pipe sealant before re-installing.

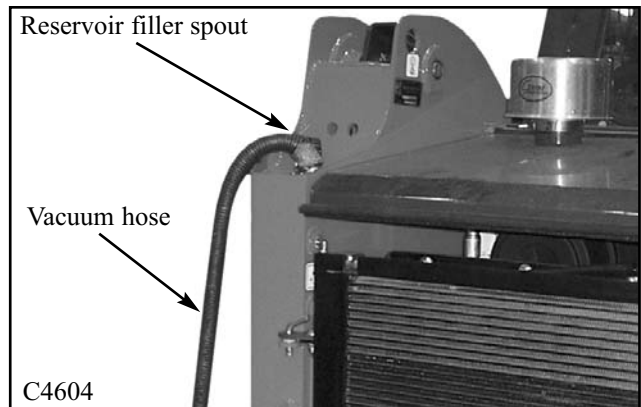

ENGINE REPLACEMENT 7.3

Removal (cont'd)

21 Remove the pintal levers from the manual displacement levers on the pump. Remove the steering lever linkage from the control levers. (fig. C4631) Refer to section 4 for removal and replacement information.

IMPORTANT

When making repairs to the hydraulic system, keep the work area and parts clean. Use caps and plugs on all open lines and ports.

22 Disconnect both hydraulic hoses to the gear pump. (fig. C4605) Mark hose and fitting location if necessary to ease re-assembly. Upon re-assembly, torque the hydraulic fittings and hoses as outlined in the Torque Chart in Section 2.13. Remove the fittings from the gear pump and keep the fittings in a clean area. Inspect fittings and o-rings for damage, replace as required. Cap all open lines and ports.

23 Remove the 2 hoses from the tee fitting located on the charge pressure gauge port of the pump. (fig. C4626) Mark the hoses if necessary to ease re-assembly. Remove the tee fitting from the pump, and keep the tee fitting in a clean area. Inspect the fitting and o-ring for damage, replace as required. Cap all open ports and lines.

24 Remove the 2 anti-cavitation hoses from the fittings located on the top 2 system pressure gauge port of the pump. (fig. C4626) Mark the hoses if necessary to ease re-assembly. Remove the fittings from the pump and keep in a clean area. Inspect fittings and o-rings for damage, replace as required. cap all open ports and lines.

25 Remove the hoses from the charge pump inlet and the 2 high pressure hoses for the LH torque motor. (fig. C4632) Mark the hoses if necessary to ease re-assembly. Remove the fittings from the pump and keep in a clean area. Inspect the fittings and o-ring for damage, replace as required. Cap all open ports and lines.

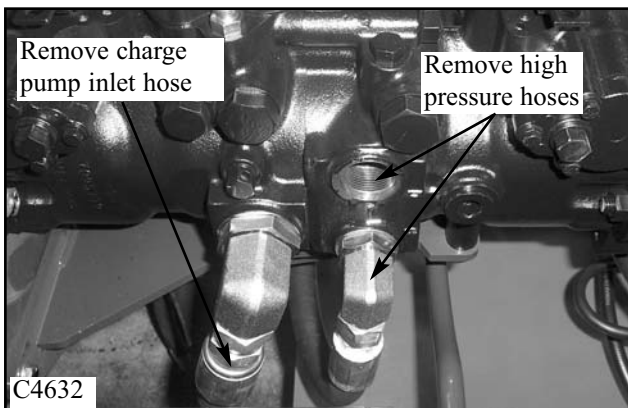
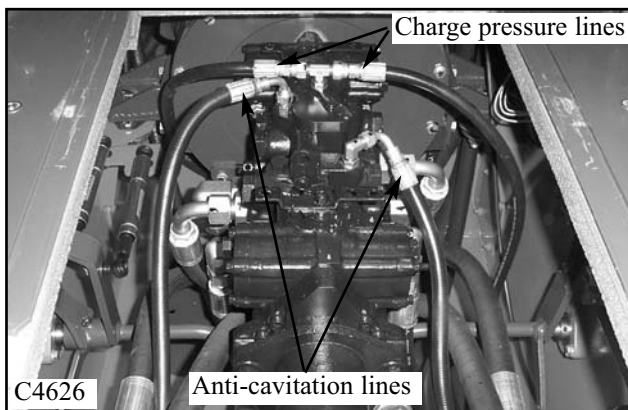
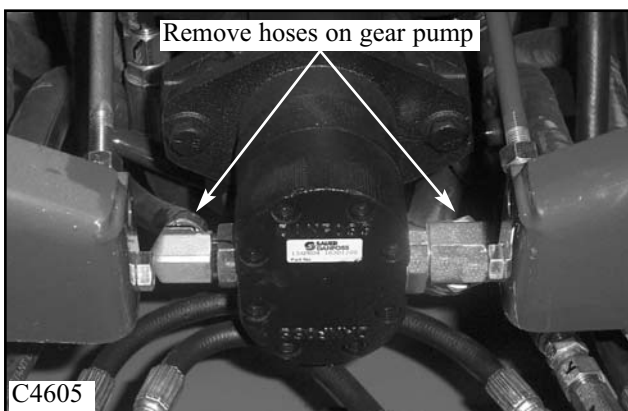
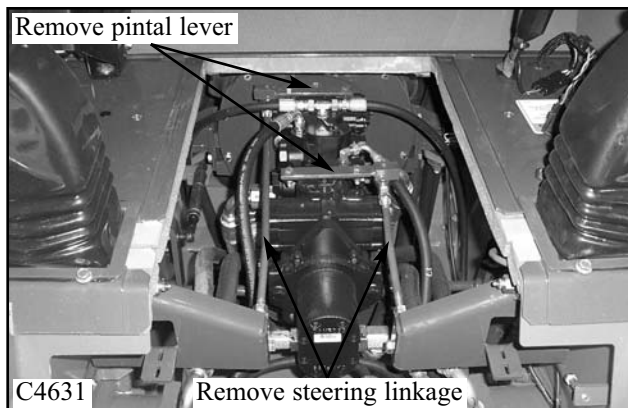

7

ENGINE REPLACEMENT 7.3

Removal (cont'd)

26 Remove the hoses from the case drain and the 2 high pressure hoses for the RH torque. (fig. C4633) Mark the hoses if necessary to ease re-assembly. Remove the fitting from the pump and keep in a clean area. Inspect the fittings and o-ring for damage, replace as required. Cap all open ports and lines.

27 Remove the 4 bolts retaining the engine to the rubber composite mounting isolators. (fig. C3638)

28 Use suitable lifting points when connecting the lifting device to the engine. Hoist the engine up slightly, and gently pull the engine away from the loader frame. (fig. C4698) Check for any wiring and hydraulic hoses that may be connected or snagged to the engine, as you retrieve it from the compartment.

29 Set the engine on a suitable workbench that is capable of supporting the weight of the engine and the sides of the engine so it does not fall over. Some disassembly is required. (fig. C4699)

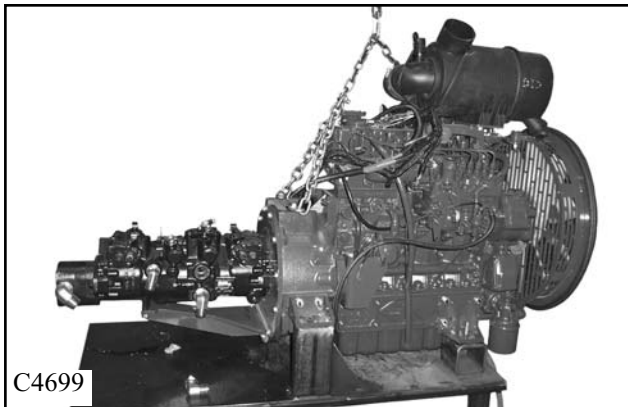
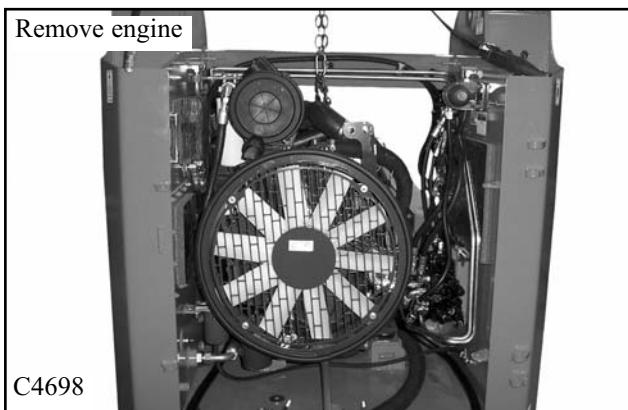
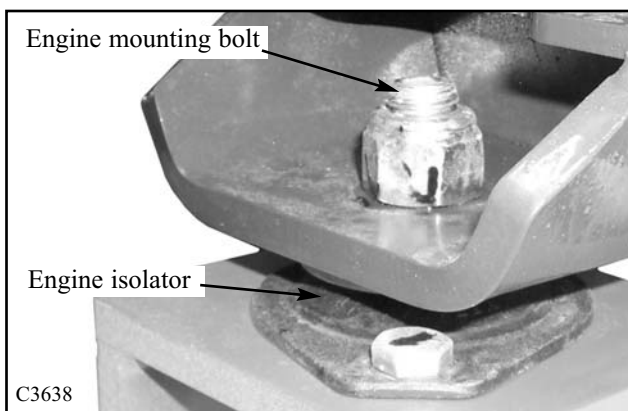
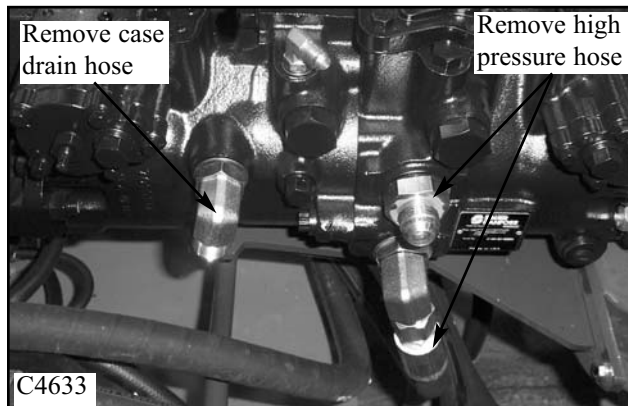

CAUTION

To prevent possible personal injury, do not attempt to lift heavy objects without assistance.



CAUTION

Use a chain size of 3/8" grade 40 minimum when replacing the engine

ENGINE REPLACEMENT 7.3

Removal (cont'd)

30 Remove the 4 mounting bolts on the pump support. (fig. C4700) Torque the mounting bolts to 80 ft lbs (108 Nm) for reassembly. Connect a overhead hoist to the lifting lug on the tandem pump. Remove the tandem pump from the mounting location. Place the tandem in a clean area to prevent contamination until reassembly.

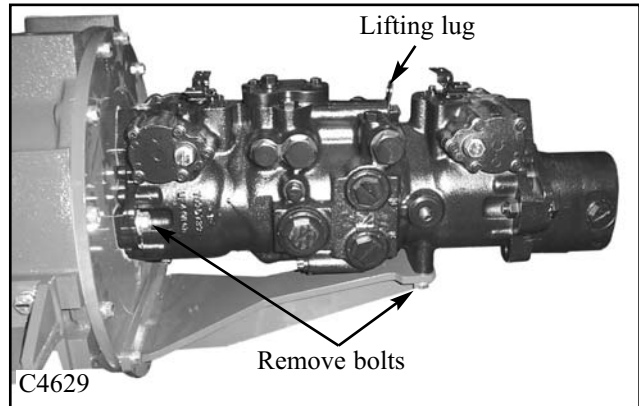

31 Remove the bolts fastening the rear and bottom pump support to the bell housing. Remove the pump supports for the engine. Remove the bolts and adapter coupling from the fly wheel on the engine. (fig. C4701) Torque the bolts to 30 ft lbs (Nm) for reassembly.

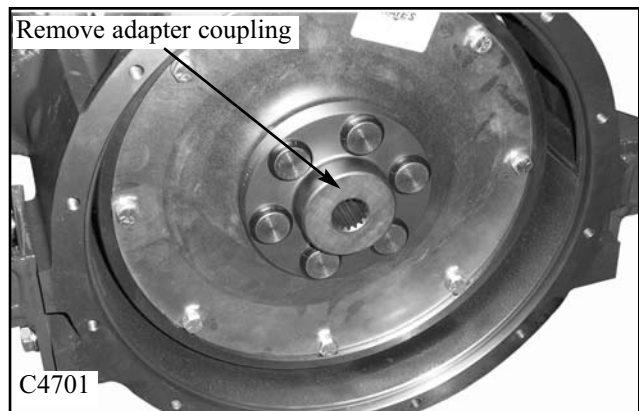

32 Remove the bolts for the engine mounts assembly. (fig. C4702) Apply loctite 242 (blue) to the threads of the engine mounting bolts for reassembly. Torque to 80 ft lbs (Nm) for reassembly. Remove the 4 engine mount assembly from the engine.

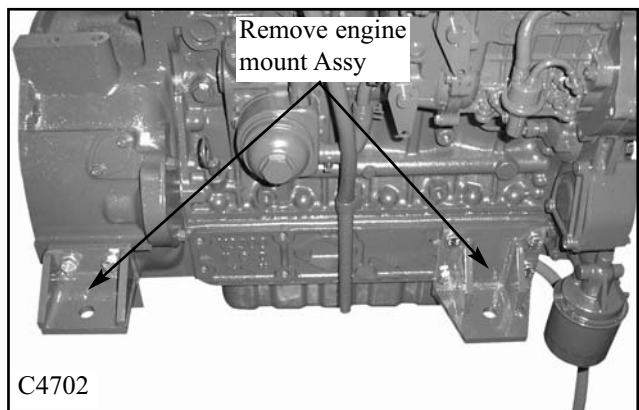

33 Remove the bolts for the rear muffler support. Torque to 32 ft lbs (Nm) for reassembly. Remove the 4 nuts on the front flange of the muffler. (fig. C4703) Remove the muffler from the engine.

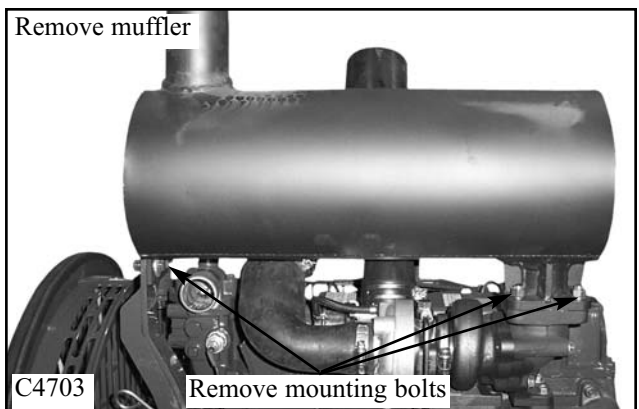

7

ENGINE REPLACEMENT 7.3

Removal (cont'd)

34 Remove the 4 bolts in the bottom of the air cleaner canister. (fig. C4700) Remove the air cleaner canister. Remove the 4 mounting bolts in the air cleaner canister mount. Apply loctite 242 (blue) to the threads of the mounting bolts for reassembly.

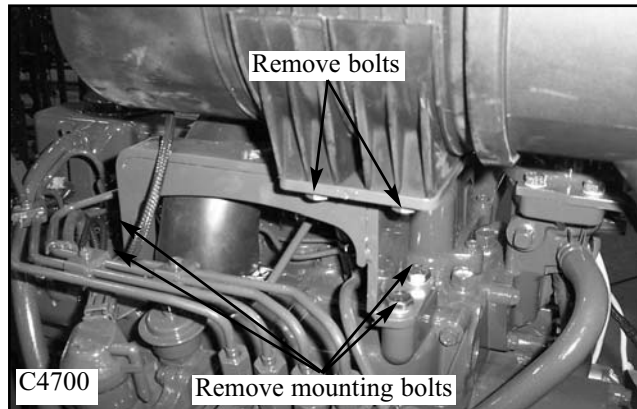

35 Disconnect the electrical cable from the boosting lug terminal. (fig. C4668)

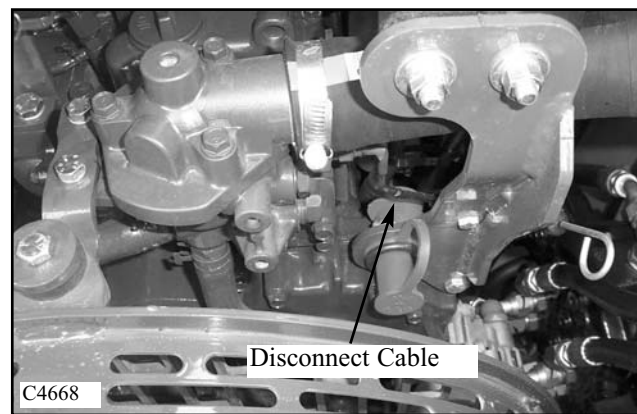

36 Unplug the wire for the water temperature sensor. (fig. C4704) Remove the bolt retaining the clamp for the dip stick and water temperature wire. Remove the rear muffler support from the mounting location on the engine.

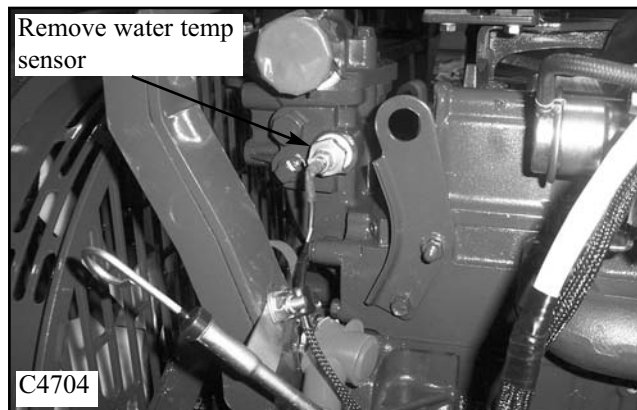

37 Disconnect the positive cable and wire harness coming from the positive post on the starter. Disconnect the wire from the single terminal on the starter. (fig. C4705) Note all wire locations and routing for reassembly.

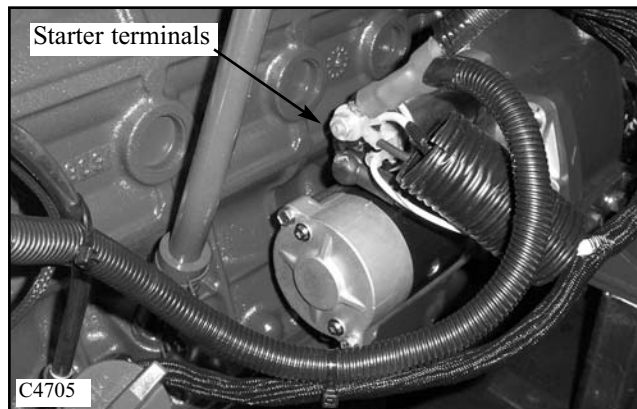

7

ENGINE REPLACEMENT 7.3

Removal (cont'd)

38 Disconnect the wires to the alternator. (fig. C4706) Note the connection and routing for reassembly. Remove the wire from the engine oil sensor. Remove the sensor.

39 Disconnect the wires to the fuel shut off solenoid. Remove the engine harness from the engine. Note the routing of the harness. Remove any clamps that support the harness to the engine.

40 Remove the bolts from the fan guard brace. Loosen the bolt for the shroud isolator. Remove the snubbing washer, bolt, lock nut and isolator from the fan guard brace. (fig. C4707) Torque to 32 ft lbs (Nm) for reassembly

41 Remove the lock nuts, snubbing washers and isolators on the standoff rods located at the bottom of the engine shroud.

42 Loosen the alternator bolts and allow the tension on the fan belt to loosen off. Remove the fan bolts and spacer from the engine pulley. Remove the cooling fan and shroud from the engine. (fig. C4708) Remove the standoff rods from the engine. Apply Loctite 242 (blue) to the threads of the standoff rods. Torque 32 ft lbs (Nm) for reassembly.

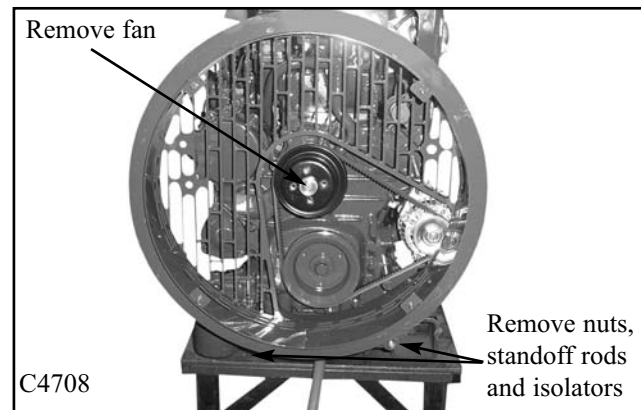
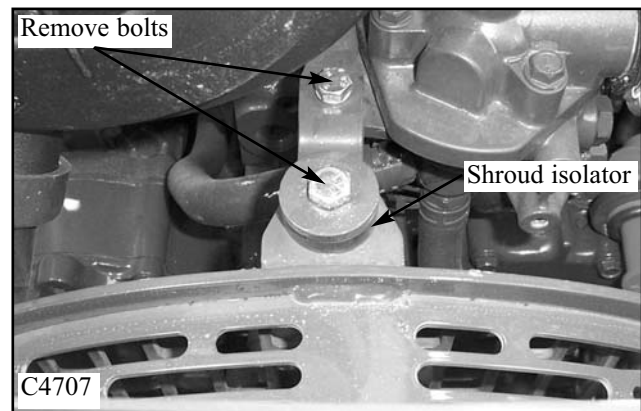
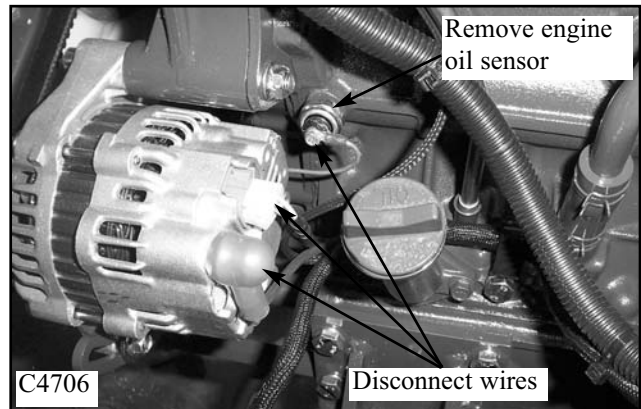

7

ENGINE REPLACEMENT 7.3

Installation

If the engine is being replaced with a new assembly, the engine will require some preparation.

- 1 Remove the protective rust preventative coating from the flywheel. Use a solvent to remove. The flywheel must be cleaned to the surface metal.
- 2 Paint must be removed from the engine block where the ground strap is attach to the front of the engine. This will provide proper grounding of the engine with the loader chassis. (fig. C4190)
- 3 Check the engine mounting isolators in the loader frame. (fig. C4709) Make sure the isolators are not separating or the composite is deteriorated in any way. Replace engine isolators as required.
- 4 Replace the engine in reverse order. Remember to torque the mounting bolts to 80 ft lbs (109 Nm) (fig. C3638)
- 5 The start up must be made with the loader raised securely from the ground. Changing the pumps and steering control linkages has affected the neutral adjustment. Failure to raise the loader clear of the ground may result in the loader engaging in motion and possibly causing serious injury.



WARNING

This start-up procedure must be made with the loader securely raised off the ground.

- 6 Follow the pump and engine start up procedures as listed in section 2-8 page 2-16 and section 7-1 page 7-5.
- 7 Start the loader and check for leaks. Make repairs as necessary and replenish the hydraulic oil reservoir. Never use your hands to check for hydraulic leaks.



WARNING

To prevent personal injury never make repairs to the hydraulic system while the engine is operating.

- 8 Check the engine rpm and adjust as required.
- 9 Make adjustments to the steering controls as required. Follow the procedures for the control adjustments in section 4.

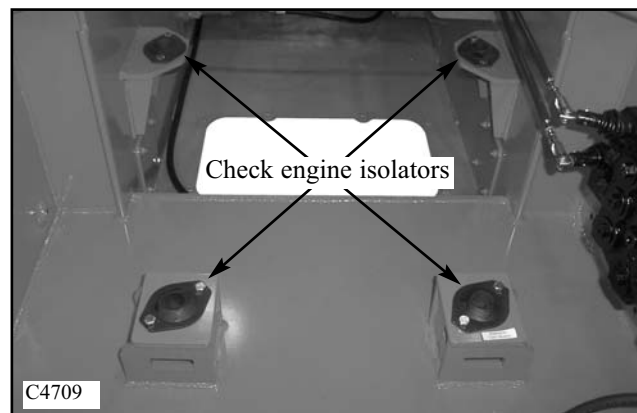
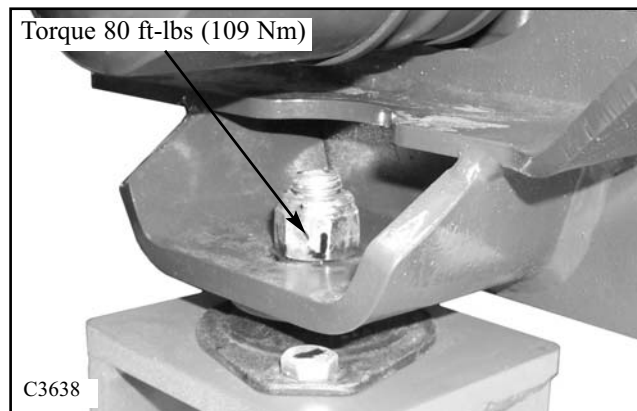
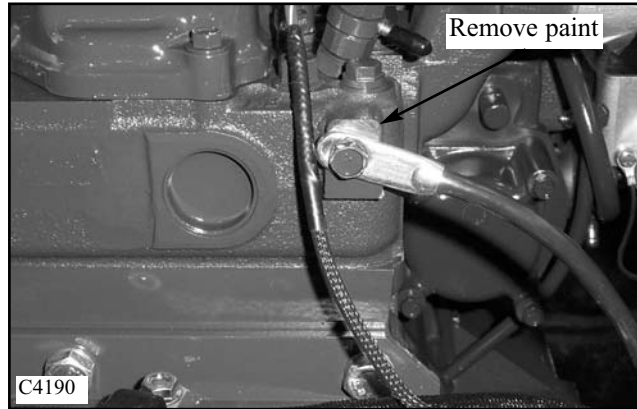

ENGINE SPECIFICATIONS T250/255 7.4

Make and model	Kubota V3300-T-B
Type.....	Vertical , In Line, 4 Cycle
Number of cylinders.....	4
Displacement	202.5 in ³ (331.8 cm ³)
Cylinder bore.....	98 mm (3.86 inches)
Factory Specification:	98 ~ 98.022mm. (3.8582 ~ 3.8591 inches)
Allowable Limit:	98 ~ 98.15 mm. (3.86 ~ 3.8642 inches)
Stroke.....	110 mm (4.33 inches)
Maximum engine speed (no load)	2750 RPM
Maximum engine speed (CE).....	2500 RPM
Low idle setting.....	1300RPM
Cooling system	Liquid
Cold starting aid.....	Glow plug in combustion chamber
Horsepower (Gross).....	87.4
Power (ISO 9249 Net Power).....	61.9kW @ 2700 RPM
Max Torque	205 ft / lbs (280 Nm @ 1400 RPM)
Compression ratio	21: 8
Engine compression.....	40 kgf / cm ² (569 psi)
.....	Service limit: 30.5 kgf / cm ² (434 psi) 10 % variance among cylinders
Firing order (viewed from gear case end).....	1 - 3 - 4 - 2
Fuel injection pump.....	Bosch type mini pump
Fuel injection timing	16° BTDC (0.279 Rad)
Injector working pressure	140 - 150 kgf / cm ² (1991 ~ 2133 psi)
Direction of rotation (viewed from flywheel end).....	Counter - clockwise
Location of timing marks	N / A
Valve clearance, (cold).....	0.23 ~ 0.27 mm (0.0091 ~ 0.011 in)
Valve seat angle.....	Intake 1.047 Rad (60°)
.....	Exhaust 0.785 Rad (45°)
Valve seat width.....	Intake 2.12mm (0.0835 in)
.....	Exhaust 2.12mm (0.0835 in)
Valve face angle	Intake 1.047 Rad (60°)
.....	Exhaust 0.785 Rad (45°)
Valve recessing.....	Protrusion 0.05mm (0.0020 in)
.....	Recess 0.15mm (0.0059 in)
Fuel type	Diesel No. 2
Fuel filter.....	Single spin on type
Air cleaner	Dual dry cartridge elements (primary and secondary) with restriction indicator
Oil filter.....	Single spin on type
Engine oil pressure	@ Idle speed 98 Kpa (14 psi) minimum
.....	@ Rated speed 245 Kpa (36 psi) minimum
Oil pressure switch.....	Closes @ 49 Kpa (7 psi)
Engine oil capacity with filter.....	13.2 (3.43 gal)
Oil type	5W40API CF
Cooling system capacity	16 l (4.2 gal.)
Radiator cap pressure setting	110 kPa (16 psi)
Thermostat rating.....	Fully open 90°C (194°F)

**For complete engine service repair manual:
Order P / N 46577 (Kubota P / N 97897-01712) from your nearest dealer.**

TROUBLE SHOOTING 7.5

Symptom	Cause	Remedy
Engine does not start	No fuel	Replenish fuel
	Air in the fuel	Vent air
	Water in the fuel	Change fuel and repair or replace fuel system
	Fuel pipe clogged	Clean
	Fuel filter clogged	Clean or change
	Excessively high viscosity of fuel or engine oil at low temperature	Use the specified fuel or engine oil
	Fuel with low octane number	Use the specified fuel
	Fuel leak due to loose injection pipe retaining nut	Tighten nut
	Incorrect injection timing	Adjust
	Fuel cam shaft worn	Replace
	Injection nozzle clogged	Clean
	Injection pump malfunctioning	Repair or replace
	Seizure of crankshaft, camshaft, piston, cylinder liner or bearing	Repair or replace
	Compression leak from cylinder	Replace head gasket, tighten cylinder head bolt, glow plug and nozzle holder
	Improper valve timing	Correct or replace timing gear
Piston ring and liner worn	Replace	
Excessive valve clearance	Adjust	
Starter does not run	Battery discharged	Charge
	Starter malfunctioning	Repair or replace
	Key switch malfunctioning	Repair or replace
	Wiring disconnected	Connect
Engine revolution is not smooth	Fuel filter clogged or dirty	Clean or change
	Air cleaner clogged	Clean or change
	Fuel leak due to loose injection pipe retaining nut	Tighten nut
	Injection pump malfunctioning	Repair or replace
	Incorrect nozzle opening pressure	Adjust
	Injection nozzle stuck or clogged	Repair or replace
	Fuel overflow pipe clogged	Clean
Governor malfunctioning	Repair	
Either white or blue exhaust gas is observed	Excessive engine oil	Reduce to the specified level
	Low grade fuel used	Used the specified fuel
	Fuel filter clogged	Adjust
	Air cleaner clogged	Adjust top clearance
Either black or dark gray exhaust gas is observed	Overload	Lessen the load
	Low grade fuel used	Use the specified fuel
	Fuel filter clogged	Clean or change
	Air cleaner clogged	Clean or change



TROUBLE SHOOTING 7.5

SYMPTOM	PROBABLE CAUSE	SOLUTION
Excessive lubricant oil consumption	Piston rings gap facing the same direction	Shift gap direction
	Oil ring worn or stuck	Replace
	Piston ring groove worn	Replace
	Valve stem and guide worn	Replace
	Crankshaft bearing and crank pin bearing worn	Replace
Fuel mixed into lubricant oil	Injection pump's plunger worn	Replace pump element or pump
	Injection pump broken	Replace
Water mixed into lubricant oil	Head gasket defective	Replace
	Cylinder block or cylinder head flawed	Replace
Low oil pressure	Engine oil insufficient	Replenish
	Oil strainer clogged	Clean
	Relief valve stuck with dirt	Clean
	Relief valve spring weakened or broken	Replace
	Excessive oil clearance of crankshaft bearing	Replace
	Excessive oil clearance of crank pin bearing	Replace
	Excessive oil clearance of rocker arm bearing	Replace
	Oil passage clogged	Clean
	Oil pump defective	Replace
	Different type of oil	Use the specified oil type
High oil pressure	Relief valve defective	Replace
	Engine oil insufficient	Replenish
Engine overheated	Fan belt broken or elongated	Change or adjust
	Cooling water insufficient	Replenish
	Radiator net and radiator fin clogged with dust	Clean
	Inside of radiator corroded	Clean or replace
	Cooling water flow route corroded	Clean or replace
	Radiator cap defective	Replace
	Overload running	Loosen the load
	Head gasket defective	Replace
	Incorrect injection timing	Adjust
Deficient output	Unsuitable fuel used	Use the specified fuel
	Incorrect injection timing	Adjust
	Engine's moving parts seem to be seizing	Repair or replace
	Uneven fuel injection	Repair or replace injection pump
	Deficient nozzle injection	Repair or replace nozzle
	Compression leak	Replace head gasket, tighten cylinder head bolt, glow plug and nozzle holder
Battery quickly discharges	Battery electrolyte insufficient	Replenish distilled water
	Fan belt slips	Adjust belt tension or change
	Wiring disconnected	Connect
	Rectifier defective	Replace
	Alternator defective	Replace
	Battery defective	Change

7

SECTION 8

MAINTENANCE & SPECIFICATIONS

Maintenance	8.1
Preventative Maintenance Schedule.....	pg. 8-2
Service Access	pg. 8-3
Daily Service	pg. 8-4
50 Hour Service	pg. 8-5 ~ 6

Trouble Shooting	8.2
Hydrostatic Drive	pg. 8-7
Final Drive.....	pg. 8-7
Parking Brake	pg. 8-7
Hydraulic System	pg. 8-8
Control Levers	pg. 8-9
Electrical.....	pg. 8-9
Diesel Engine	pg. 8-10 ~ 11

Special Tools	8.3
Descriptions & P / N's	pg. 8-12 ~ 15

Specifications	8.4
Loader Specifications.....	pg. 8-17 ~ 19
Torque Chart / Specifications	pg. 8-20

Decals	8.5
Locations & P / N's.....	pg. 8-21 ~ 23

MAINTENANCE 8.1

8.1 Preventative Maintenance Service Schedule

ITEM	SERVICE REQUIRED	8 HOURS	50 HOURS	150 HOURS	300 HOURS	1000 HOURS
Engine Oil	Check level. If necessary add 5W40 API Classification CF oil.					
Radiator	Check level and add if necessary. Fill with 50% mixture of ethylene glycol and water. Check cooling fins for dirt. If necessary blow out with compressed air. Check rubber seal around radiator baffle.					
Hydraulic Oil	Check level and add if necessary add 10W30 API Classification SJ (-20°C to 35°C) or 20W50 API Classification SJ (-10°C to 45°C) oil.					
Oil Cooler	Check cooling fins for obstruction. Clean with compressed air or water.					
Air Cleaner	Empty dust cap. Check condition indicator and service or replace element as required.					
Tires and Wheels	Check for low pressure or tire damage. Inflate 10.00 x 16.5 to 45-50 psi (310-345 kPa). Check wheel nut torque 100-110 ft lbs (136-149 Nm)					
Safety Equipment	Check all safety equipment for proper operation and condition (seat belt, lift arm supports, seat bar, parking brake, quick-tach lock, shields, safety treads, front shield, cab side screens). Repair or replace safety treads if necessary.					
Final Drive	Check chain and sprocket condition. Check every 150 hrs.					
Decals	Check for damaged or missing safety and instruction decals. See Section 8.5. Replace decals as required.					
Lubrication	Grease all hinge pin fittings until excess shows.					
Engine Oil	Replace engine oil. Use 5W40 API Classification CF oil. Initial change only.					
Engine Oil Filter	Change engine oil filter element. Initial change only.					
Hydraulic Oil	Change hydraulic oil filter elements. Initial change only.					
Muffler	Check the muffler for carbon buildup and plugging. Clean if necessary. Check every 100 hours.					
Safety System Linkages And Springs	Check and if necessary adjust. Lubricate lock springs, shaft and linkage.					
50 Hour Service	Perform complete 50 hour service.					
Engine Oil	Replace engine oil (initial change already made). Use 5W40 API Classification CF oil. Replace every 150 hours.					
Engine Oil Filter	Replace engine oil filter. Replace every 150 hours.					
Hydraulic Oil Filter	Replace hydraulic oil filter elements					
Preventative Maintenance Service Check	It is recommended as a preventative maintenance that the 50 hour service be repeated every 150 hours after the initial 50 hour service.					



Note: For complete engine service details refer to Section 7 of this manual. If further information is required refer to the engine manufacturers service manual.

MAINTENANCE 8.1



WARNING

To avoid personal injury, service repairs must be performed by an authorized Thomas dealer.

8.1.2 SERVICE ACCESS

1. 2A Boom Support

For safety while performing regular service or maintenance work, the loader is equipped with boom support pins. The boom support pins when extended prevent the boom arms from dropping if hydraulic pressure is relieved or the hydraulic controls are accidentally cycled.

IMPORTANT

Fully retract boom support pins before raising or lowering boom arms.

To operate the boom support, first remove any bucket or attachment from the quick - tach; raise the boom arms to full height. Raise the boom support handle (fig. C693) up and push out toward boom arms to extend the boom support pins (fig. C694) Slowly lower the boom arms down on to the pins.



WARNING

To avoid personal injury: Do not leave boom arms up unless the boom supports are engaged.

1. 2B Seat Removal

The seat and seat plate can be removed to provide access to the controls, hydraulic and hydrostatic components. To remove the seat assembly, remove the fasteners located at the front of the seat. DISCONNECT THE ELECTRICAL PLUG! Lift the seat assembly out of the machine. When installing the seat, be sure the seat plate is locked in place at the rear.

The hydrostatic shield can be by removing the fasteners (fig.C3557).

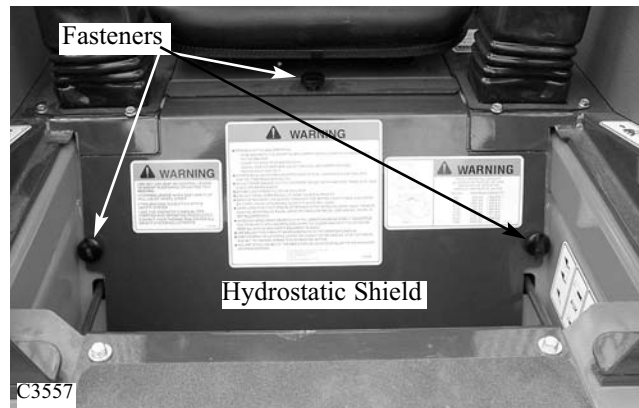
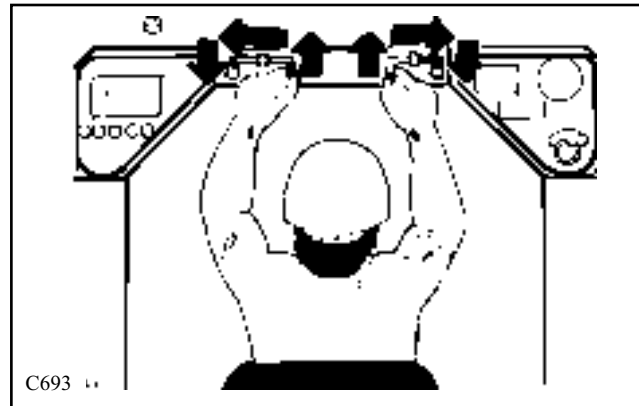

MAINTENANCE 8.1

8.1.3 DAILY SERVICE CHECK

1.3A Radiator Service

With the engine cool remove the radiator cap and check the coolant level. If adding coolant is required fill with a 50% mixture of ethylene glycol and water for cold weather protection.

The radiator cooling fins must be kept free of debris, otherwise overheating of the engine will occur. Inspect the radiator cooling fins for damage or buildup of debris. Repair any damage and if necessary flush the radiator with compressed air to remove debris.

1.3B Hydraulic Oil Level

Check the oil level with the machine on a level surface with the lift arms down and the bucket flat on the ground. Open the rear door and check the oil level sight glass (See Section 1). If oil is apparent the oil level is satisfactory.

If it necessary to add oil, remove the reservoir cap located at the top of the oil reservoir and add oil until oil appears in the oil level sight glass.

Use a good quality 10W30 oil which meets the API classification SJ only.

1.3C Air Cleaner

The loader is equipped with an air cleaner restriction warning lamp.

Should this lamp illuminate, shut off the engine and determine the cause. Possible plugged air filter.

Check that all hose clamps are tight and the hose is undamaged. Check the vacuator valve for damage.

1.3D Tires and Wheel Nuts

Inspect tires for wear or damage. Check and inflate tires to correct pressure:

12.5 x 16.545-50 psi (310 ~ 345 kPa)

To prevent shearing of the wheel studs and rim damage check wheel nuts for proper torque 100 -110 ft lbs (136 - 149 Nm) daily. After changing a rim, check wheel nuts hourly, until the reading stabilizes.

1.3E Safety Equipment

Check all safety equipment for proper operation and condition - seat belt, boom support, seat bar, foot pedal lock, parking brake, quick tach lock, shields and safety treads. Lubricate all linkages, springs and pivot points with a silicone based lubricant. Repair or replace if necessary.

1.3F Decals

Check the condition of all safety and instruction decals. Replace any damaged or missing decals. Refer to section 8.3 for decal description and locations.

1.3G Lubrication

There are sixteen grease fittings located on the loader that require lubrication every eight hours. (See Section 6) Lubricate with a good quality multi-purpose lithium based grease. Apply grease until excess shows.

Refer to the service schedule for complete service details. the sixteen lubrication points are:

- Rear Boom Pivots (2)
- Boom Cylinder Bushings (4)
- Bucket Cylinder Bushings (4)
- Boom Supports (2)
- Quick - Tach Pivot and Lock Pins (4)

1.3H Oil Cooler Service

The oil cooler fins must be kept free of debris otherwise over heating of the hydraulic oil will occur. Check the cooler and if necessary remove debris by flushing with compressed air and / or water.

1.3J Engine Oil Level

To check the oil level, stop the engine with the loader on level ground, open the rear door and remove the dipstick.

Keep the oil level between the full and low mark of the dipstick (See Section 7). Do not fill above the full mark – use 5W40 API classification CF oil.

MAINTENANCE 8.1

8.1.4 50 HOUR SERVICE CHECK

The following service check is to be performed by your dealer after the first 50 hours of operation.

1 Engine

1.1 Oil Filter:

Change the engine oil filter. Use only original replacement parts. Refer to section 7 for installation details. Change the oil filter every 150 hours thereafter.

1.2 Engine Oil:

Change the engine oil. Use only 5W40 API classification CF oil. Refer to section 7 for procedure. Change engine oil every 150 hours thereafter.

1.3 Coolant Level:

Check that the coolant is to the proper level. The cooling system is filled with a 50% mixture of ethylene glycol and water.

1.4 Radiator for Leakage and Dirt:

If necessary flush the radiator with compressed air and / or water. (40 psi [27 kPa] max) Dirt buildup on the radiator cooling fins can cause both engine and hydraulic system overheating. Check rubber gasket on radiator to door baffle.

1.5 Fan Belt Tension and Condition:

Check fan belt for cuts or wear, if necessary replace. Check tension and adjust as shown in section 7.

1.6 Fuel System for Leaks:

Make a visual inspection of fuel system for leaks and potential hazards such as fuel line(s) touching exhaust manifold, flywheel, etc. Replace fuel filter every 400 hours.

1.7 Air Intake and Cleaner System:

Follow the manufacturers inspection procedures. Check that the filter indicator is not indicating that filter service is required.

1.8 Exhaust System:

Visually inspect the exhaust system and ensure all clamps are secure and the manifold bolts/nuts are tight. Check muffler for carbon and soot build up and plugging. If necessary clean. Inspect for exhaust leaks.

1.9 Engine Speed:

Check and if necessary adjust engine rpm. Maximum no load high idle: 2750 rpm.

2 Hydraulic/Hydrostatic

2.1 Hydraulic Oil Filter:

Change the hydraulic oil filter. Change the hydraulic filter every 150 hours after the initial change. Lubricate the filter cartridge seal with system fluid.

2.2 Hydraulic Oil Level:

If oil is visible in the oil level sight glass the level is satisfactory.

If additional oil is required use only 10W30 API classification SJ oil. Fill to the line marked next to the sight gauge.

2.3 Hoses and Pipes:

Make a visual inspection of all hydraulic lines and fittings for leaks. Check that steel lines do not touch one another and clamps are tight.

2.4 Cylinders:

Inspect cylinders for leaks. Extend cylinders and check for rod damage.

2.5 Hydraulic Functions:

Check that the following operate properly: control valve float position, auxiliary hydraulic detent, hydraulic cylinders.

2.6 Pumps & Motors, Leakage:

Inspect pumps and motors for leaks.

2.7 Oil Cooler:

Inspect the oil cooler for leaks, fin damage or clogged with dirt. If necessary flush fins with compressed air and / or water.



WARNING

To avoid personal injury: never repair or tighten hydraulic hoses or fittings with the engine running or the system under pressure.

8

MAINTENANCE 8.1

3 Final Drive

- 3.1 Oil Level:
Check lubricating oil level. If necessary add 10W30 API classification SJ oil.
- 3.2 Drive Chain Condition:
Check drive chains for any sign of wear or damage. Check lubrication oil in housing for signs of contamination.
- 3.3 Hydrostatic Motor Mounting Bolts:
Check torque 100 ~ 110 ft lbs (136 ~ 150 Nm)
- 3.4 Axle Bearing End Play:
Axle bearings are pre - loaded and must have no end play. Inspect and adjust if necessary.

4 Controls and Safety Equipment

- 4.1 Control Levers, Operation and Linkage:
Check that the steering levers operate freely without binding, they return to neutral when released and the machine travels in a straight line with both levers in forward position.
- 4.2 Hydraulic Controls, Operation and Linkage:
Check that the hydraulic controls operate freely without binding. Before leaving the operator's seat, ensure the controls are locked, raise the safety bar and unbuckle the seat belt. Lubricate or replace as necessary linkage.
- 4.3 Engine Throttle Control:
Check that the throttle control operates freely without binding or slackening off due to vibration. Check throttle travel to ensure full engagement of high and low engine idle settings.
- 4.4 Parking Brake:
Check that the parking brake engages and completely disengages. The park brake automatically engages with seat bar up.
- 4.5 Boom Supports:
Check that the boom supports operate without binding.
- 4.6 Quick - Tach, Operation & Linkage:
Ensure the quick - tach linkage operates smoothly without binding and the safety locks engage the attachments completely.
- 4.7 Seat Belt:
Check seat belt condition. If necessary replace.
For your safety, the loader is equipped with electrically activated safety devices through the seat and seat belt. See Section 5.

5 Electrical

- 5.1 Battery:
Maintenance Free.

5.2 Battery Terminals:

Check battery terminals for corrosion. If necessary, clean.

5.3 Operation of Starter:

Engage and disengage the starter several times to ensure it's working properly. To prevent starter damage do not engage for more than 15 seconds. Allow 1 minute between starting attempts for cooling the starter.

5.4 Operation of Electrical Equipment:

Make a complete check of all electrical equipment, gauges, warning devices, pre-heat indicator, work lights, seat switch and belt and all optional equipment to ensure they are operating correctly.

6 Grease / Lubrication

Lubricate the following points with a good quality grease. Numbers marked () indicate the number of fittings at each location.

- Rear Boom Pivots (2)
- Boom Cylinder Bushings (4)
- Bucket Cylinder Bushings (4)
- Engine Universal Joint (2)
- Boom Supports (2)
- Quick - Tach Pivot and Lock Pin (4)
- Control lever pivot (2)
- Control cross shaft assembly (1)

7 General

7.1 Tire Pressure:

Check the tire pressure and if necessary inflate to the following pressures: 12.00 x 16.5 @ 45-50 psi (310-345 kPa), Flotation tires may be inflated to 50 psi (345 kPa) on hard flat surfaces.

7.2 Wheel Nut Torque:

Check and torque wheel nuts to 100 - 110 ft lbs (136 - 149 Nm).

7.3 Condition of Cab:

Inspect the condition of the ROPS mounting isolators. Replace isolators if deteriorated. Inspect both the seat and seat belt. Ensure all safety and instruction decals are in place. Inspect sound insulation, side windows and door operation for machines equipped with cab enclosure kits.

7.4 Condition of Shields and Safety Equipment:

Inspect and ensure all shields are in place and securely fastened. Inspect and ensure all safety equipment is working properly. Ensure owners and operators manual, safety manual and all safety and instruction decals are in place. If necessary, replace. If the safety controls are malfunctioning or require adjustment consult your **Thomas** Equipment Dealer for service.

7.5 General Condition:

Make a general inspection of the machine looking for loose or missing parts, oil leaks, etc.

TROUBLESHOOTING 8.2

8. 2A Hydrostatic Drive

Symptom	Cause	Remedy
No power on one side (both directions)	Reservoir low on oil	Replenish with 10W30 API SJ oil. Check for hose or fitting leak.
	Disconnected control linkage	Reconnect and adjust linkage.
	Groove pin sheared on pump pintle lever	Replace. Check pintle lever for loose bolt or excessive play.
	High pressure line failure	Replace line. Ensure new line fits without being forced. If necessary stress relieve.
	Drive chain failure	Replace chain and connection link.
	Motor shaft failure Check mounting bolts.	Inspect and repair defective parts. motor
	Excessive internal leakage in pump and/or motor	Inspect and repair defective unit. Flush all lines and tank. Replace filter. Check on type of fluid used and engine rpm.
No power on one side (one direction only)	Defective relief valve	Replace defective valve.
	Damaged ball check	Disassemble and repair.
No power on both sides (also loss of hydraulic power)	Reservoir low on oil	Replenish with 10W30 API SJ. Check for hose or fitting leaks
	Drive adaptor failure between engine and pump	Inspect and repair damaged parts Flush all lines and tank, change filter. Check on type of fluid used and engine rpm
	Damaged ball check	Disassemble and repair
Gradual loss of power as machine warms up	Excessive internal leakage in pump and/or motor	Consult dealer or Thomas Service Dept.

8.2A Hydrostatic Drive

Symptom	Cause	Remedy
System erratic and/or noisy	Air in system due to low oil level in reservoir	Replenish with 10W30 API SJ oil.
	Air in system due to leak at suction fitting	Check fittings and tighten.
	Internal pump or motor wear caused by overspeeding	Consult your dealer or Thomas Service Dept.
	Excessive play in linkage or pintle lever	Adjust linkage and tighten or replace pintle lever.
Machine will not travel in a straight line in high range	Control levers binding	Check that shields are not stopping lever from full travel.
		Check for linkage binding at spring mount. Adjust tracking.

8.2B Final Drive Transmission

Symptom	Cause	Remedy
Final drive transmission noisy	No lubricating oil	Check and bring oil to the proper level. Use 10W30 API SJ oil
	Parking brake damaged or out of adjustment	Inspect and adjust or replace damaged parts
	Axles have too much end play	Pre-load axle bearings removing all end play
	Chain loose	Replace the chain

8.2C Park Brake

Symptom	Cause	Remedy
Brake will not hold machine	Brake valve will not release pressure	Verify position of override
	Brake parts damaged or worn	Consult your Dealer or Thomas Service Dept.
	Brakes are disengaged	Engage parking brake
Brake will not release machine	No power to brake valve solenoid	Check fuse, If fine, consult Dealer or Thomas Service Dept.
	No pressure in supply line to brake valve	Consult your Dealer or Thomas service Dept.
	Brakes are engaged	Release brake

TROUBLESHOOTING 8.2

8.2D Hydraulic System

8.2D Hydraulic System

Symptom	Cause	Remedy
Hydraulic action jerky	Reservoir low on oil	Replenish with 10W30 API or 20W50 CF oil.
	Air in hydraulic system	Check for leak between reservoir and pump. Bleed system by extending and retracting lift cylinders several times.
	Anti-cavitation check valve not functioning	Inspect and repair or replace
Boom raises slowly at full engine rpm	Reservoir low on oil	Replenish with 10W30 or 20W50 API SJ oil
	Foot pedal linkage binding	Inspect and adjust
	Auxiliary hyd engaged	Disengage
	Engine rpm too slow	Check rpm and reset
	Anti-cavitation check valve spring broken	Replace
	Pressure relief valve in control valve faulty	Check pressure if necessary - adjust
	Internal leakage in pump due to wear	Check pump flow and repair or replace as necessary
	Oil bypassing one or both lift cylinder piston seals	Install new piston seal kits
Lift or tilt cylinders will not support a load	External leak between or at control valve and cylinders	Check for leaks and correct
	Control valve spool not centering	Check for sticking foot pedal linkage
		Check for broken or stuck return spring on valve spool
Oil leaking by one or both cylinder piston seals	Install new piston seal kits	
Hydraulic oil overheating	Reservoir low on fluid	Replenish with 10W30 or 20W50 API SJ oil
	Oil cooler plugged or dirty (also check engine radiator)	Clean cooling fins

Symptom	Cause	Remedy
Loss of hydraulic power (no flow from gear pump)	Reservoir low on fluid. Hose or fitting leak.	Replenish with 10W30 or 20W50 API SJ oil. Check for leaks.
	Drive adaptor between engine and pump failure	Inspect and replace damaged parts. Check for misalignment between engine and pumps.
	Spline coupling failure between front and rear hydrostatic pump	Inspect coupling for sheared splines. Also check pump shaft bearings.
	Hydraulic gear pump not functioning	Inspect and repair.
	Reservoir low on fluid	Replenish with 10W30 or 20W50 API SJ oil
Loss of hydraulic power (flow from gear pump)	Foot pedal linkage disconnected or binding	Inspect and adjust.
	Auxiliary engaged	Disengage
	Relief valve failure in control valve	Check pressure and adjust.
Hydraulic oil overheating	Auxiliary engaged	Disengage
	Engine rpm too slow	Check rpm and adjust
	Incorrect temperature sensor	Replace
Foot pedals do not operate smoothly	Foot pedal linkage out of adjustment	Adjust foot pedal linkages
	Foot pedal linkages need lubrication	Lubricate with a silicone based lubricant

TROUBLESHOOTING 8.2

8.2E Control Levers

Symptom	Cause	Remedy
Control levers will not center	Linkage out of adjustment	Adjust, check for wear at rod ends, loose counter nuts
	Linkage disconnected	Reconnect, check for wear at rod ends, loose counter nuts
	Centering spring broken	Replace
	Linkage binding	Control levers binding with safety shields or sound insulation Adjust control lever bearings binding in lever assy. Inspect replace or clean as required
Machine operates erratically	Control lever linkage loose	Inspect linkage for wear at rod ends, loose counter nuts
	Bolt in pintle lever loose or broken	Replace bolt. Ensure bolt clamping lever to pump shaft is tight
		See troubleshooting hydrostatic system
Machine loses power while turning		See troubleshooting hydrostatic system
Machine will not travel in straight line	Linkage binding	Adjust
	Control lever travel out of adjustment	Adjust
Control levers do not operate smoothly	Internal pump and / or motor leakage	See troubleshooting hydrostatic system
	Control lever linkage out of adjustment	Adjust control lever linkages
	Control lever linkages need lubrication	Lubricate

8.2F Electrical

Symptom	Cause	Remedy	
Engine will not crank over	Battery failure	Check battery, charge or replace	
	Battery cable failure	Check for loose or corroded connectors. Tighten and clean as required. Use dielectric grease to prevent corrosion. Check continuity of cables and replace if defective	
		Starter failure	Repair or replace
		Fuse burnt	Check and replace
		Defective relay	Check relay continuity if defective, replace
	Ignition switch failure	Check continuity and if defective, replace	
Engine cranks over, but will not start	Auxiliary hydraulics engaged	Engine will smoke but not run unassisted by starter. Disengage aux. hydraulics	
	Defective glow plug relay	Check continuity and if defective, replace	
	Defective glow plugs	Check continuity and if defective, replace	
	Broken connection or defective wire	Check continuity of the circuit not functioning properly in both engine and ROPS harness.	
	No fuel	Check fuel levels and system	
Loader starts, but hyd. controls will not release	Electro solenoid not releasing valve spools	Defective solenoid or binding solenoid lock. Check continuity of connectors and wire.	
Engine will not stop when the key is turned OFF	Defective ignition switch	Check and replace	
	Mechanical damage of the governor	Check and repair or replace	

TROUBLESHOOTING 8.2

8.2G Diesel Engine







Symptom	Cause	Remedy
Engine does not start	No fuel	Replenish fuel
	Air in the fuel	Vent air
	Water in the fuel	Change fuel and repair or replace fuel system
	Fuel pipe clogged	Clean
	Fuel filter clogged	Clean or change
	Excessively high viscosity of fuel or engine oil at low temperature	Use the specified fuel or engine oil
	Fuel with low octane number	Use the specified fuel
	Fuel leak due to loose injection pipe retaining nut	Tighten nut
	Incorrect injection timing	Adjust
	Fuel cam shaft worn	Replace
	Injection nozzle clogged	Clean
	Injection pump malfunctioning	Repair or replace
	Seizure of crankshaft, camshaft, piston, cylinder liner or bearing	Repair or replace
	Compression leak from cylinder	Replace head gasket, tighten cylinder head bolt, glow plug and nozzle holder
	Improper valve timing	Correct or replace timing gear
Piston ring and liner worn	Replace	
Excessive valve clearance	Adjust	
Starter does not run	Battery discharged	Charge
	Starter malfunctioning	Repair or replace
	Key switch malfunctioning	Repair or replace
	Wiring disconnected	Connect
Engine revolution is not smooth	Fuel filter clogged or dirty	Clean or change
	Air cleaner clogged	Clean or change
	Fuel leak due to loose injection pipe retaining nut	Tighten nut
	Injection pump malfunctioning	Repair or replace
	Incorrect nozzle opening pressure	Adjust
	Injection nozzle stuck or clogged	Repair or replace
	Fuel overflow pipe clogged	Clean
	Governor malfunctioning	Repair
Either white or blue exhaust smoke is observed	Excessive engine oil	Reduce to the specified level
	Low grade fuel used	Repair or replace
	Fuel filter clogged	Adjust
	Air cleaner clogged	Adjust top clearance
Either black or dark gray exhaust smoke is observed	Overload	Lessen the load
	Low grade fuel used	Use the specified fuel
	Fuel filter clogged	Clean or change
	Air cleaner clogged	Clean or change

TROUBLESHOOTING 8.2

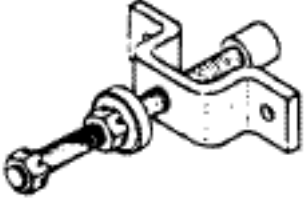

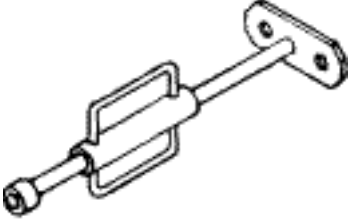



8.2G Diesel Engine

Symptom	Cause	Remedy
Excessive lubricant oil consumption	Piston rings gap facing the same direction	Shift gap direction
	Oil ring worn or stuck	Replace
	Piston ring groove worn	Replace
	Valve stem and guide worn	Replace
	Crankshaft bearing and crank pin bearing worn	Replace
Fuel mixed into lubricant oil	Injection pump plunger worn	Replace pump element or pump
	Injection pump broken	Replace
Water mixed into lubricant oil	Head gasket defective	Replace
	Cylinder block or cylinder head flawed	Replace
Low oil pressure	Engine oil insufficient	Replenish
	Oil strainer clogged	Clean
	Relief valve stuck with dirt	Clean
	Relief valve spring weakened or broken	Replace
	Excessive oil clearance of crankshaft bearing	Replace
	Excessive oil clearance of crank pin bearing	Replace
	Excessive oil clearance of rocker arm bearing	Replace
	Oil passage clogged	Clean
	Oil pump defective	Replace
	Different type of oil	Use the specified oil type
High oil pressure	Relief valve defective	Replace
	Engine oil insufficient	Replenish
Engine overheated	Fan belt broken or elongated	Change or adjust
	Cooling water insufficient	Replenish
	Radiator net and radiator fin clogged with dust	Clean
	Inside of radiator corroded	Clean or replace
	Cooling water flow route corroded	Clean or replace
	Radiator cap defective	Replace
	Overload running	Loosen the load
	Head gasket defective	Replace
	Incorrect injection timing	Adjust
Deficient output	Unsuitable fuel used	Use the specified fuel
	Incorrect injection timing	Adjust
	Engine's moving parts seem to be seizing	Repair or replace
	Uneven fuel injection	Repair or replace injection pump
	Deficient nozzle injection	Repair or replace nozzle
	Compression leak	Replace head gasket, tighten cylinder head bolt, glow plug and nozzle holder
Battery quickly discharges	Battery electrolyte insufficient	Replenish distilled water
	Fan belt slips	Adjust belt tension or change
	Wiring disconnected	Connect
	Rectifier defective	Replace
	Alternator defective	Replace
	Battery defective	Change







SPECIAL TOOLS 8.3

P / N	Illustration	Description	Model
955280		AXLE INSTALLATION TOOL - To install axle in final drive housing. Quantity - 1	T103 T135 T133'S'
955281		SEAL INSTALLATION TOOL - To install axle seal in final drive housing. Quantity - 3 required	T103 T135 T133'S'
955283 (6 bolt) 960475 (8 bolt)		AXLE EXTRACTOR TOOLS - To remove axle from final drive housing. Quantity - 1	T103 T135 T173HLS' T173HL'S'II T175/1700 T203HD T233HD T243HDS
955287		SEAL INSTALLATION TOOL - To install axle seal in final drive housing. Quantity - 1	T173 T233
957189		SEAL INSTALLATION TOOL - To install axle seal in final drive housing. Quantity - 2	T173HL T173HLS' T173HL'S'II T175/1700 T203HD T233HD T243HD'S
960997		CHAIN TENSION TOOL - To test chain tension.	T103 T135 T133'S'
	Universal Tool Kit	1 each. Combination wrench 7/16", 1/2", 9/16", 11/16" 3/4", 1 1/16", 1 1/4". Sockets, 1", 1/2" drive, 7/8", 1/2" drive, tool pouch, allen wrench 5/32" and 1/8"	ALL MODELS

SPECIAL TOOLS 8.3

P / N	Illustration	Description	Model
916-30042-01 25197		<p>DRY LINER PULLER - Used for removing and installing the dry liner of the engine.</p> <p>Consists of: 304742 (64mm); 304743 (68mm); 30744 (75mm) 304745 (76mm); 304746 (82mm); 304747 (105mm); Removing Plates; 304748 Installing Plate</p>	Kubota
07909-30202-01 25198		<p>DIESEL ENGINE COMPRESSION TESTER - Used to measure diesel engine compression and diagnosis of need for major overhaul.</p>	Kubota
07916-30820-01 25199		<p>CRANKSHAFT NUT SOCKET - Used to take off and fix the crankshaft nut. (46 mm).</p>	Kubota
07916-30840-01 25200		<p>NOZZLE REMOVER SOCKET- Used to unfasten the screw type nozzle holders.</p>	Kubota
70090-01125-01 25201		<p>NOZZLE DISASSEMBLY SOCKET - Used in place of a vice for disassembly and repair of nozzles.</p>	Kubota
960456		<p>HYDRAULIC FLOW AND PRESSURE GAUGE ASSEMBLY.</p>	All Loaders

SPECIAL TOOLS 8.3

P/N	Illustration	Description	Model
43979	 <p>C1840</p>	CHAIN PULLER	ALL MODELS
43980	 <p>C1841</p>	SPANNER WRENCH 2" - 4 3/4" To repair hydraulic cylinders	ALL MODELS
50451	 <p>C1841</p>	SPANNER WRENCH - 255 tilt cylinder	T255
43981	 <p>C1837</p>	PHOTO SENSOR / WHEEL SPEED TACHOMETER (Dual Function)	ALL MODELS
	 <p>C1839</p>	FORCE GAUGE, PUSH PULL For measuring restraint bar brake cable adjustment. Special order only	T173HLS T173HLS II T243HDS T245HDS
	 <p>C2342</p>	MULTI METER For measuring continuity, voltage, etc.	ALL MODELS
	 <p>C2343</p>	ANGLE FINDER For measuring control angles, U-joint and chassis angles etc.	ALL MODELS

SPECIAL TOOLS 8.3

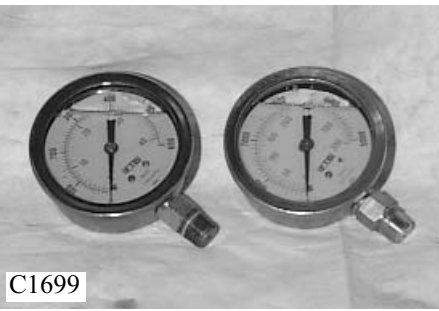
P/N	Illustration	Description	Model
44365	 C1699	METER, HYDRAULIC PRESSURE TEST KIT (WITH CASE) M35 ~ M46	ALL MODELS

NOTES



SPECIFICATIONS 8.4

LOADER SPECIFICATIONS

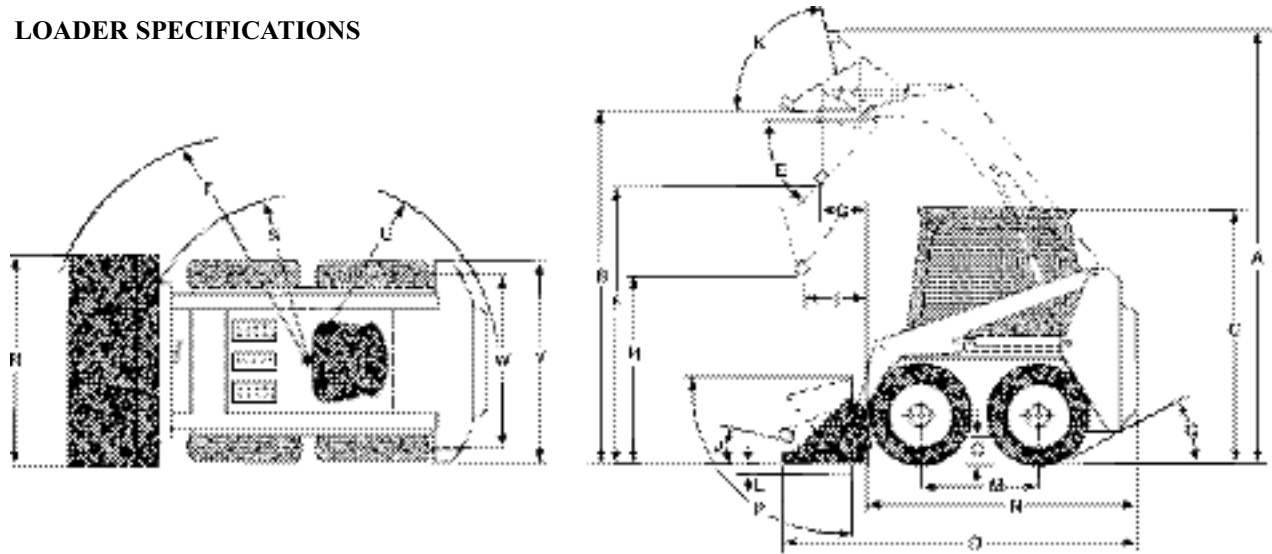

C-294

Dimensions

A. Overall operating height	157" (4267mm)
B. Height to hinge pin	123.8" (3385)
C. Overall vehicle height	84" (2108)
D. Overall length with bucket	146" (3538)
E. Dump angle	36°
F. Dump height	96.8" (2813)
G. Reach — fully raised	21.5" (540)
H. Height at 45° dump angle	80.3" (1918)
I. Reach at 45° dump angle	25.3" (749)
J. Maximum roll back at ground	20°
K. Maximum roll back fully raised	87°
M. Wheel base	48.75" (1003)
N. Overall length less bucket	117.5" (2800)
O. Ground clearance	9" (222)
P. Maximum grading angle — bucket	88°
Q. Angle of departure	27°
R. Bucket width	73" (1746)
S. Clearance circle — front — less bucket	54.2" (1295)
T. Clearance circle — front — with bucket	84" (2095)
U. Clearance circle — rear	69.8" (1664)
V. Overall width — less bucket	70.8" (1727)
W. Tread	58.5" (1403)

SPECIFICATIONS 8.4

Engine

Make and model	Kubota V3300T
Type.....	Vertical , In Line, 4 Cycle
Number of cylinders	4
Cylinder bore	98 mm (3.86 inches)
Stroke	110 mm (4.33 inches)
Displacement	202.53 cu. in.(3318 cm ³)
Maximum engine speed (no load)	2750 RPM
Low idle setting.....	1300 RPM
Cooling system	Liquid
Horsepower (Gross)	87.4 @ 2750 RPM
Power (ISO 9249 Net Power)	61.9 kW @ 2750 RPM
Max Torque	205 ft / lbs. (280 N m) @ 1400 RPM
Compression ratio.....	21.8: 1
Firing order (viewed from gear case end)	1 - 3 - 4 - 2
Fuel injection timing	16° BTDC.
Injector working pressure	137.2 bar (1991 psi.)
Direction of rotation (viewed from flywheel end)	Counter - clockwise
Location of timing marks	N / A
Valve clearance, (cold).....	0.0091 - 0.011 in (0.23 - 0.27 mm)
Fuel type	Diesel No. 2
Air cleaner	Replaceable dry cartridge w/indicator
Engine oil capacity with filter.....	13.2 litre (14 qts.)
Oil type.....	5W40API CF
Cooling system capacity	16 liter (4.2 gal.)
Radiator cap pressure setting.....	12. 8 PSI (98.1 kPa)
Thermostat rating	Fully open 194°F (90°C)

Hydraulic System

Pump type	Gear.	
Pump Capacity (theoretical @ 2750 RPM)	21.0 GPM (79.5 l/m)	
Pump Capacity (theoretical @ 2500 RPM)	19.2 GPM (72.7 l/m)	
System Relief Setting.....	3000 PSI (206.8 bar)	
Control valve	Series type with float on lift and electric auxiliary	
Filtration	5 Micron	
Hydraulic fluid	10W30 API Class, SJ	
Oil cooler	1250 BTU/min. (315 kJ)	
Cylinders.	Lift	Tilt.....
Type.....	Double acting	Double acting
Qty per loader	2	2.....
Bore diameter	3 in.	3 in.
Rod diameter	2 in.	2 in.
Stroke	27.9 in.	15.5 in.

SPECIFICATIONS 8.4

Hydrostatic Transmission & Final Drive

Pump type	Two in line, axial piston pumps
Pump displacement	2.80 cu. in. (46 cm ³)
Motor type	Radial Piston
Motor displacement (250).....	41.5 in ³ . (680 cm ³)
(255 Low Speed)	45.8 in ³ . (750 cm ³)
(255 High Speed).....	24.9 in ³ . (408 cm ³)
System relief setting	5000 PSI (345 bar)
Final drive	(2 of) Single roller chain running in oil bath to each axle
Drive chain size	ASA 100H

Electrical

Alternator	60 amp
Battery	2 x 12V
Cranking Amps	730 each (1460)
Starter	12 V (2.5 kW)
Circuit breaker rating	40 amp

Tires

Standard	12.00 x 16.5, 8 ply rating, 45 ~ 50 psi (310 ~ 345 kPa)
Optional	12.00 x 16.5, 10 ply rating, 45 ~ 50 psi (310 ~ 345 kPa)

Fluid Capacities

Fuel tank	28.7 gal. (109 L)	Diesel No. 2
Engine lubrication	14 qt. (13.2 L)	5W40 API CF
Final drive transmissions (each)	4.5 gal. (17 L)	10W30 API SJ
Hydraulic reservoir	35 gal. (133 L)	10W30 API SJ
Engine cooling system	4.2 gal. (16 L)	50 / 50 water & ethylene

SOUND POWER LEVEL

LWA Adjusted sound level at 10m (32.8ft). 105 DbA



SPECIFICATIONS 8.4

Torque Specifications

Loader

Wheel nuts (24) 100 - 110 ft lbs. (136 - 139 Nm)
 Motor mount isolators (4) 80 ft / lbs (109 Nm)

FOR NON-CRITICAL AND NOT OTHERWISE MENTIONED APPLICATIONS. THE FOLLOWING GENERAL ASSEMBLY TORQUES WILL APPLY:

Bolts & Nuts Torque ft. lbs (Nm.)

1/4 - 20	5 - 7 (6.7 - 9.5)	7/16 - 20	40 - 45 (54 - 61)
5/16 - 18	12 - 15 (16 - 20)	1/2 - 13	45 - 50 (61 - 68)
5/16 - 24	12 - 15 (16 - 20)	1/2 - 20	50 - 60 (68 - 81)
3/8 - 16	17 - 22 (23 - 30)	9/16 - 12	60 - 70 (81 - 95)
3/8 - 24	22 - 27 (30 - 37)	9/16 - 18	65 - 75 (88 - 102)
7/16 - 14	30 - 35 (41 - 47)	5/8 - 11	75 - 85 (102 - 115)
		5/8 - 18	100 - 110 (136 - 150)

Hydraulic Fittings: Specifications listed in ft / lbs. Multiply by 1.36 for Nm.

HOSE SIZE	37° JIC FITTINGS	HOSE SIZE	ORB FITTINGS
1/4	9 to 10	1/4	14 to 16
5/16	15 to 16	5/16	18 to 20
3/8	20 to 22	3/8	24 to 26
1/2	30 to 33	1/2	50 to 60
5/8	40 to 44	5/8	72 to 80
3/4	70 to 77	3/4	125 to 135
7/8	82 to 90	7/8	160 to 180
1	55 to 60	1	200 to 220
1 1/4	120 to 132	1 1/4	210 to 280
1 1/2	131 to 144	1 1/2	270 to 360
2	300 to 330		

The following torque specifications are for steel ORB fittings into aluminum.

HOSE SIZE	ORB FITTINGS	HOSE SIZE	ORB FITTINGS
1/4	5 to 7	3/4	40 to 45
5/16	8 to 10	7/8	50 to 55
3/8	10 to 12	1	90 to 99
1/2	21 to 24	1 1/4	80 to 90
5/8	27 to 30		

Tandem Pump

Description	Qty.	Specification
Bottom Support	2	80 (+/- 2)
Rear Mounting	2	80 (+/- 2)
Trunion Seal Carrier	4	20 (+/- 2)
Trunion Seal Cover	4	20 (+/- 2)
Relief Valve	4	40 (+/- 10)
Charge Relief Cap	1	40 ~ 100
Tandem Section	4	40 (+/- 5)
Gear Pump	2	51 ~ 62

8

DECALS 8.5

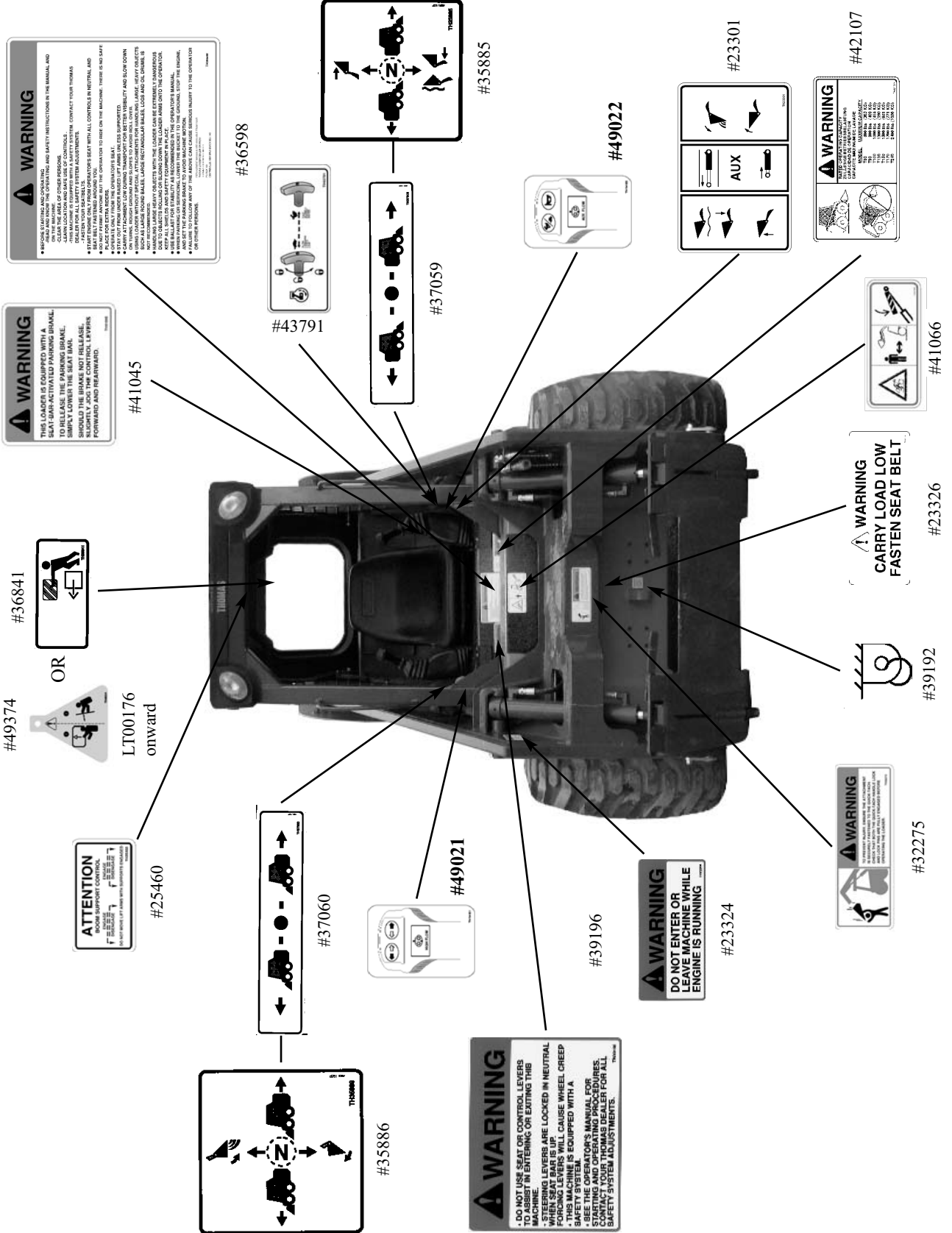

DECALS 8.5



#49020

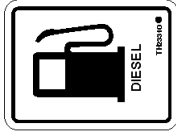

#23310



#46301

THOMAS
#44615

OIL. 5W40 API CF
#42110



#23325



#39191

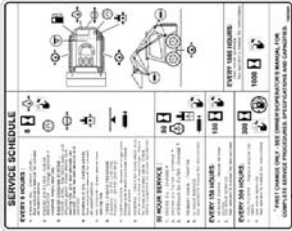

#23321



#37010

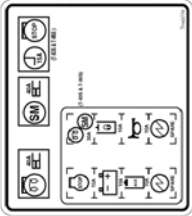

#43776



#49020

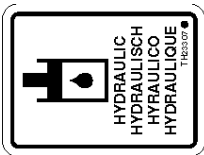

#23307

OIL. 10W30 API SE. C16
#38043



#23312

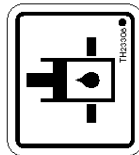

#23308



#49019



#39192

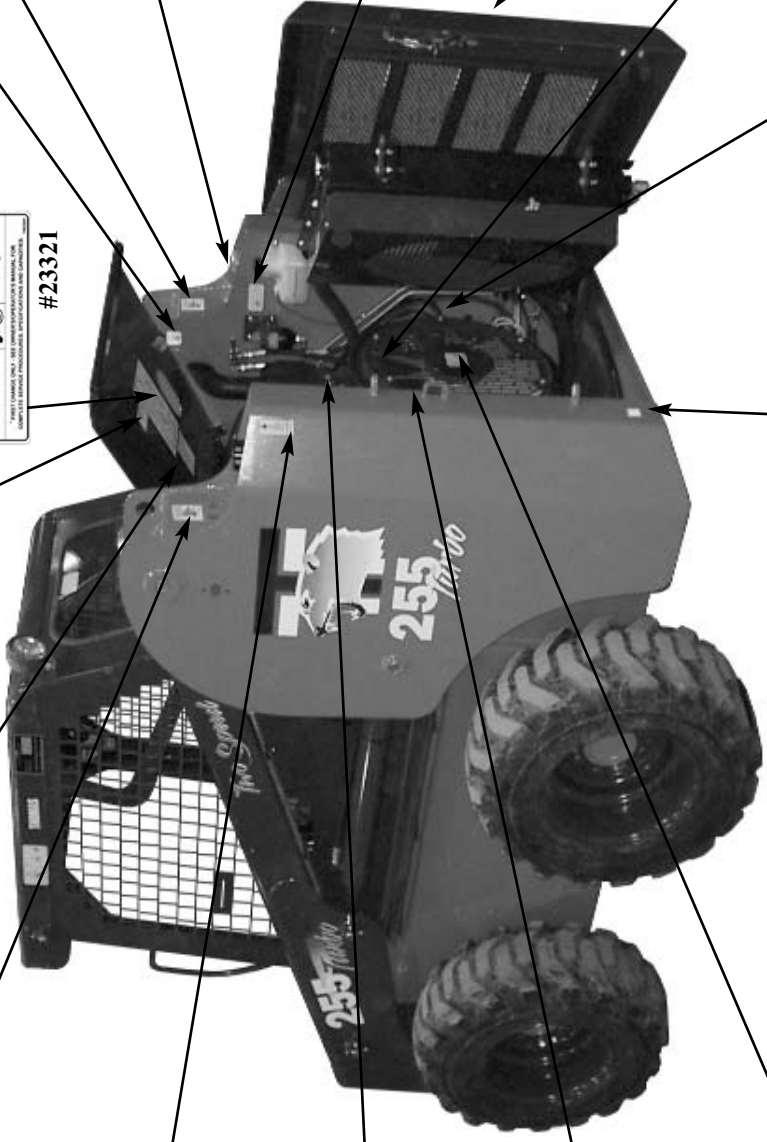

DECALS 8.5

THOMAS
#44615

Two Speed

#49023 (Not available on all models)

#49018 (255 Kit)
#49438 (250 Kit)

- # 49273 Common Decal kit
- # 49190 Decal kit, Portuguese
- # 49191 Decal kit, French
- # 49192 Decal kit, German
- # 49193 Decal kit, Italian
- # 49194 Decal kit, Spanish
- # 49195 Decal kit, Dutch
- # 49196 Decal kit, Danish



#41065

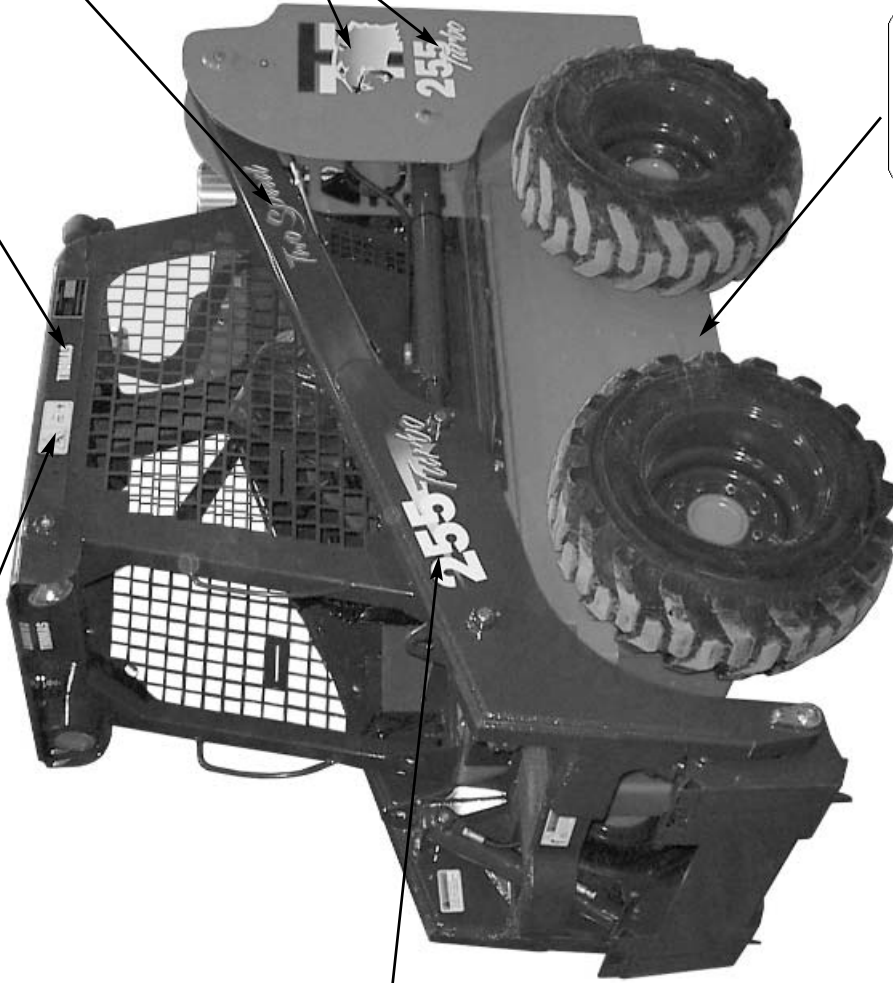

#49018 (255 Kit)
#49438 (250 Kit)

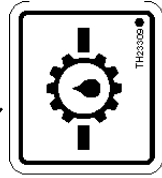

#23309

- # 49656 Tag, ROPS/FOPS Approval
- # 43145 Decal, Park Brake
- # 47858 Decal, LWA 105 Noise Output (CE Only)

NOTES

